

Skillair® PADLOCKABLE REGULATOR

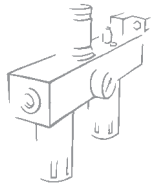

The padlockable regulator has a pin with a hole in it that projects from the top of the knob. When the knob is in the push-lock position, the padlock can be inserted in the hole, preventing the knob from being operated. A padlock and two keys are supplied with the regulator.

The new Skillair regulator uses a rolling diaphragm which gives a much better performance than the flat version.

Advantages of this system:

- Increased stroke, increased valve opening and hence higher flow rate.
- Decreased dynamic and inrush friction; prompter, more sensitive operation.
- Reduced working stress and hence longer life allowing the use of thinner diaphragms (0.45 mm versus 1.5 mm for a flat one) which increases regulator sensitivity and prompt action.
- Increased accuracy in maintaining the set pressure with both variable flow rates and different feed pressures.
- Downstream overpressures relieved quickly.



TECHNICAL DATA	REG 100 KEY	REG 100 KEY	REG 200 KEY	REG 200 KEY	REG 200 KEY	REG 300 KEY	REG 300 KEY	REG 300 KEY
Threaded port	G 1/4"	G 3/8"	G 1/4"	G 3/8"	G 1/2"	G 1/2"	G 3/4"	G 1"
Setting range	0÷2 - 0÷4 - 0÷8 - 0÷12		0÷2 - 0÷4 - 0÷8 - 0÷12			0÷2 - 0÷4 - 0÷8 - 0÷12		
Max. input pressure	bar	1.5	bar	1.3	bar	1.3	bar	1.3
	MPa	0.21	MPa	0.19	MPa	0.19	MPa	0.19
	psi	217	psi	188	psi	188	psi	188
Flow rate at 6.3 bar (0.63 MPa-91 psi)	NI/min	1100	NI/min	2500	NI/min	3500	NI/min	3500
ΔP 0.5 bar (0.05 MPa - 7 psi)	scfm	39	scfm	88	scfm	124	scfm	124
Flow rate at 6.3 bar (0.63 MPa-91 psi)	NI/min	1600	NI/min	3500	NI/min	7000	NI/min	7000
ΔP 1 bar (0.1 MPa - 14 psi)	scfm	57	scfm	124	scfm	247	scfm	247
Fluid	Filtered lubricated or unlubricated compressed air. Lubrication, if used, must be continuous.							
Max temperature at 1 MPa; 10 bar; 145 psi	°C	50	°C	50	°C	50	°C	50
	°F	122	°F	122	°F	122	°F	122
Weight	Kg	0.4	Kg	0.7	Kg	1.4	Kg	1.4
Wall fixing screws		M4x50		M5x60		M5x70		M5x70
Mounting	In any position							
Pressure gauge port	G 1/8"							
Notes on use	The regulator pressure must always be set upwards. For increased sensitivity, use a pressure regulator with a rated pressure as close as possible to the required value. Do not take air from pressure gauge ports.							

COMPONENTS

- ① Technopolymer body
- ② Zamak end plate
- ③ Technopolymer knob
- ④ Technopolymer bell
- ⑤ Nickel-plated brass OT58 adjusting screw
- ⑥ OT58 brass scroll
- ⑦ Steel adjusting spring
- ⑧ Technopolymer ring nut
- ⑨ Rolling diaphragm
- ⑩ NBR relieving gaskets
- ⑪ OT58 brass stem
- ⑫ Valve with NBR vulcanized gasket
- ⑬ Stainless steel valve spring
- ⑭ Technopolymer plug
- ⑮ NBR gaskets
- ⑯ Padlock

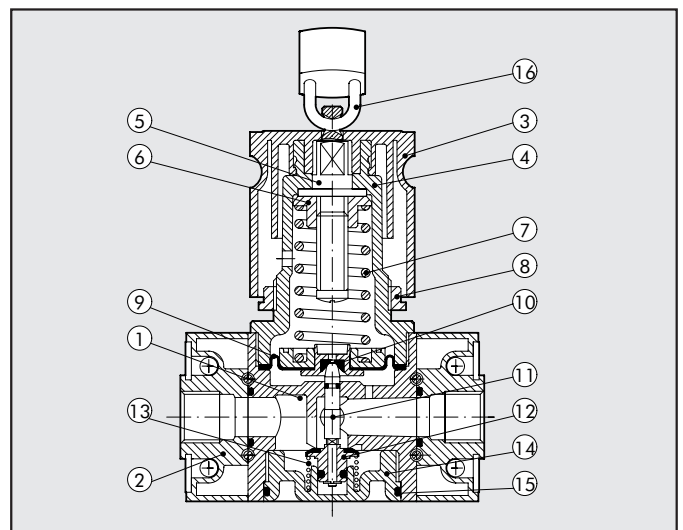

FLOW CHARTS

REG 100 1/4 - 3/8

Preset pressure
Pm = 7 bar - 0,7 MPa - 100 psi

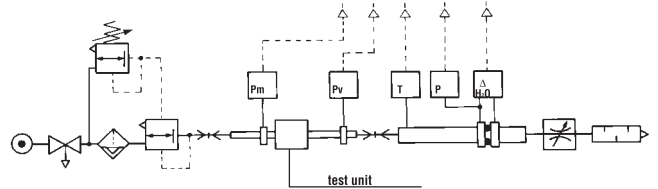
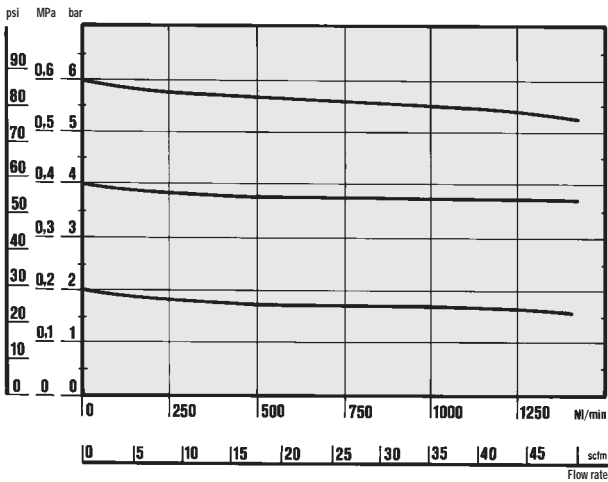

• Flow tests carried out at the Department of Mechanics, Turin Polytechnic, using the computerized test bench following CETOP RP50R recommendations (ISO DIS 6358-2-approved) with ISO 5167 diaphragm gauge.

REG 200 1/4 - 3/8 - 1/2

Preset pressure
Pm = 7 bar - 0,7 MPa - 100 psi

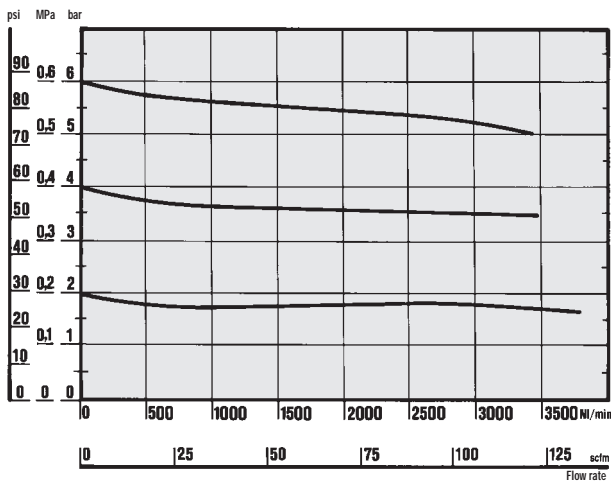

REG 300 1/2 - 3/4 - 1

Preset pressure
Pm = 7 bar - 0,7 MPa - 100 psi

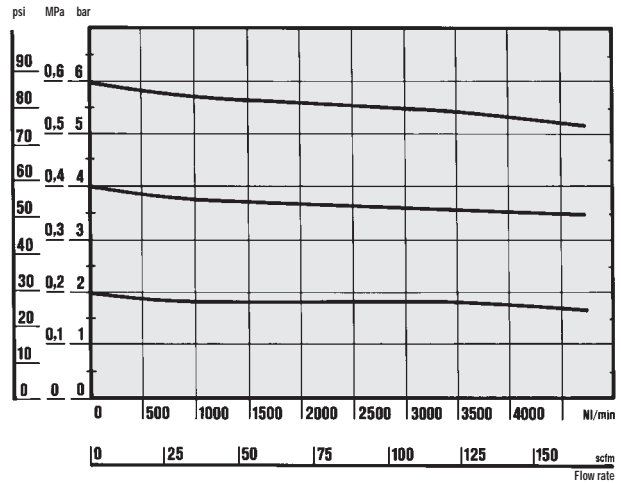

DIMENSIONS

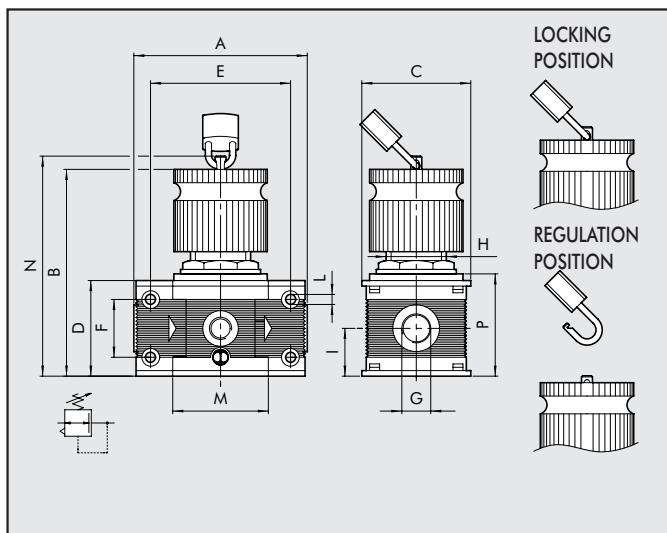

	REG 100 KEY	REG 100 KEY	REG 200 KEY	REG 200 KEY	REG 200 KEY	REG 300 KEY	REG 300 KEY	REG 300 KEY
	G 1/4	G 3/8	G 1/4	G 3/8	G 1/2	G 1/2	G 3/4	G 1"
A	78			93.5			110	112
B	95 ÷ 98			123 ÷ 125			145 ÷ 148	
C	50			63			72	
D	43			55			65	
E	63			78.5			92	
F	26			36			42	
G	G 1/4	G 3/8	G 1/4	G 3/8	G 1/2	G 1/2	G 3/4	G 1"
H	30x1.5			40x1.5			48x1.5	
I	21.5			27.5			32.5	
L	M4 hole			M5 hole			M5 hole	
M	43			55.5			65	
N	101			127			151	
P	46			58			69	

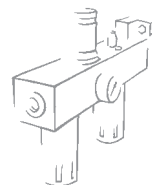

KEY TO CODES

REG ELEMENT	100 SIZE	KEY TYPE	1/4 THREADED PORT	02 SETTING RANGE
REG = REGULATOR	100	KEY = PADLOCKABLE	1/4	02 = 0 ÷ 2 bar
	200		3/8	04 = 0 ÷ 4 bar
	300		1/4	08 = 0 ÷ 8 bar
			3/8	012 = 0 ÷ 12 bar
			1/2	
			1/2	
			3/4	
			1	

ORDERING CODES

SKILLAIR 100 PADLOCKABLE REGULATOR

Code	Description
3210001A	REG 100 KEY 02 WITHOUT END PLATES
3210002A	REG 100 KEY 04 WITHOUT END PLATES
3210003A	REG 100 KEY 08 WITHOUT END PLATES
3210004A	REG 100 KEY 012 WITHOUT END PLATES
3210001	REG 100 KEY 1/4 02
3210002	REG 100 KEY 1/4 04
3210003	REG 100 KEY 1/4 08
3210004	REG 100 KEY 1/4 012
3310001	REG 100 KEY 3/8 02
3310002	REG 100 KEY 3/8 04
3310003	REG 100 KEY 3/8 08
3310004	REG 100 KEY 3/8 012

SKILLAIR 200 PADLOCKABLE REGULATOR

Code	Description
3410001A	REG 200 KEY 02 WITHOUT END PLATES
3410002A	REG 200 KEY 04 WITHOUT END PLATES
3410003A	REG 200 KEY 08 WITHOUT END PLATES
3410004A	REG 200 KEY 012 WITHOUT END PLATES
3410001	REG 200 KEY 1/4 02
3410002	REG 200 KEY 1/4 04
3410003	REG 200 KEY 1/4 08
3410004	REG 200 KEY 1/4 012
3510001	REG 200 KEY 3/8 02
3510002	REG 200 KEY 3/8 04
3510003	REG 200 KEY 3/8 08
3510004	REG 200 KEY 3/8 012
3610001	REG 200 KEY 1/2 02
3610002	REG 200 KEY 1/2 04
3610003	REG 200 KEY 1/2 08
3610004	REG 200 KEY 1/2 012

SKILLAIR 300 PADLOCKABLE REGULATOR

Code	Description
4410000A	REG 300 KEY 02 WITHOUT END PLATES
4410001A	REG 300 KEY 04 WITHOUT END PLATES
4410002A	REG 300 KEY 08 WITHOUT END PLATES
4410003A	REG 300 KEY 012 WITHOUT END PLATES
4410000	REG 300 KEY 1/2 02
4410001	REG 300 KEY 1/2 04
4410002	REG 300 KEY 1/2 08
4410003	REG 300 KEY 1/2 012
4510000	REG 300 KEY 3/4 02
4510001	REG 300 KEY 3/4 04
4510002	REG 300 KEY 3/4 08
4510003	REG 300 KEY 3/4 012
4610000	REG 300 KEY 1 02
4610001	REG 300 KEY 1 04
4610002	REG 300 KEY 1 08
4610003	REG 300 KEY 1 012

NOTES

Blank area for notes.

Skillair® PILOT PADLOCKABLE REGULATOR

The pilot regulator is used when great accuracy is required in maintaining the set pressure under changing operating conditions.

It is ideal for use as:

- a precision regulator for flow rates < 100 NI/min.
- a pilot in general – typically for large size regulators (see REG 400).

The system's high operating accuracy and low hysteresis are determined by the virtually total lack of friction. The presence of a slight air leak is necessary for the regulator to operate properly – it is not a malfunction.

It is advisable to use filtered air.

The pilot padlockable regulator has a pin with a hole in it that projects from the top of the knob. When the knob is in the push-lock position, the padlock can be inserted in the hole, preventing the knob from being operated. A padlock and two keys are supplied with the regulator.



TECHNICAL DATA		PILOT PADLOCKABLE REGULATOR	
Threaded port		G 1/4"	
Setting range	bar	0÷2 - 0÷4 - 0÷8 - 0÷12	
Max. input pressure	MPa	1.3	
	bar	13	
	psi	188	
Flow rate at 6.3 bar (0.63 MPa-91 psi) ΔP 0.5 bar (0.05 MPa – 7 psi)		120 NI/min - 4,3 scfm	
Flow rate at 6.3 bar (0.63 MPa-91 psi) ΔP 1 bar (0.1 MPa – 14 psi)		140 NI/min - 5 scfm	
Fluid		Filtered, lubricated or unlubricated compressed air. Lubrication, if used, must be continuous.	
Max temperature at 1 MPa; 10 bar; 145 psi	°C	50	
	°F	122	
Weight	Kg	0.6	
Mounting		In any position	
Pressure gauge port		G 1/8"	
Notes on use		The regulator pressure must always be set upwards. For increased sensitivity, use a pressure regulator with a rated pressure as close as possible to the required value. Do not take air from the pressure gauge ports. Mount directly on REG 400.	

COMPONENTS

- ① Aluminium body
- ② Technopolymer knob
- ③ Nickel-plated brass OT58 adjusting screw
- ④ OT58 brass scroll
- ⑤ Technopolymer bell
- ⑥ Technopolymer ring nut
- ⑦ Steel adjusting spring
- ⑧ Rolling diaphragm
- ⑨ NBR relieving gaskets
- ⑩ OT58 brass stem
- ⑪ Stainless steel ball valve
- ⑫ Stainless steel valve spring
- ⑬ NBR gaskets
- ⑭ Padlock

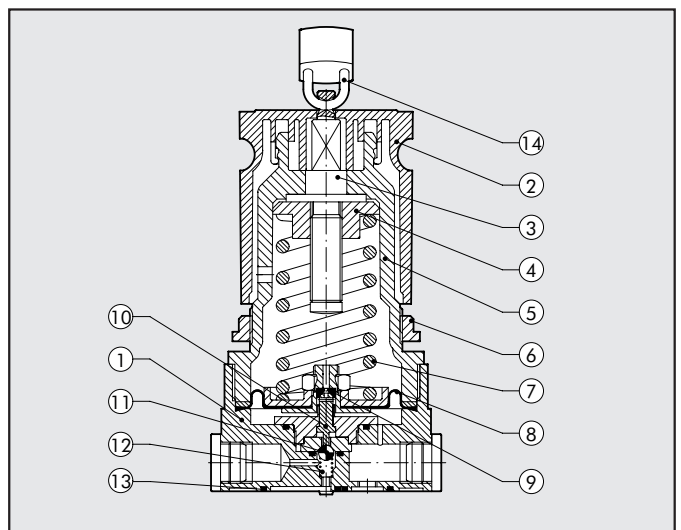

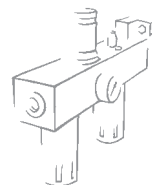

FLOW CHARTS

FLOW FEATURES REG. P 1/4''

Preset pressure
Pm = 7 bar - 0,7 MPa - 100 psi

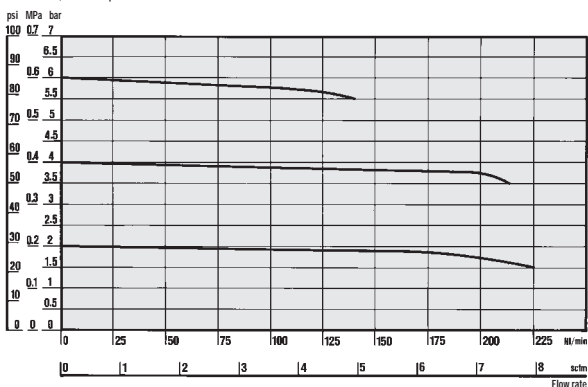

REGULATION FEATURES REG. P 1/4'' *

Flow: A = 0 Nl/min = 0 scfm
B = 25 Nl/min = 0,88 scfm - C = 50 Nl/min = 1,76 scfm

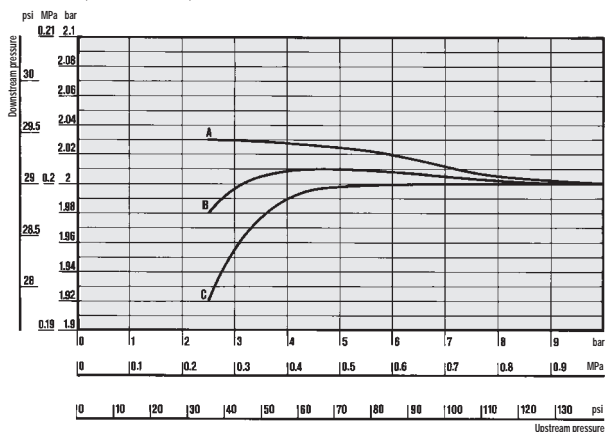

REGULATION FEATURES REG. P 1/4'' *

Flow: A = 0 Nl/min n = 0 scfm
B = 25 Nl/min = 0,88 scfm - C = 50 Nl/min = 1,76 scfm

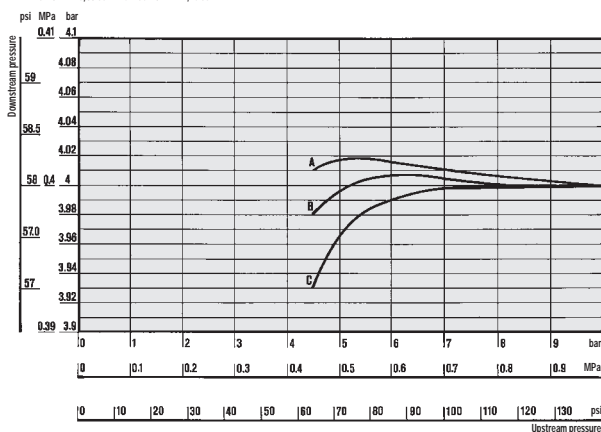

REGULATION FEATURES REG. P 1/4'' *

Flow: A = 0 Nl/min n = 0 scfm
B = 25 Nl/min = 0,88 scfm - C = 50 Nl/min = 1,76 scfm

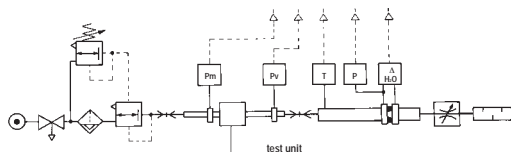
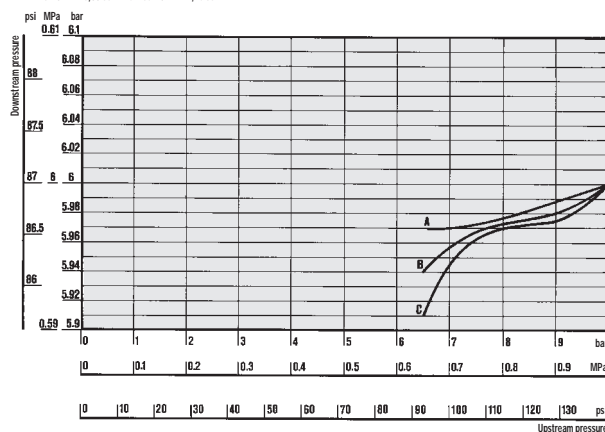

• Flow tests carried out at the Department of Mechanics, Turin Polytechnic, using the computerized test bench following CETOP RP50R recommendations (ISO DIS 6358-2-approved) with ISO 5167 diaphragm gauge.

* Pressure stability adjusted according to changes in upstream pressure.

DIMENSIONS

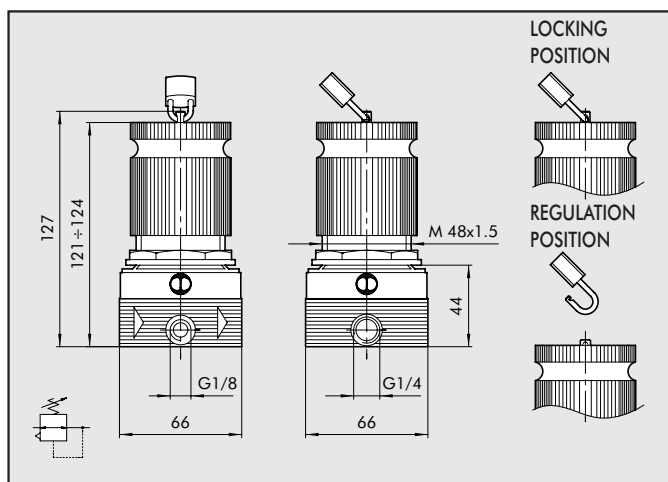

ORDERING CODES

Code	Description
3208001	REG. P KEY 1/4'' 02
3208002	REG. P KEY 1/4'' 04
3208003	REG. P KEY 1/4'' 08
3208004	REG. P KEY 1/4'' 012

Skillair® ACCESSORIES

MOUNTING BRACKET FOR REG.

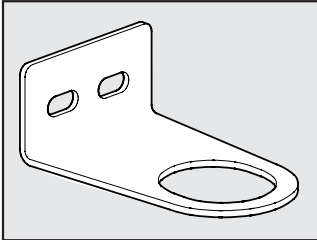

Code	Description
9200701	SF100- BIT-ND1/4
9400701	SF200-ND-3/8 1/2
9400702	SF300

CONNECTOR KIT FOR SKILLAIR CODE A

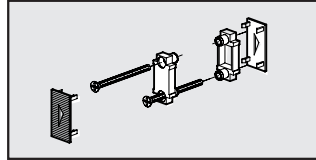

Code	Description
9230301	ACC. CONNECTOR KIT 100
9330301	ACC. CONNECTOR KIT 200
9430301	ACC. CONNECTOR KIT 300

PRESSURE GAUGES

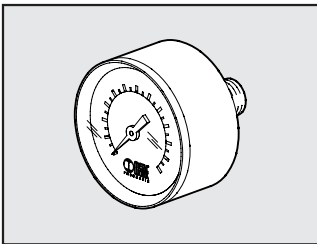

Code	Description
9700101	ACC. M 40 1/8 12
9700102	ACC. M 40 1/8 04
9800101	ACC. M 50 1/8 12
9800102	ACC. M 50 1/8 04

INPUT/OUTPUT END PLATE KIT

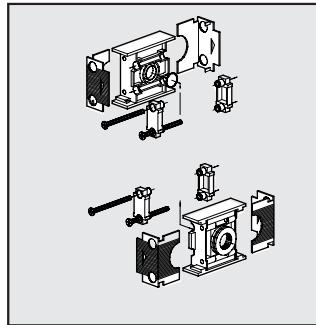

Code	Description
9230401	ACC. IN/OUT END PLATE KIT 100 1/4
9330501	ACC. IN/OUT END PLATE KIT 100 3/8
9330601	ACC. IN/OUT END PLATE KIT 200 1/4
9330701	ACC. IN/OUT END PLATE KIT 200 3/8
9330801	ACC. IN/OUT END PLATE KIT 200 1/2
9430701	ACC. IN/OUT END PLATE KIT 300 1/2
9530901	ACC. IN/OUT END PLATE KIT 300 3/4
9531001	ACC. IN/OUT END PLATE KIT 300 1"

REG VISUAL DOME DISASSEMBLY SPANNER

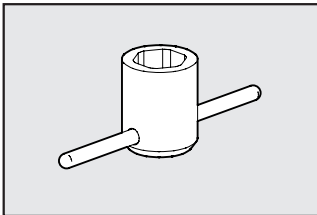

Code	Description
9220401	SPARES DOME DIS. SPANNER 100
9323401	SPARES DOME DIS. SPANNER 200
9420401	SPARES DOME DIS. SPANNER 300

POPPET DISASSEMBLY SPANNER (FOR REG.)

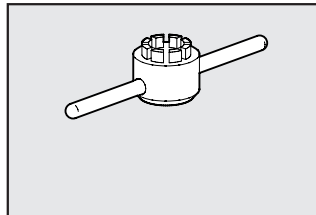

Code	Description
9220501	SPARES R CAP DISASS. WR. 100
9323501	SPARES R CAP DISASS. WR. 200
9420501	SPARES R CAP DISASS. WR. 300

Skillair® SPARE PARTS

COMPLETE POPPET FOR REGULATORS

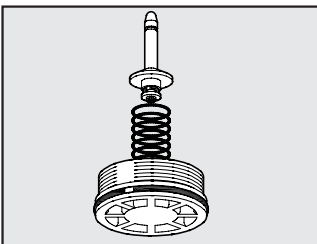

Code	Description
9250704	SPARES OTR 100
9350704	SPARES OTR 200
9450704	SPARES OTR 300

INPUT/OUTPUT COVER PLATE

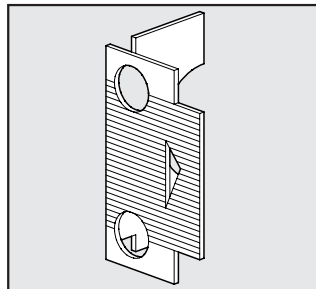

Code	Description
9152103	SPARES OUTPUT COVER PLATE 100
9152105	SPARES INPUT COVER PLATE 100
9152115	SPARES OUTPUT COVER PLATE 200
9152116	SPARES INPUT COVER PLATE 200
9152104	SPARES OUTPUT COVER PLATE 300
9152106	SPARES INPUT COVER PLATE 300

SPRINGS FOR REGULATORS

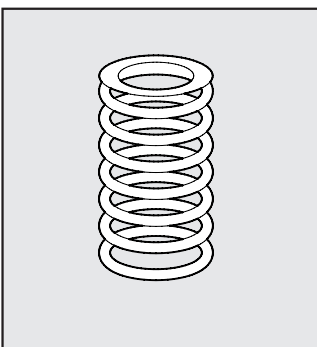

Code	Description
9250605	RIC.MO 100 02
9250606	RIC.MO 100 04
9250607	RIC.MO 100 08
9250608	RIC.MO 100 012
9350605	RIC.MO 200 02
9350606	RIC.MO 200 04
9350607	RIC.MO 200 08
9350608	RIC.MO 200 012
9450605	RIC.MO 300 04
9450606	RIC.MO 300 08
9450607	RIC.MO 300 012
9450608	RIC.MO 300 02

INTERMEDIATE COVER PLATE

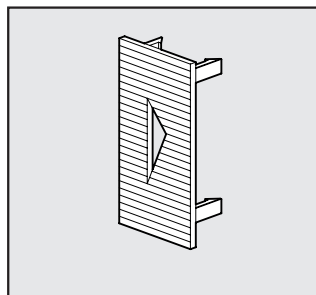

Code	Description
9152107	SPARES INTERM. COVER PLATE 100
9152114	SPARES INTERM. COVER PLATE 200
9152108	SPARES INTERM. COVER PLATE 300