

FIL+REG+LUB Skillair® 100-200-300

TECHNICAL DATA	FRL 100	FRL 200	FRL 300
Threaded port	1/4" 3/8"	1/4" 3/8" 1/2"	1/2" 3/4" 1"
Setting range	0 to 8 0 to 12	0 to 8 0 to 12	0 to 8 0 to 12
Degree of filtration	5µm 20µm		
Max. inlet pressure	MPa 1.5 bar 15 psi 217	1.3 13 188	1.3 13 188
Flow rate at 6.3 bar	Nl/min 300	1300	2500
ΔP 0.5 bar	scfm 11	46	89
Flow rate at 6.3 bar	Nl/min 800	3000	4500
ΔP 1 bar	scfm 28	106	160
Fluid	Compressed air		
Max temperature at 10 bar	°C 50 °F 122	50 122	50 122
Weight	Kg 0.75	1.5	2.9
Wall fixing screws	M4x50	M5x60	M5x70
Note on use	The maximum inlet pressure for the version with RA automatic condensate drainage must not exceed 10 bar.		

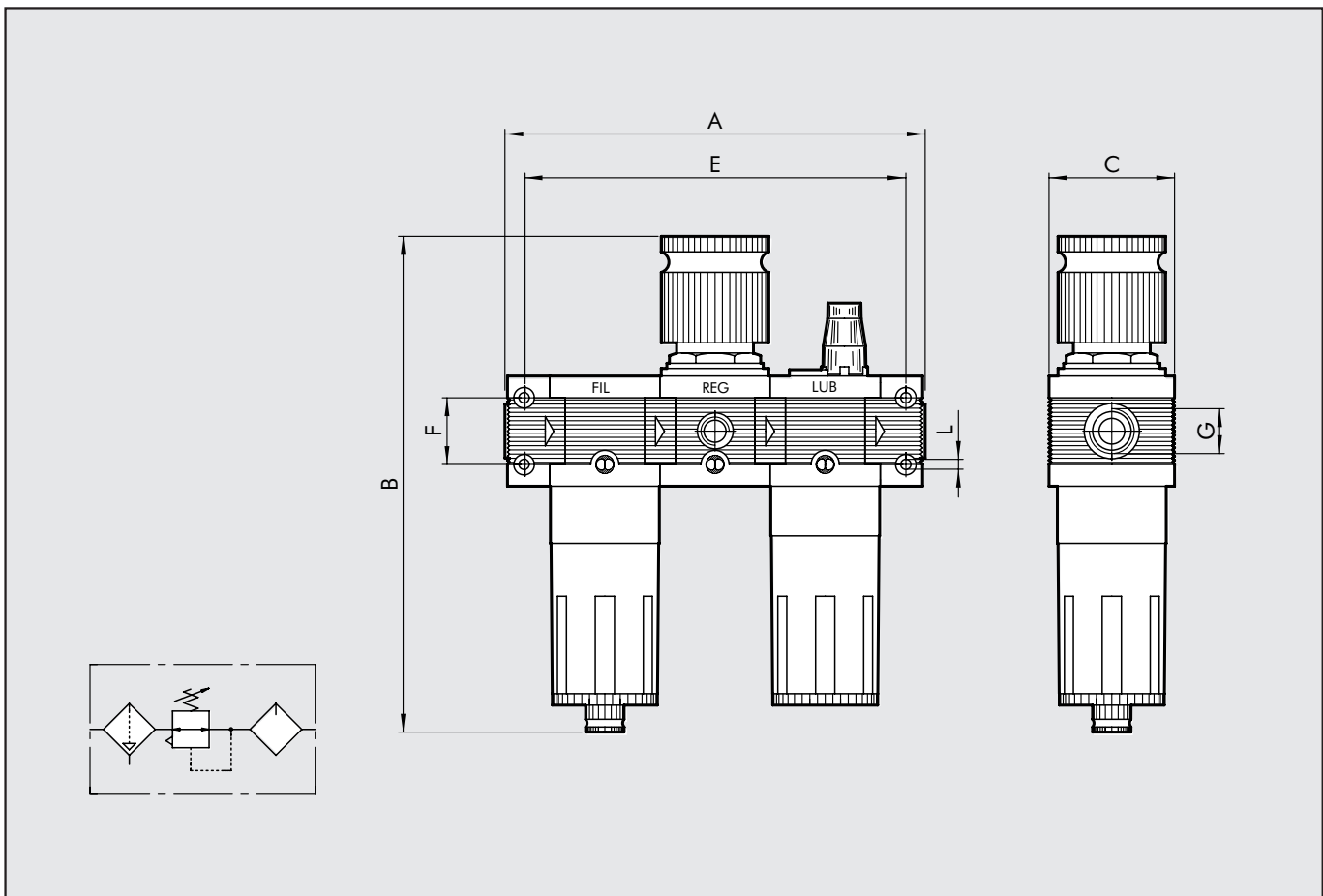

DIMENSIONS	FIL+REG+LUB 100		FIL+REG+LUB 200			FIL+REG+LUB 300		
THREADED PORT G	G 1/4	G 3/8	G 1/4	G 3/8	G 1/2	G 1/2	G 3/4	G 1"
A	164		204.5			240		242
B	199		245			278		
C	50		63			72		
E	149		189.5			222		
F	26		36			42		
L	M4 hole		M5 hole			M5 hole		



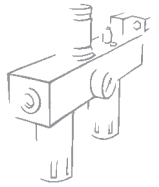

FIL+REG+LUB Skillair® 400

TECHNICAL DATA		FRL 400			
Threaded port		G1"	G1"1/4"	G1"1/2"	G2"
Setting range		Depending on pilot regulator			
Degree of filtration		5µm 20µm 50µm			
Max. inlet pressure	MPa	1.3			
	bar	13			
	psi	188			
Flow rate at 6.3 bar	Nl/min	9000		14000	
	scfm	320		500	
Fluid		Compressed air			
Max temperature at 10 bar	°C	50			
	°F	122			
Weight	Kg	10~			
Wall fixing screws		M6x110			
Mounting		Vertical			
Bowl capacity	cm³	270			
Note on use		The end plates in the 400 series have a patented system with a rotary and sliding end joint to adapt the unit perfectly to the pipe cutting distance. This unit does not include a pilot regulator. The maximum inlet pressure for the version with RA automatic condensate drainage must not exceed 10 bar.			



DIMENSIONS		FIL+REG+LUB 400			
THREADED PORT G		G1"	G1"1/4"	G1"1/2"	G2"
A		436-466		494-524	
B		444			
C		116			
E		352			
F		80			
L		M6 hole			

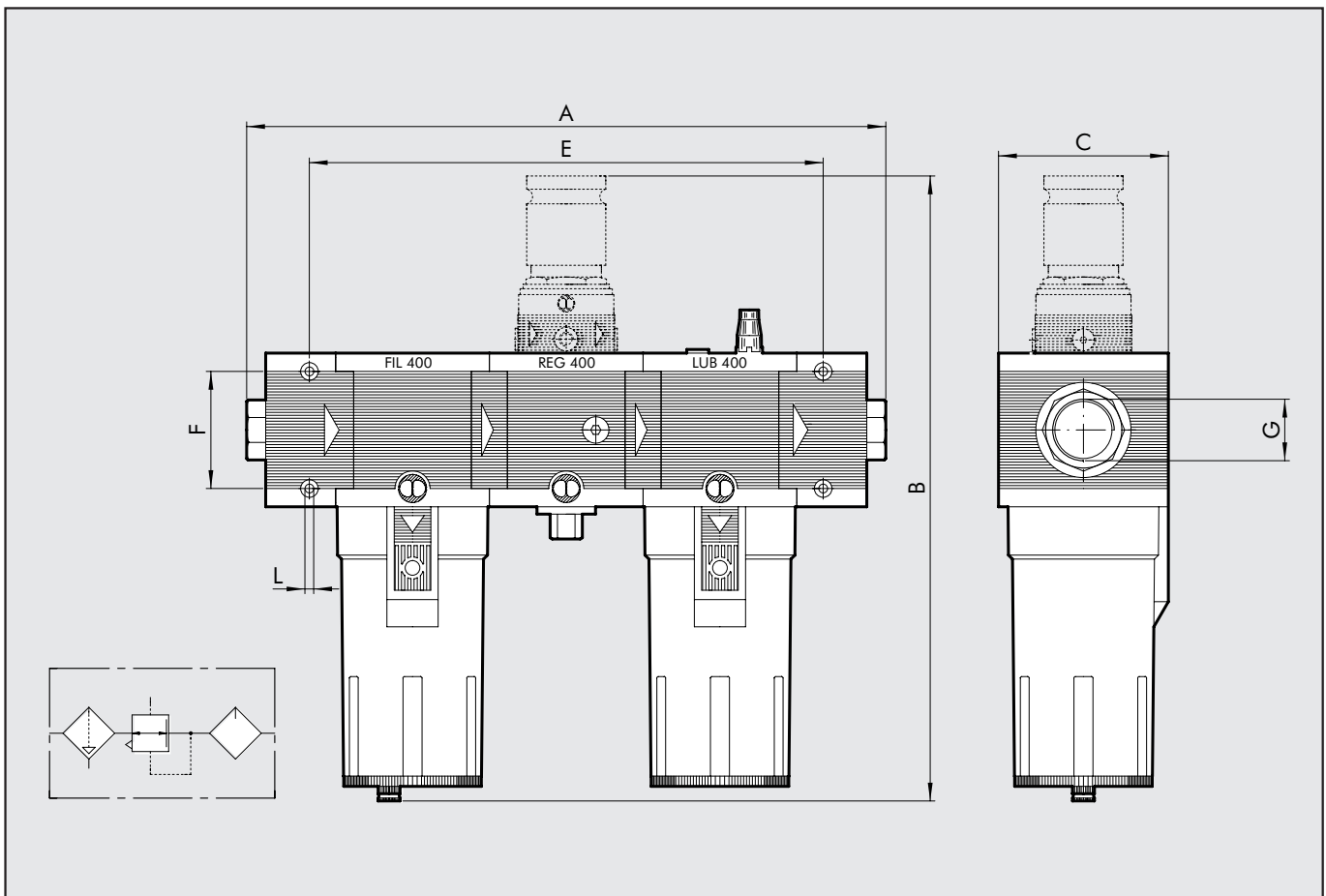

KEY TO CODES

FRL ELEMENT	100 SIZE	1/4 THREADED PORT	5µm DEGREE OF FILTRATION	0÷8 SETTING RANGE	RMSA TYPE OF CONDENSATION DRAIN
FRL	100	1/4 3/8	5µm 20µm 50µm	0÷8 bar 0÷12 bar	RMSA SAC RMSA SAC RA* RMSA RA
	200	1/4 3/8 1/2			
	300	1/2 3/4 1			
	400	1 1 1/4 1 1/2 2			

RMSA: Manual/semi-auto drain
SAC: Automatic drain for sizes 100 and 200. Operates by depression – requires variable air take-offs.

RA: Drain for size 300 and 400. Float-type operation irrespective of the pressure and flow rate.

* For SK200 with RA, please contact our sales assistance department

ORDERING CODES

Code	Description	Code	Description	Code	Description
3282007	FRL 100 1/4 5 08 RMSA	3582108	FRL 200 3/8 20 08 SAC	4682004	FRL 300 1 5 08 RMSA
3282008	FRL 100 1/4 20 08 RMSA	3582109	FRL 200 3/8 50 08 SAC	4682005	FRL 300 1 20 08 RMSA
3282009	FRL 100 1/4 50 08 RMSA	3582110	FRL 200 3/8 5 012 SAC	4682006	FRL 300 1 50 08 RMSA
3282010	FRL 100 1/4 5 012 RMSA	3582111	FRL 200 3/8 20 012 SAC	4682007	FRL 300 1 5 012 RMSA
3282011	FRL 100 1/4 20 012 RMSA	3582112	FRL 200 3/8 50 012 SAC	4682008	FRL 300 1 20 012 RMSA
3282012	FRL 100 1/4 50 012 RMSA	3682007	FRL 200 1/2 5 08 RMSA	4682009	FRL 300 1 50 012 RMSA
3282107	FRL 100 1/4 5 08 SAC	3682008	FRL 200 1/2 20 08 RMSA	4682013	FRL 300 1 5 08 RA
3282108	FRL 100 1/4 20 08 SAC	3682009	FRL 200 1/2 50 08 RMSA	4682014	FRL 300 1 20 08 RA
3282109	FRL 100 1/4 50 08 SAC	3682010	FRL 200 1/2 5 012 RMSA	4682015	FRL 300 1 50 08 RA
3282110	FRL 100 1/4 5 012 SAC	3682011	FRL 200 1/2 20 012 RMSA	4682016	FRL 300 1 5 012 RA
3282111	FRL 100 1/4 20 012 SAC	3682012	FRL 200 1/2 50 012 RMSA	4682017	FRL 300 1 20 012 RA
3282112	FRL 100 1/4 50 012 SAC	3682019	FRL 200 1/2 5 08 RA	4682018	FRL 300 1 50 012 RA
3382007	FRL 100 3/8 5 08 RMSA	3682020	FRL 200 1/2 20 08 RA	6182001	FRL 400 1 5 RMSA
3382008	FRL 100 3/8 20 08 RMSA	3682107	FRL 200 1/2 5 08 SAC	6182002	FRL 400 1 20 RMSA
3382009	FRL 100 3/8 50 08 RMSA	3682108	FRL 200 1/2 20 08 SAC	6182003	FRL 400 1 50 RMSA
3382010	FRL 100 3/8 5 012 RMSA	3682109	FRL 200 1/2 50 08 SAC	6182004	FRL 400 1 5 RA
3382011	FRL 100 3/8 20 012 RMSA	3682110	FRL 200 1/2 5 012 SAC	6182005	FRL 400 1 20 RA
3382012	FRL 100 3/8 50 012 RMSA	3682111	FRL 200 1/2 20 012 SAC	6182006	FRL 400 1 50 RA
3382107	FRL 100 3/8 5 08 SAC	3682112	FRL 200 1/2 50 012 SAC	6282001	FRL 400 1 1/4 5 RMSA
3382108	FRL 100 3/8 20 08 SAC	4482004	FRL 300 1/2 5 08 RMSA	6282002	FRL 400 1 1/4 20 RMSA
3382109	FRL 100 3/8 50 08 SAC	4482005	FRL 300 1/2 20 08 RMSA	6282003	FRL 400 1 1/4 50 RMSA
3382110	FRL 100 3/8 5 012 SAC	4482006	FRL 300 1/2 50 08 RMSA	6282004	FRL 400 1 1/4 5 RA
3382111	FRL 100 3/8 20 012 SAC	4482007	FRL 300 1/2 5 012 RMSA	6282005	FRL 400 1 1/4 20 RA
3382112	FRL 100 3/8 50 012 SAC	4482008	FRL 300 1/2 20 012 RMSA	6282006	FRL 400 1 1/4 50 RA
3482007	FRL 200 1/4 5 08 RMSA	4482009	FRL 300 1/2 50 012 RMSA	6382001	FRL 400 1 1/2 5 RMSA
3482008	FRL 200 1/4 20 08 RMSA	4482013	FRL 300 1/2 5 08 RA	6382002	FRL 400 1 1/2 20 RMSA
3482009	FRL 200 1/4 50 08 RMSA	4482014	FRL 300 1/2 20 08 RA	6382003	FRL 400 1 1/2 50 RMSA
3482010	FRL 200 1/4 5 012 RMSA	4482015	FRL 300 1/2 50 08 RA	6382004	FRL 400 1 1/2 5 RA
3482011	FRL 200 1/4 20 012 RMSA	4482016	FRL 300 1/2 5 012 RA	6382005	FRL 400 1 1/2 20 RA
3482012	FRL 200 1/4 50 012 RMSA	4482017	FRL 300 1/2 20 012 RA	6382006	FRL 400 1 1/2 50 RA
3482107	FRL 200 1/4 5 08 SAC	4482018	FRL 300 1/2 50 012 RA	6482001	FRL 400 2 5 RMSA
3482108	FRL 200 1/4 20 08 SAC	4582004	FRL 300 3/4 5 08 RMSA	6482002	FRL 400 2 20 RMSA
3482109	FRL 200 1/4 50 08 SAC	4582005	FRL 300 3/4 20 08 RMSA	6482003	FRL 400 2 50 RMSA
3482110	FRL 200 1/4 5 012 SAC	4582006	FRL 300 3/4 50 08 RMSA	6482004	FRL 400 2 5 RA
3482111	FRL 200 1/4 20 012 SAC	4582007	FRL 300 3/4 5 012 RMSA	6482005	FRL 400 2 20 RA
3482112	FRL 200 1/4 50 012 SAC	4582008	FRL 300 3/4 20 012 RMSA	6482006	FRL 400 2 50 RA
3582007	FRL 200 3/8 5 08 RMSA	4582009	FRL 300 3/4 50 012 RMSA		
3582008	FRL 200 3/8 20 08 RMSA	4582013	FRL 300 3/4 5 08 RA		
3582009	FRL 200 3/8 50 08 RMSA	4582014	FRL 300 3/4 20 08 RA		
3582010	FRL 200 3/8 5 012 RMSA	4582015	FRL 300 3/4 50 08 RA		
3582011	FRL 200 3/8 20 012 RMSA	4582016	FRL 300 3/4 5 012 RA		
3582012	FRL 200 3/8 50 012 RMSA	4582017	FRL 300 3/4 20 012 RA		
3582107	FRL 200 3/8 5 08 SAC	4582018	FRL 300 3/4 50 012 RA		

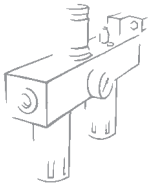

FR+LUB Skillair® 100-200-300

TECHNICAL DATA	FR+L 100		FR+L 200		FR+L 300	
Threaded port	1/4"	3/8"	1/4"	3/8" 1/2"	1/2"	3/4" 1"
Setting range	0 to 8 - 0 to 12		0 to 8 0 to 12		0 to 8 0 to 12	
Degree of filtration	5µm 20µm 50µm					
Max. inlet pressure	MPa	1.5	1.3		1.3	
	bar	15	13		13	
	psi	217	188		188	
Flow rate at 6.3 bar	NI/min	300	1200		2300	
ΔP 0.5 bar	scfm	11	43		82	
Flow rate at 6.3 bar	NI/min	800	2400		4000	
ΔP 1 bar	scfm	28	85		142	
Fluid	Compressed air					
Max temperature	°C	50	50		50	
	°F	122	122		122	
Weight	Kg	0.7	1.35		2.7	
Wall fixing screws		M4x50	M4x60		M5x70	
Note on use	The maximum inlet pressure for the version with RA automatic condensate drainage must not exceed 10 bar.					



DIMENSIONS	FR+LUB 100		FR+LUB 200			FR+LUB 300		
THREADED PORT G	G 1/4	G 3/8	G 1/4	G 3/8	G 1/2	G 1/2	G 3/4	G 1"
A	121		149			175		
B	199		245			278		
C	50		63			72		
E	106		134			157		
F	26		36			42		
L	M4 hole		M5 hole			M5 hole		

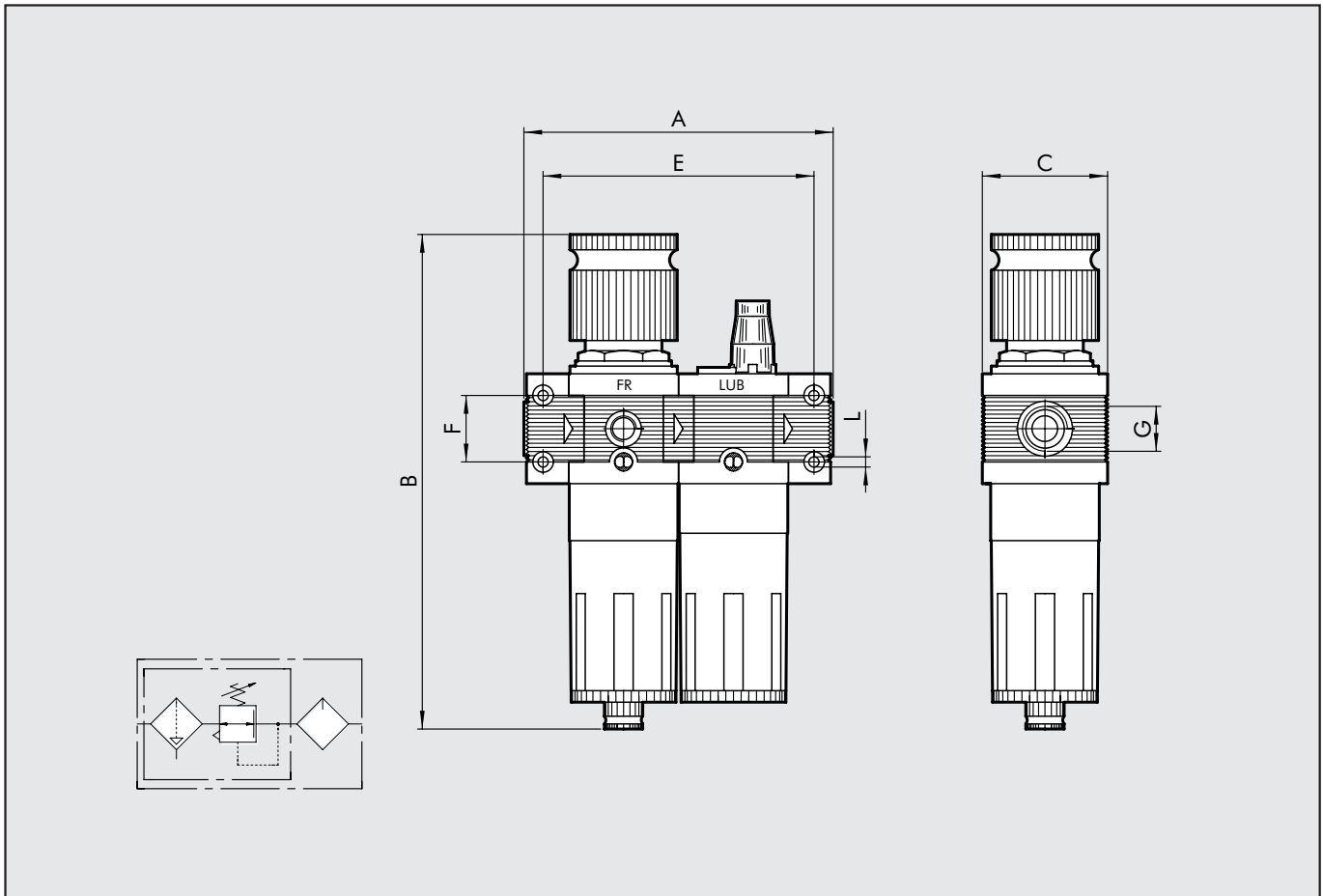

KEY TO CODES

FR+L ELEMENT	100 SIZE	1/4 THREADED PORT	5µm DEGREE OF FILTRATION	0÷8 SETTING RANGE	RMSA TYPE OF CONDENSATION RANGE
FR+L	100	1/4 3/8	5µm 20µm 50µm	0÷8 bar 0÷12 bar	RMSA SAC RMSA SAC RA* RMSA RA
	200	1/4 3/8 1/2			
	300	1/2 3/4 1			

RMSA: Manual/semi-auto drain
SAC: Automatic drain for sizes 100 and 200. Operates by depression – requires variable air take-offs.
RA: Drain for size 300 and 400. Float-type operation irrespective of the pressure and flow rate.

* For SK200 with RA, please contact our sales assistance department

ORDERING CODES

Code	Description	Code	Description	Code	Description
3284007	FR+L 100 1/4 5 08 RMSA	3584108	FR+L 200 3/8 20 08 SAC	4684004	FR+L 300 1 5 08 RMSA
3284008	FR+L 100 1/4 20 08 RMSA	3584109	FR+L 200 3/8 50 08 SAC	4684005	FR+L 300 1 20 08 RMSA
3284009	FR+L 100 1/4 50 08 RMSA	3584110	FR+L 200 3/8 5 012 SAC	4684006	FR+L 300 1 50 08 RMSA
3284010	FR+L 100 1/4 5 012 RMSA	3584111	FR+L 200 3/8 20 012 SAC	4684007	FR+L 300 1 5 012 RMSA
3284011	FR+L 100 1/4 20 012 RMSA	3584112	FR+L 200 3/8 50 012 SAC	4684008	FR+L 300 1 20 012 RMSA
3284012	FR+L 100 1/4 50 012 RMSA	3684007	FR+L 200 1/2 5 08 RMSA	4684009	FR+L 300 1 50 012 RMSA
3284107	FR+L 100 1/4 5 08 SAC	3684008	FR+L 200 1/2 20 08 RMSA	4684013	FR+L 300 1 5 08 RA
3284108	FR+L 100 1/4 20 08 SAC	3684009	FR+L 200 1/2 50 08 RMSA	4684014	FR+L 300 1 20 08 RA
3284109	FR+L 100 1/4 50 08 SAC	3684010	FR+L 200 1/2 5 012 RMSA	4684015	FR+L 300 1 50 08 RA
3284110	FR+L 100 1/4 5 012 SAC	3684011	FR+L 200 1/2 20 012 RMSA	4684016	FR+L 300 1 5 012 RA
3284111	FR+L 100 1/4 20 012 SAC	3684012	FR+L 200 1/2 50 012 RMSA	4684017	FR+L 300 1 20 012 RA
3284112	FR+L 100 1/4 50 012 SAC	3684107	FR+L 200 1/2 5 08 SAC	4684018	FR+L 300 1 50 012 RA
3384007	FR+L 100 3/8 5 08 RMSA	3684108	FR+L 200 1/2 20 08 SAC		
3384008	FR+L 100 3/8 20 08 RMSA	3684109	FR+L 200 1/2 50 08 SAC		
3384009	FR+L 100 3/8 50 08 RMSA	3684110	FR+L 200 1/2 5 012 SAC		
3384010	FR+L 100 3/8 5 012 RMSA	3684111	FR+L 200 1/2 20 012 SAC		
3384011	FR+L 100 3/8 20 012 RMSA	3684112	FR+L 200 1/2 50 012 SAC		
3384012	FR+L 100 3/8 50 012 RMSA	3684019	FR+L 200 1/2 5 08 RA		
3384107	FR+L 100 3/8 5 08 SAC	3684020	FR+L 200 1/2 20 08 RA		
3384108	FR+L 100 3/8 20 08 SAC	4484004	FR+L 300 1/2 5 08 RMSA		
3384109	FR+L 100 3/8 50 08 SAC	4484005	FR+L 300 1/2 20 08 RMSA		
3384110	FR+L 100 3/8 5 012 SAC	4484006	FR+L 300 1/2 50 08 RMSA		
3384111	FR+L 100 3/8 20 012 SAC	4484007	FR+L 300 1/2 5 012 RMSA		
3384112	FR+L 100 3/8 50 012 SAC	4484008	FR+L 300 1/2 20 012 RMSA		
3484007	FR+L 200 1/4 5 08 RMSA	4484009	FR+L 300 1/2 50 012 RMSA		
3484008	FR+L 200 1/4 20 08 RMSA	4484013	FR+L 300 1/2 5 08 RA		
3484009	FR+L 200 1/4 50 08 RMSA	4484014	FR+L 300 1/2 20 08 RA		
3484010	FR+L 200 1/4 5 012 RMSA	4484015	FR+L 300 1/2 50 08 RA		
3484011	FR+L 200 1/4 20 012 RMSA	4484016	FR+L 300 1/2 5 012 RA		
3484012	FR+L 200 1/4 50 012 RMSA	4484017	FR+L 300 1/2 20 012 RA		
3484107	FR+L 200 1/4 5 08 SAC	4484018	FR+L 300 1/2 50 012 RA		
3484108	FR+L 200 1/4 20 08 SAC	4584004	FR+L 300 3/4 5 08 RMSA		
3484109	FR+L 200 1/4 50 08 SAC	4584005	FR+L 300 3/4 20 08 RMSA		
3484110	FR+L 200 1/4 5 012 SAC	4584006	FR+L 300 3/4 50 08 RMSA		
3484111	FR+L 200 1/4 20 012 SAC	4584007	FR+L 300 3/4 5 012 RMSA		
3484112	FR+L 200 1/4 50 012 SAC	4584008	FR+L 300 3/4 20 012 RMSA		
3584007	FR+L 200 3/8 5 08 RMSA	4584009	FR+L 300 3/4 50 012 RMSA		
3584008	FR+L 200 3/8 20 08 RMSA	4584013	FR+L 300 3/4 5 08 RA		
3584009	FR+L 200 3/8 50 08 RMSA	4584014	FR+L 300 3/4 20 08 RA		
3584010	FR+L 200 3/8 5 012 RMSA	4584015	FR+L 300 3/4 50 08 RA		
3584011	FR+L 200 3/8 20 012 RMSA	4584016	FR+L 300 3/4 5 012 RA		
3584012	FR+L 200 3/8 50 012 RMSA	4584017	FR+L 300 3/4 20 012 RA		
3584107	FR+L 200 3/8 5 08 SAC	4584018	FR+L 300 3/4 50 012 RA		

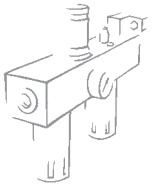

V3V+FIL+REG+LUB Skillair® 100-200-300

TECHNICAL DATA	VFRL 100	VFRL 200	VFRL 300
Threaded port	1/4" 3/8"	1/4" 3/8" 1/2"	1/2" 3/4" 1"
Setting range	0 to 8 - 0 to 12	0 to 8 0 to 12	0 to 8 0 to 12
Degree of filtration	5µm 20µm 50µm		
Max. inlet pressure	MPa 1.5 bar 15 psi 217	1.3 13 188	1.3 13 188
Flow rate at 6.3 bar	Nl/min 300	1300	2200
ΔP 0.5 bar	scfm 11	46	82
Flow rate at 6.3 bar	Nl/min 800	2500	4000
ΔP 1 bar	scfm 28	89	142
Fluid	Compressed air		
Max temperature at 10 bar	°C 50 °F 122	50 122	50 122
Weight	Kg 1	2	3.5
Wall fixing screws	M4x50	M5x60	M5x70
Note on use	The maximum inlet pressure for the version with RA automatic condensate drainage must not exceed 10 bar.		



DIMENSIONS	V3V+FIL+REG+LUB 100		V3V+FIL+REG+LUB 200			V3V+FIL+REG+LUB 300		
THREADED PORT G	G 1/4	G 3/8	G 1/4	G 3/8	G 1/2	G 1/2	G 3/4	G 1"
A	207			260		305		307
B	199			245			278	
C	50			63			72	
E	192			245			287	
F	26			36			42	
L	M4 hole			M5 hole			M5 hole	

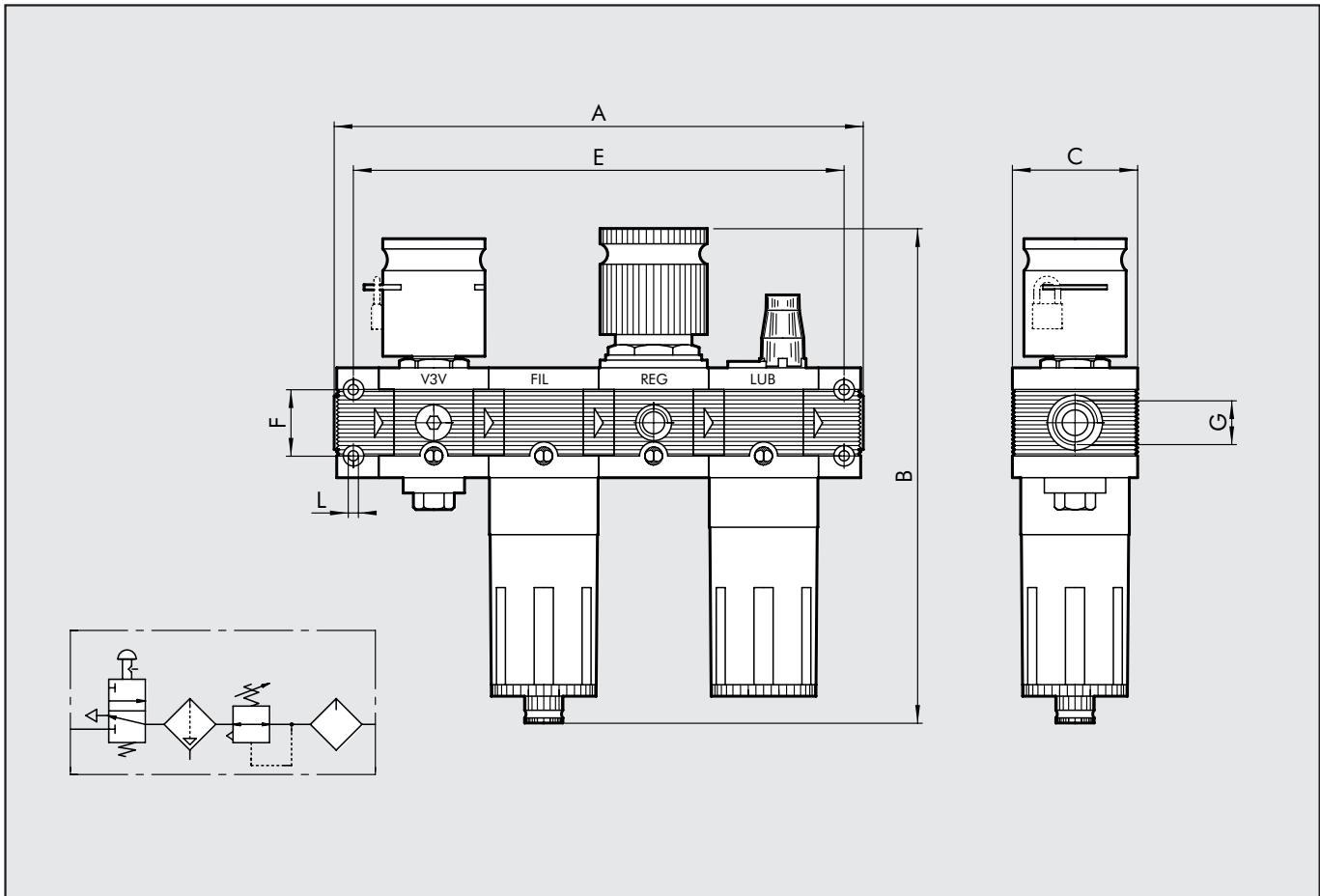

V3V+FIL+REG+LUB Skillair® 400

TECHNICAL DATA		VFRL 400			
Threaded port		G1"	G1"1/4"	G1"1/2"	G2"
Setting range		Depending on pilot regulator			
Degree of filtration		5µm 20µm 50µm			
Max. inlet pressure	MPa	1.3			
	bar	13			
	psi	188			
Flow rate at 6.3 bar		VFRL 400 1": 9000 NI/min = 320 scfm			
ΔP 0.5 bar		VFRL 400 2": 14.000 NI/min = 500 scfm			
Fluid		Compressed air			
Max temperature	°C	50			
	°F	122			
Weight	Kg	12~			
Wall fixing screws		M6x110			
Mounting		Vertical			
Bowl capacity	cm³	270			
Note on use		The maximum inlet pressure for the version with RA automatic condensate drainage must not exceed 10 bar.			

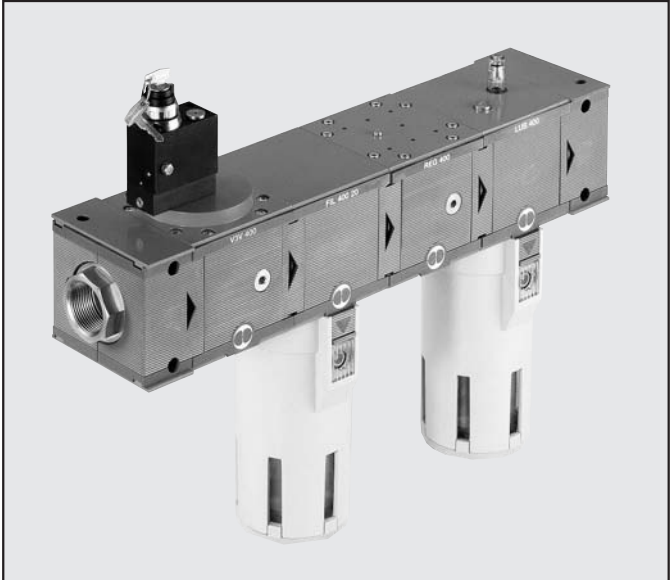

Notes: The end plates in the 400 series have a patented system with a rotary and sliding end joint to adapt the unit perfectly to the pipe cutting distance. This unit does not include a pilot regulator. The pilot regulator must be piloted at a pressure taken upstream of the V3V, otherwise when the system is relieved, most of the air downstream will be relieved by the regulator and not the V3V relief port. For connecting instruction see page 3.1/15.

DIMENSIONS		V3V+FIL+REG+LUB 400			
THREADED PORT G		G1"	G1"1/4"	G1"1/2"	G2"
A		541-571			599-629
B		461			
E		457.5			
F		80			
L		M6 hole			

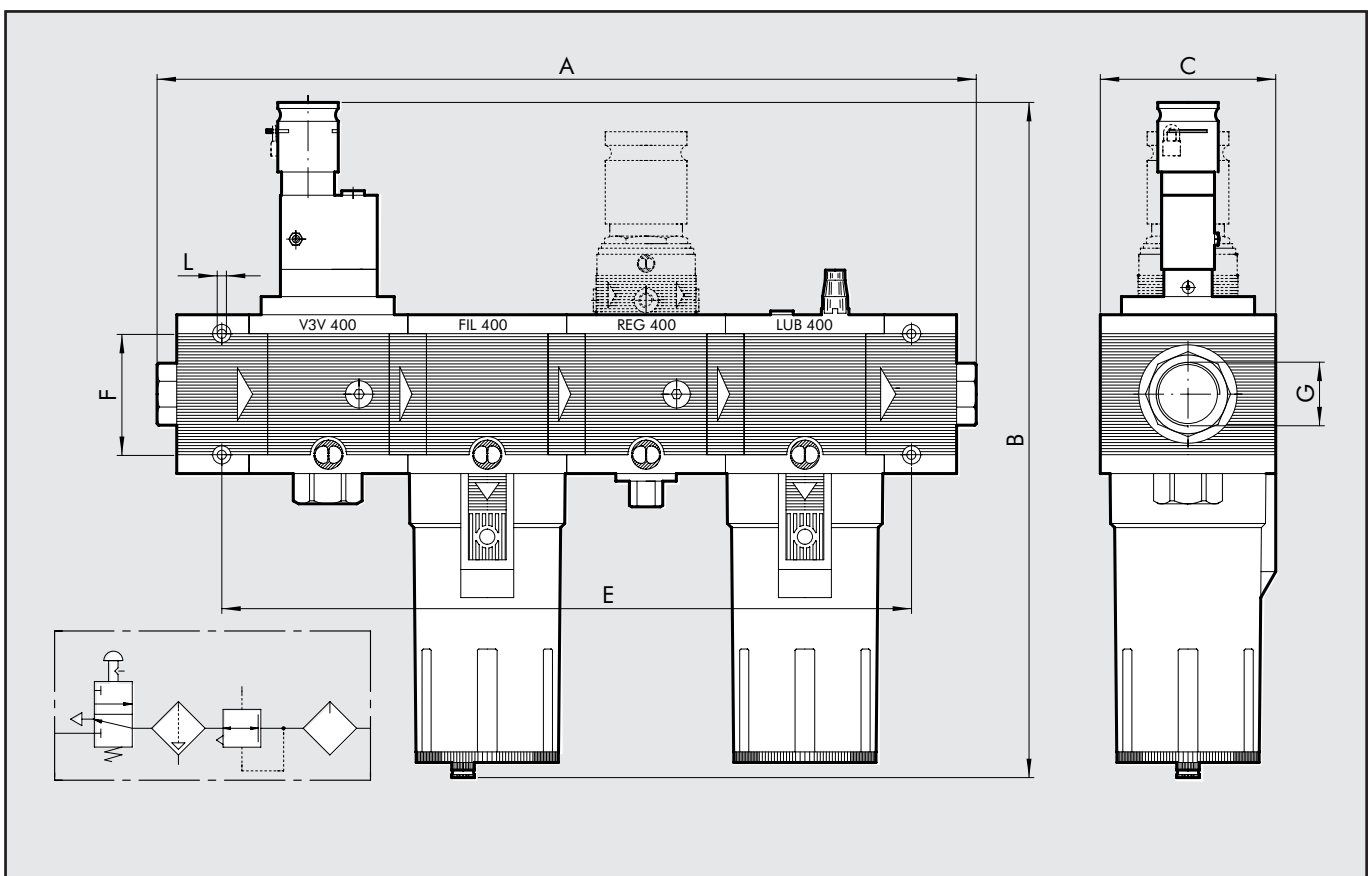

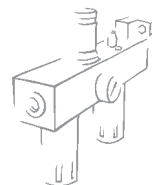

KEY TO CODES

VFRL	100	1/4	5µm	0÷8	RMSA
ELEMENT	SIZE	THREADED PORT	DEGREE OF FILTRATION	SETTING RANGE	TYPE OF CONDENSATE DRAIN
VFRL	100	1/4 3/8	5µm 20µm 50µm	0÷8 bar 0÷12 bar	RMSA
	200	1/4 3/8 1/2			SAC
		300			1/2 3/4 1
	400				1
1 1/4		RMSA			
1 1/2 2		RA			

RMSA: Manual/semi-auto drain
SAC: Automatic drain for sizes 100 and 200. Operates by depression – requires variable air take-offs.
RA: Drain for size 300 and 400. Float-type operation irrespective of the pressure and flow rate.

* For SK200 with RA, please contact our sales assistance department

ORDERING CODES

Code	Description	Code	Description	Code	Description
3273007	VFRL 100 1/4 5 08 RMSA	3573108	VFRL 200 3/8 20 08 SAC	4673006	VFRL 300 1 50 08 RMSA
3273008	VFRL 100 1/4 20 08 RMSA	3573109	VFRL 200 3/8 50 08 SAC	4673007	VFRL 300 1 5 012 RMSA
3273009	VFRL 100 1/4 50 08 RMSA	3573110	VFRL 200 3/8 5 012 SAC	4673008	VFRL 300 1 20 012 RMSA
3273010	VFRL 100 1/4 5 012 RMSA	3573111	VFRL 200 3/8 20 012 SAC	4673009	VFRL 300 1 50 012 RMSA
3273011	VFRL 100 1/4 20 012 RMSA	3573112	VFRL 200 3/8 50 012 SAC	4673013	VFRL 300 1 5 08 RA
3273012	VFRL 100 1/4 50 012 RMSA	3673007	VFRL 200 1/2 5 08 RMSA	4673014	VFRL 300 1 20 08 RA
3273107	VFRL 100 1/4 5 08 SAC	3673008	VFRL 200 1/2 20 08 RMSA	4673015	VFRL 300 1 50 08 RA
3273108	VFRL 100 1/4 20 08 SAC	3673009	VFRL 200 1/2 50 08 RMSA	4673016	VFRL 300 1 5 012 RA
3273109	VFRL 100 1/4 50 08 SAC	3673010	VFRL 200 1/2 5 012 RMSA	4673017	VFRL 300 1 20 012 RA
3273110	VFRL 100 1/4 5 012 SAC	3673011	VFRL 200 1/2 20 012 RMSA	4673018	VFRL 300 1 50 012 RA
3273111	VFRL 100 1/4 20 012 SAC	3673012	VFRL 200 1/2 50 012 RMSA	6173001	VFRL 400 1 5 RMSA
3273112	VFRL 100 1/4 50 012 SAC	3673107	VFRL 200 1/2 5 08 SAC	6173002	VFRL 400 1 20 RMSA
3373007	VFRL 100 3/8 5 08 RMSA	3673108	VFRL 200 1/2 20 08 SAC	6173003	VFRL 400 1 50 RMSA
3373008	VFRL 100 3/8 20 08 RMSA	3673109	VFRL 200 1/2 50 08 SAC	6173004	VFRL 400 1 5 RA
3373009	VFRL 100 3/8 50 08 RMSA	3673110	VFRL 200 1/2 5 012 SAC	6173005	VFRL 400 1 20 RA
3373010	VFRL 100 3/8 5 012 RMSA	3673111	VFRL 200 1/2 20 012 SAC	6173006	VFRL 400 1 50 RA
3373011	VFRL 100 3/8 20 012 RMSA	3673112	VFRL 200 1/2 50 012 SAC	6273001	VFRL 400 1 1/4 5 RMSA
3373012	VFRL 100 3/8 50 012 RMSA	4473004	VFRL 300 1/2 5 08 RMSA	6273002	VFRL 400 1 1/4 20 RMSA
3373107	VFRL 100 3/8 5 08 SAC	4473005	VFRL 300 1/2 20 08 RMSA	6273003	VFRL 400 1 1/4 50 RMSA
3373108	VFRL 100 3/8 20 08 SAC	4473006	VFRL 300 1/2 50 08 RMSA	6273004	VFRL 400 1 1/4 5 RA
3373109	VFRL 100 3/8 50 08 SAC	4473007	VFRL 300 1/2 5 012 RMSA	6273005	VFRL 400 1 1/4 20 RA
3373110	VFRL 100 3/8 5 012 SAC	4473008	VFRL 300 1/2 20 012 RMSA	6273006	VFRL 400 1 1/4 50 RA
3373111	VFRL 100 3/8 20 012 SAC	4473009	VFRL 300 1/2 50 012 RMSA	6373001	VFRL 400 1 1/2 5 RMSA
3373112	VFRL 100 3/8 50 012 SAC	4473013	VFRL 300 1/2 5 08 RA	6373002	VFRL 400 1 1/2 20 RMSA
3473007	VFRL 200 1/4 5 08 RMSA	4473014	VFRL 300 1/2 20 08 RA	6373003	VFRL 400 1 1/2 50 RMSA
3473008	VFRL 200 1/4 20 08 RMSA	4473015	VFRL 300 1/2 50 08 RA	6373004	VFRL 400 1 1/2 5 RA
3473009	VFRL 200 1/4 50 08 RMSA	4473016	VFRL 300 1/2 5 012 RA	6373005	VFRL 400 1 1/2 20 RA
3473010	VFRL 200 1/4 5 012 RMSA	4473017	VFRL 300 1/2 20 012 RA	6373006	VFRL 400 1 1/2 50 RA
3473011	VFRL 200 1/4 20 012 RMSA	4473018	VFRL 300 1/2 50 012 RA	6473001	VFRL 400 2 5 RMSA
3473012	VFRL 200 1/4 50 012 RMSA	4573004	VFRL 300 3/4 5 08 RMSA	6473002	VFRL 400 2 20 RMSA
3473107	VFRL 200 1/4 5 08 SAC	4573005	VFRL 300 3/4 20 08 RMSA	6473003	VFRL 400 2 50 RMSA
3473108	VFRL 200 1/4 20 08 SAC	4573006	VFRL 300 3/4 50 08 RMSA	6473004	VFRL 400 2 5 RA
3473109	VFRL 200 1/4 50 08 SAC	4573007	VFRL 300 3/4 5 012 RMSA	6473005	VFRL 400 2 20 RA
3473110	VFRL 200 1/4 5 012 SAC	4573008	VFRL 300 3/4 20 012 RMSA	6473006	VFRL 400 2 50 RA
3473111	VFRL 200 1/4 20 012 SAC	4573009	VFRL 300 3/4 50 012 RMSA		
3473112	VFRL 200 1/4 50 012 SAC	4573013	VFRL 300 3/4 5 08 RA		
3573007	VFRL 200 3/8 5 08 RMSA	4573014	VFRL 300 3/4 20 08 RA		
3573008	VFRL 200 3/8 20 08 RMSA	4573015	VFRL 300 3/4 50 08 RA		
3573009	VFRL 200 3/8 50 08 RMSA	4573016	VFRL 300 3/4 5 012 RA		
3573010	VFRL 200 3/8 5 012 RMSA	4573017	VFRL 300 3/4 20 012 RA		
3573011	VFRL 200 3/8 20 012 RMSA	4573018	VFRL 300 3/4 50 012 RA		
3573012	VFRL 200 3/8 50 012 RMSA	4673004	VFRL 300 1 5 08 RMSA		
3573107	VFRL 200 3/8 5 08 SAC	4673005	VFRL 300 1 20 08 RMSA		

V3V+FR+LUB Skillair® 100-200-300

TECHNICAL DATA	V+FR+L 100		V+FR+L 200		V+FR+L 300	
Threaded port	1/4"	3/8"	1/4"	3/8"	1/2"	3/4" 1"
Setting range	0 to 8	0 to 12	0 to 8	0 to 12	0 to 8	0 to 12
Degree of filtration	5µm 20µm 50µm					
Max. inlet pressure	MPa	15	1.3	1.3	1.3	1.3
	bar	15	13	13	13	13
	psi	217	188	188	188	188
Flow rate at 6.3 bar	NI/min	300	1200	2300	2300	2300
ΔP 0.5 bar		11	43	82	82	82
Flow rate at 6.3 bar	NI/min	800	2400	4000	4000	4000
ΔP 1 bar		28	85	142	142	142
Fluid	Compressed air					
Max temperature	°C	50	50	50	50	50
at 10 bar	°F	122	122	122	122	122
Weight	Kg	1	1.8	3.2	3.2	3.2
Wall fixing screws		M4x50	M5x60	M5x70	M5x70	M5x70
Note on use	The maximum inlet pressure for the version with RA automatic condensate drainage must not exceed 10 bar.					

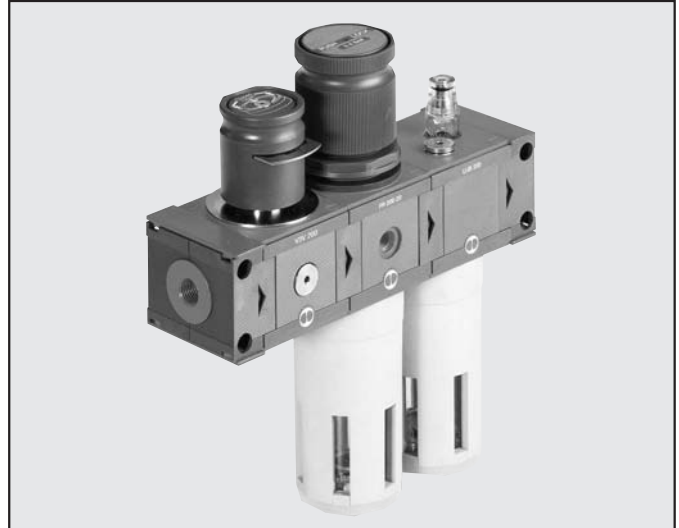

DIMENSIONS	V3V+FR 100		V3V+FR+LUB 200			V3V+FR+LUB 300		
THREADED PORT G	G 1/4	G 3/8	G 1/4	G 3/8	G 1/2	G 1/2	G 3/4	G 1"
A	164			204.5		240		242
B	199			245			278	
C	50			63			72	
E	149			189.5			222	
F	26			36			42	
L	M4 hole			M5 hole			M5 hole	

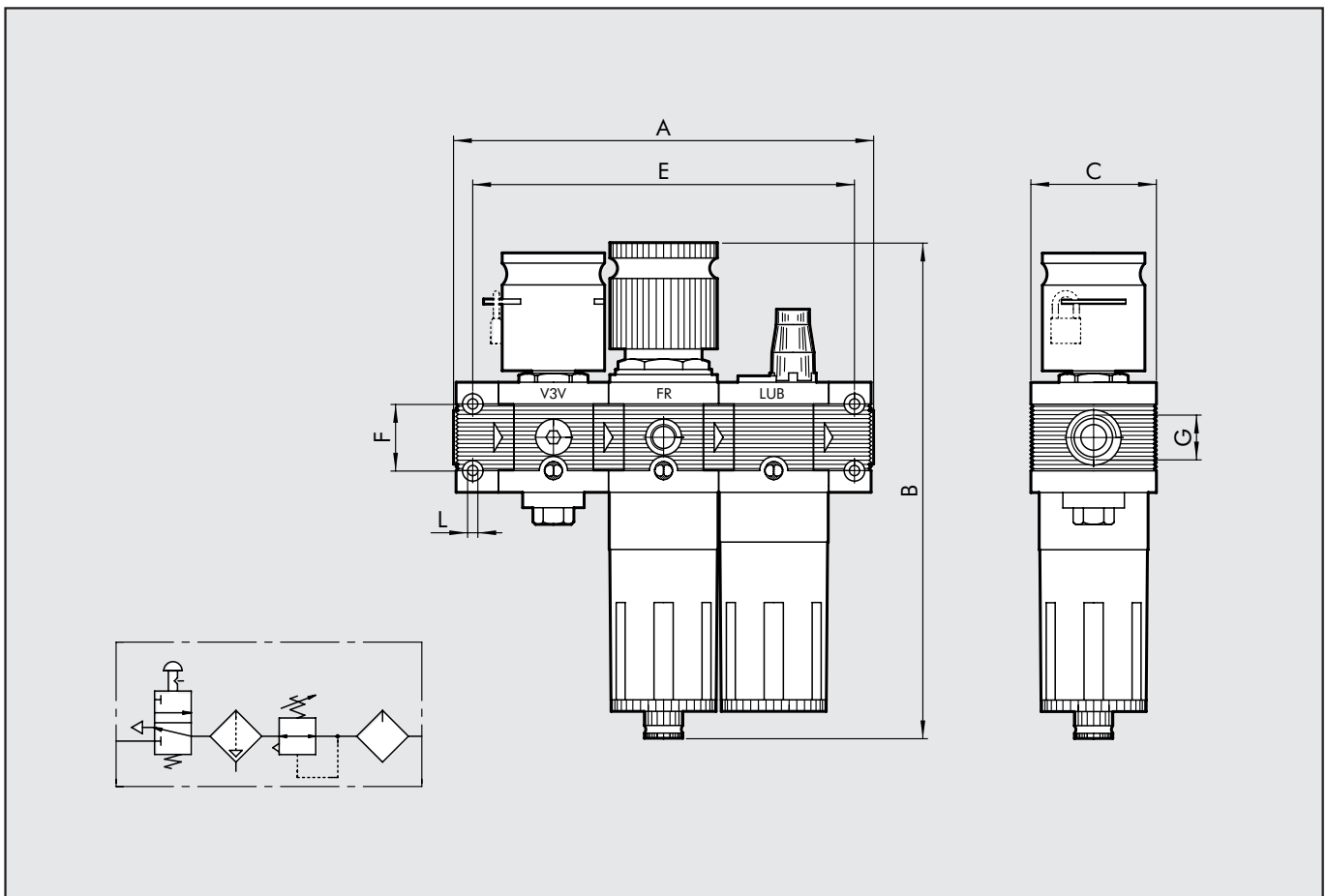



KEY TO CODES

VFR+L	100	1/4	5µm	0÷8	RMSA
ELEMENT	SIZE	THREADED PORT	DEGREE OF FILTRATION	SETTING RANGE	TYPE OF CONDENSATE DRAIN
VFR+L	100	1/4 3/8	5µm 20µm 50µm	0÷8 bar 0÷12 bar	RMSA SAC RMSA SAC RA* RMSA RA
	200	1/4 3/8 1/2			
	300	1/2 3/4 1			

RMSA: Manual/semi-auto drain
SAC: Automatic drain for sizes 100 and 200. Operates by depression – requires variable air take-offs.
RA: Drain for size 300 and 400. Float-type operation irrespective of the pressure and flow rate.

* For SK200 with RA, please contact our sales assistance department

ORDERING CODES

Code	Description	Code	Description	Code	Description
3272007	VFR+L 100 1/4 5 08 RMSA	3572108	VFR+L 200 3/8 20 08 SAC	4672006	VFR+L 300 1 50 08 RMSA
3272008	VFR+L 100 1/4 20 08 RMSA	3572109	VFR+L 200 3/8 50 08 SAC	4672007	VFR+L 300 1 5 012 RMSA
3272009	VFR+L 100 1/4 50 08 RMSA	3572110	VFR+L 200 3/8 5 012 SAC	4672008	VFR+L 300 1 20 012 RMSA
3272010	VFR+L 100 1/4 5 012 RMSA	3572111	VFR+L 200 3/8 20 012 SAC	4672009	VFR+L 300 1 50 012 RMSA
3272011	VFR+L 100 1/4 20 012 RMSA	3572112	VFR+L 200 3/8 50 012 SAC	4672013	VFR+L 300 1 5 08 RA
3272012	VFR+L 100 1/4 50 012 RMSA	3672007	VFR+L 200 1/2 5 08 RMSA	4672014	VFR+L 300 1 20 08 RA
3272107	VFR+L 100 1/4 5 08 SAC	3672008	VFR+L 200 1/2 20 08 RMSA	4672015	VFR+L 300 1 50 08 RA
3272108	VFR+L 100 1/4 20 08 SAC	3672009	VFR+L 200 1/2 50 08 RMSA	4672016	VFR+L 300 1 5 012 RA
3272109	VFR+L 100 1/4 50 08 SAC	3672010	VFR+L 200 1/2 5 012 RMSA	4672017	VFR+L 300 1 20 012 RA
3272110	VFR+L 100 1/4 5 012 SAC	3672011	VFR+L 200 1/2 20 012 RMSA	4672018	VFR+L 300 1 50 012 RA
3272111	VFR+L 100 1/4 20 012 SAC	3672012	VFR+L 200 1/2 50 012 RMSA		
3272112	VFR+L 100 1/4 50 012 SAC	3672107	VFR+L 200 1/2 5 08 SAC		
3372007	VFR+L 100 3/8 5 08 RMSA	3672108	VFR+L 200 1/2 20 08 SAC		
3372008	VFR+L 100 3/8 20 08 RMSA	3672109	VFR+L 200 1/2 50 08 SAC		
3372009	VFR+L 100 3/8 50 08 RMSA	3672110	VFR+L 200 1/2 5 012 SAC		
3372010	VFR+L 100 3/8 5 012 RMSA	3672111	VFR+L 200 1/2 20 012 SAC		
3372011	VFR+L 100 3/8 20 012 RMSA	3672112	VFR+L 200 1/2 50 012 SAC		
3372012	VFR+L 100 3/8 50 012 RMSA	4472004	VFR+L 300 1/2 5 08 RMSA		
3372107	VFR+L 100 3/8 5 08 SAC	4472005	VFR+L 300 1/2 20 08 RMSA		
3372108	VFR+L 100 3/8 20 08 SAC	4472006	VFR+L 300 1/2 50 08 RMSA		
3372109	VFR+L 100 3/8 50 08 SAC	4472007	VFR+L 300 1/2 5 012 RMSA		
3372110	VFR+L 100 3/8 5 012 SAC	4472008	VFR+L 300 1/2 20 012 RMSA		
3372111	VFR+L 100 3/8 20 012 SAC	4472009	VFR+L 300 1/2 50 012 RMSA		
3372112	VFR+L 100 3/8 50 012 SAC	4472013	VFR+L 300 1/2 5 08 RA		
3472007	VFR+L 200 1/4 5 08 RMSA	4472014	VFR+L 300 1/2 20 08 RA		
3472008	VFR+L 200 1/4 20 08 RMSA	4472015	VFR+L 300 1/2 50 08 RA		
3472009	VFR+L 200 1/4 50 08 RMSA	4472016	VFR+L 300 1/2 5 012 RA		
3472010	VFR+L 200 1/4 5 012 RMSA	4472017	VFR+L 300 1/2 20 012 RA		
3472011	VFR+L 200 1/4 20 012 RMSA	4472018	VFR+L 300 1/2 50 012 RA		
3472012	VFR+L 200 1/4 50 012 RMSA	4572004	VFR+L 300 3/4 5 08 RMSA		
3472107	VFR+L 200 1/4 5 08 SAC	4572005	VFR+L 300 3/4 20 08 RMSA		
3472108	VFR+L 200 1/4 20 08 SAC	4572006	VFR+L 300 3/4 50 08 RMSA		
3472109	VFR+L 200 1/4 50 08 SAC	4572007	VFR+L 300 3/4 5 012 RMSA		
3472110	VFR+L 200 1/4 5 012 SAC	4572008	VFR+L 300 3/4 20 012 RMSA		
3472111	VFR+L 200 1/4 20 012 SAC	4572009	VFR+L 300 3/4 50 012 RMSA		
3472112	VFR+L 200 1/4 50 012 SAC	4572013	VFR+L 300 3/4 5 08 RA		
3572007	VFR+L 200 3/8 5 08 RMSA	4572014	VFR+L 300 3/4 20 08 RA		
3572008	VFR+L 200 3/8 20 08 RMSA	4572015	VFR+L 300 3/4 50 08 RA		
3572009	VFR+L 200 3/8 50 08 RMSA	4572016	VFR+L 300 3/4 5 012 RA		
3572010	VFR+L 200 3/8 5 012 RMSA	4572017	VFR+L 300 3/4 20 012 RA		
3572011	VFR+L 200 3/8 20 012 RMSA	4572018	VFR+L 300 3/4 50 012 RA		
3572012	VFR+L 200 3/8 50 012 RMSA	4672004	VFR+L 300 1 5 08 RMSA		
3572107	VFR+L 200 3/8 5 08 SAC	4672005	VFR+L 300 1 20 08 RMSA		

FIL+LUB Skillair® 100-200-300

TECHNICAL DATA	F+L 100		F+L 200			F+L 300		
Threaded port	1/4"	3/8"	1/4"	3/8"	1/2"	1/2"	3/4"	1"
Degree of filtration	5µm 20µm 50µm							
Max. inlet pressure	MPa	1.5	1.3	1.3	1.3	1.3	1.3	1.3
	bar	15	13	13	13	13	13	13
	psi	217	188	188	188	188	188	188
Flow rate at 6.3 bar	NI/min	600	1800	3200	3200	4500	4500	4500
ΔP 0.5 bar	scfm	21	64	113	113	160	160	160
Flow rate at 6.3 bar	NI/min	1200	3200	4500	4500	4500	4500	4500
ΔP 1 bar	scfm	42	113	160	160	160	160	160
Fluid	Compressed air							
Max temperature	°C	50	50	50	50	50	50	50
at 10 bar	°F	122	122	122	122	122	122	122
Weight	Kg	0.5	1.1	1.1	2.2	2.2	2.2	2.2
Wall fixing screws		M4x50	M5x60	M5x60	M5x70	M5x70	M5x70	M5x70
Note on use	The maximum inlet pressure for the version with RA automatic condensate drainage must not exceed 10 bar.							



DIMENSIONS	FIL+LUB 100		FIL+LUB 200			FIL+LUB 300		
THREADED PORT G	G 1/4	G 3/8	G 1/4	G 3/8	G 1/2	G 1/2	G 3/4	G 1"
A	121		149			175		177
B	172.5		203.5			223.5		
C	50		63			72		
E	106		134			157		
F	26		36			42		
L	M4 hole		M5 hole			M5 hole		

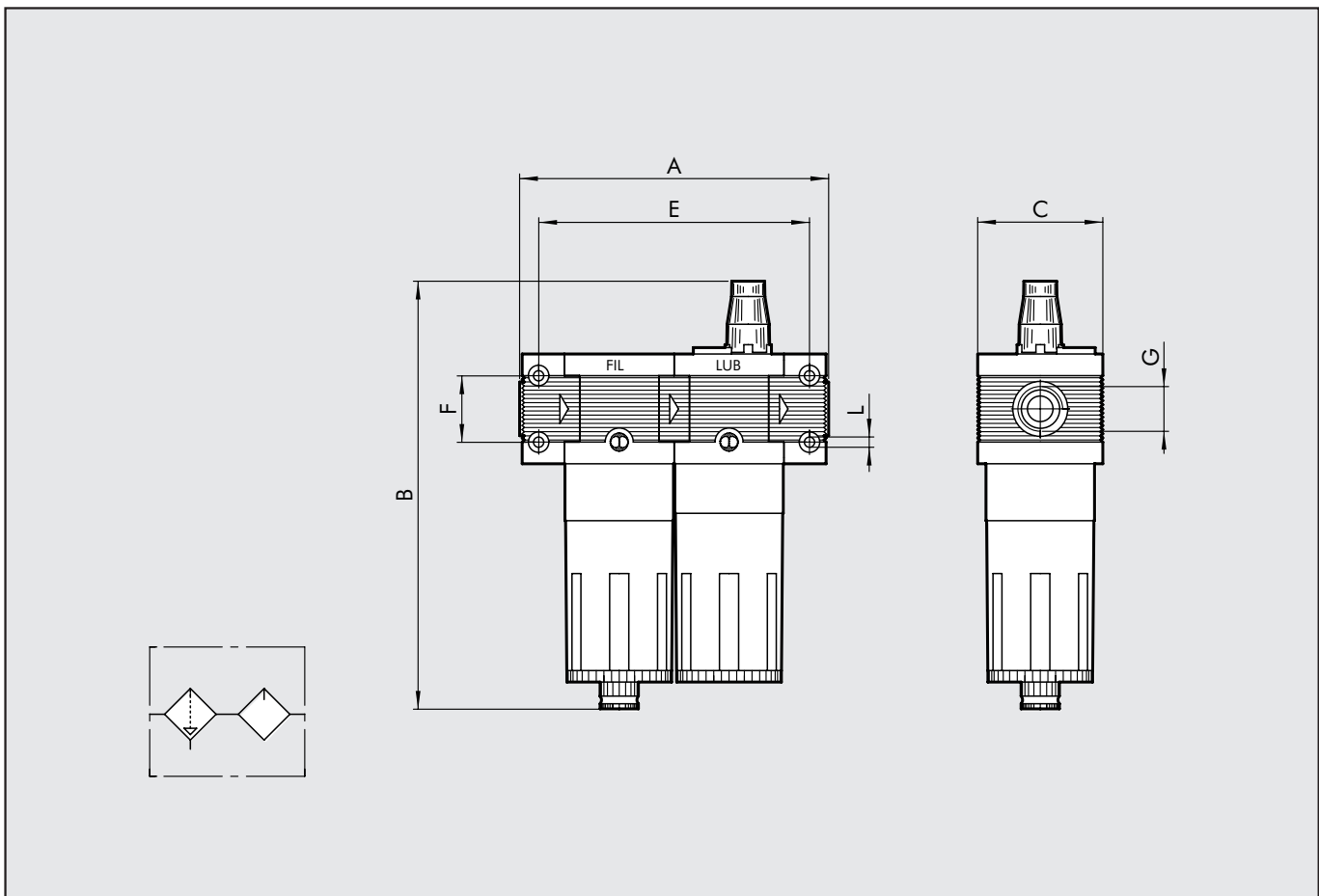

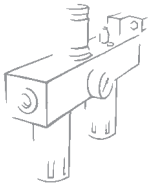

FIL+LUB Skillair® 400

TECHNICAL DATA		F+L 400			
Threaded port		G1"	G1"1/4"	G1"1/2"	G2"
Degree of filtration		5µm 20µm 50µm			
Max. inlet pressure	MPa	1.3			
	bar	13			
	psi	188			
Flow rate at 6.3 bar		F+L 400 1": 9000 NI/min = 320 scfm			
ΔP 0.5 bar		F+L 400 2": 14.000 NI/min = 500 scfm			
Fluid		Compressed air			
Max temperature	°C	50			
at 10 bar	°F	122			
Weight	Kg	8~			
Wall fixing screws		M6x110			
Mounting		Vertical			
Bowl capacity	cm ³	270			
Note on use		<p>The end plates in the 400 series have a patented system with a rotary and sliding end joint to adapt the unit perfectly to the pipe cutting distance.</p> <p>The maximum inlet pressure for the version with RA automatic condensate drainage must not exceed 10 bar.</p>			



DIMENSIONS		FIL+LUB 400			
THREADED PORT G		G1"	G1"1/4"	G1"1/2"	G2"
A			330-360		388-418
B				349.5	
C				116	
E				247	
F				80	
L				M6 hole	

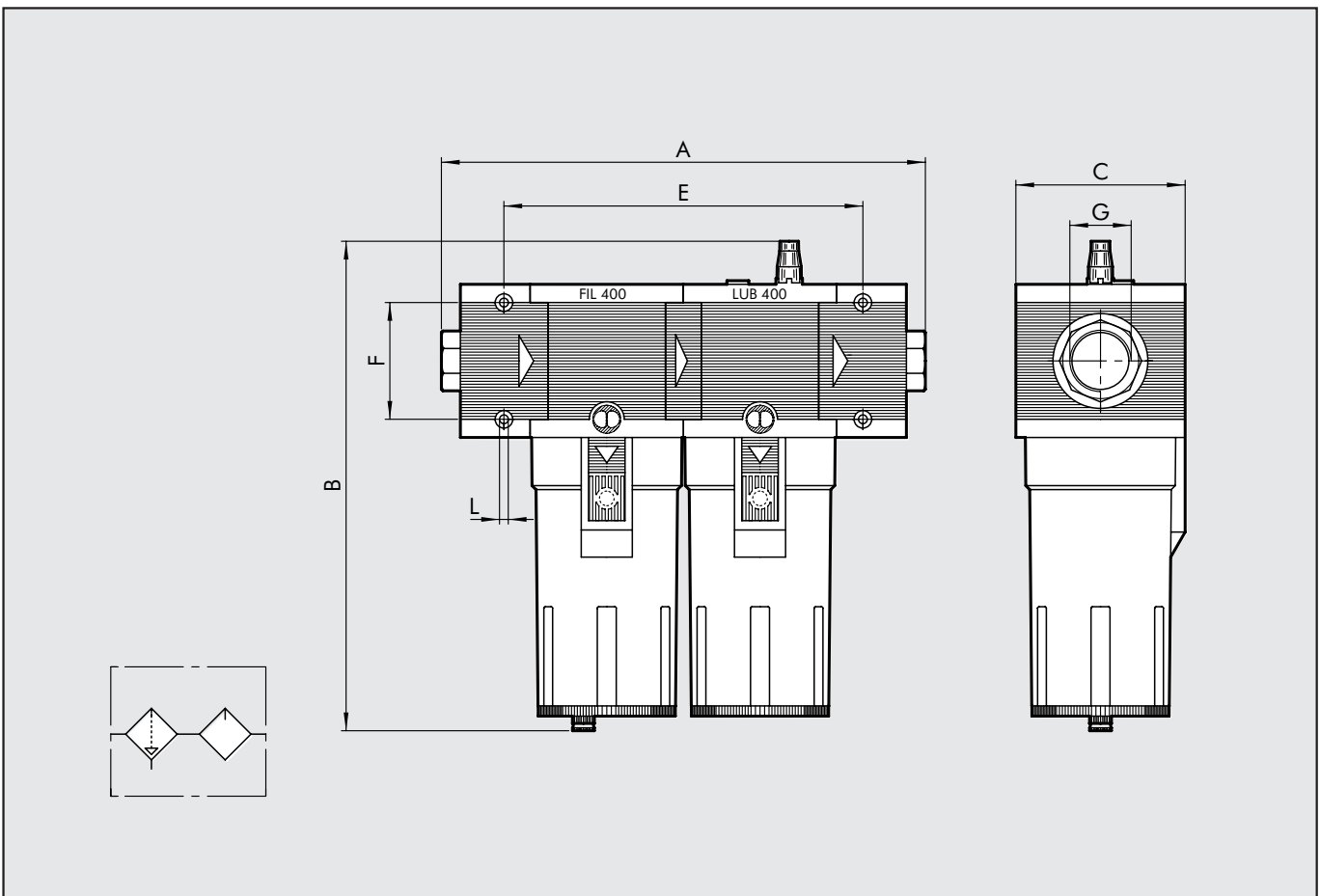

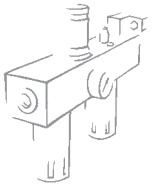

FIL+DEP Skillair® 100-200-300

TECHNICAL DATA	F+D 100		F+D 200			F+D 300		
Threaded port	1/4"	3/8"	1/4"	3/8"	1/2"	1/2"	3/4"	1"
Degree of filtration	Filter: 5µm - Depurator: 0.01µm							
Max. inlet pressure	MPa	1.5	1.3	1.3	1.3	1.3	1.3	1.3
	bar	15	13	13	13	13	13	13
	psi	217	188	188	188	188	188	188
Maximum suggested flow rate	Please look at the flow rate curves at page 3.1/33							
Fluid	Compressed air							
Max temperature	°C	50	50	50	50	50	50	50
at 10 bar	°F	122	122	122	122	122	122	122
Weight	Kg	0.6	1.3	1.3	2.2	2.2	2.2	2.2
Wall fixing screws		M4x50	M5x60	M5x60	M5x70	M5x70	M5x70	M5x70
Note on use	The maximum inlet pressure for the version with RA automatic condensate drainage must not exceed 10 bar.							



DIMENSIONS	FIL+DEP 100		FIL+DEP 200			FIL+DEP 300		
THREADED PORT G	G 1/4	G 3/8	G 1/4	G 3/8	G 1/2	G 1/2	G 3/4	G 1"
A	121		149			175		177
B	144		175				195	
C	50		63				72	
E	106		134				157	
F	26		36				42	
L	M4 hole		M5 hole				M5 hole	

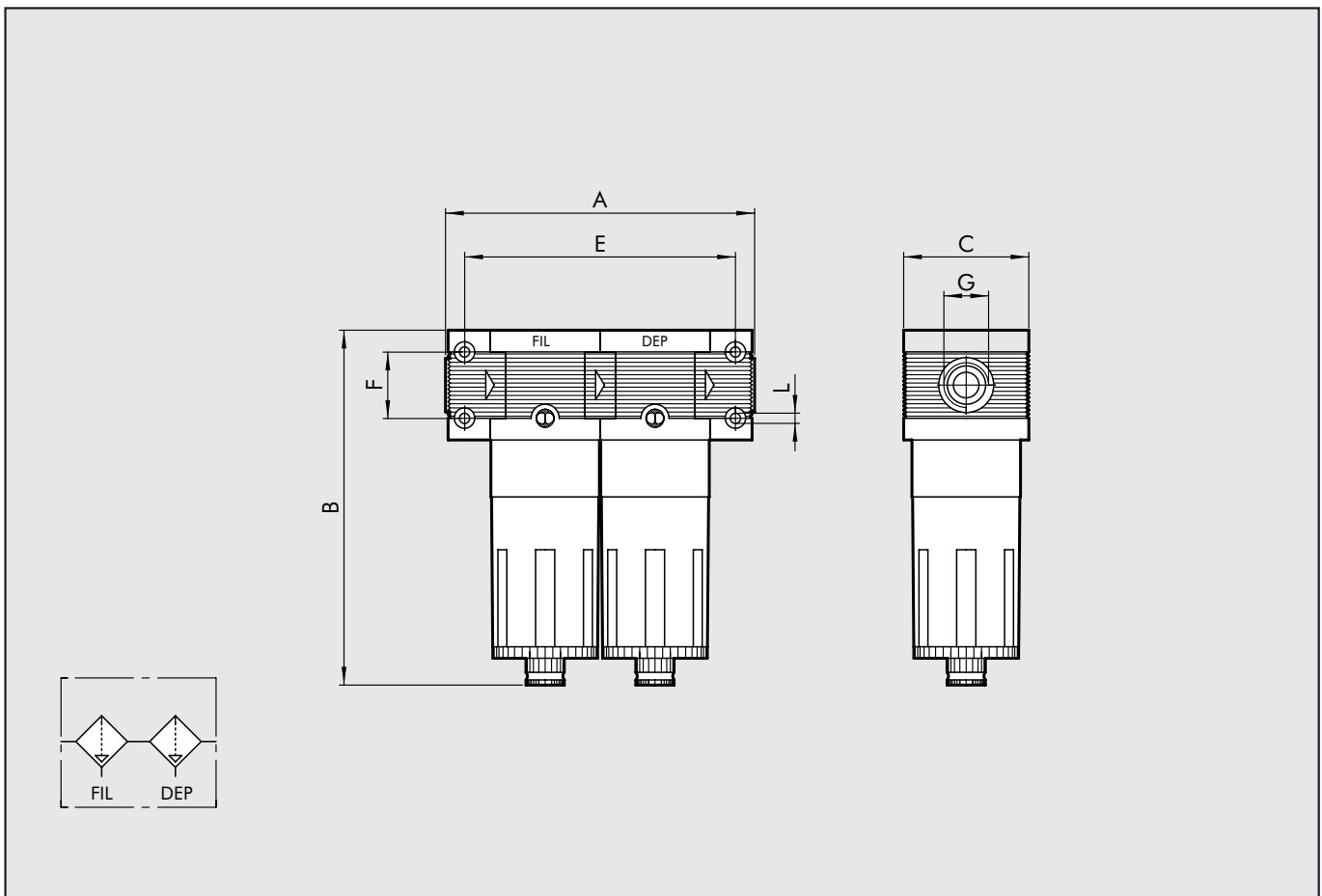

FIL+DEP Skillair® 400

TECHNICAL DATA		F+D 400			
Threaded port		G1"	G1"1/4"	G1"1/2"	G2"
Degree of filtration		Filter: 5µm - Depurator: 0.01µm			
Max. inlet pressure	MPa	1.3			
	bar	13			
	psi	188			
Maximum suggested flow rate		Please look at the flow rate curves at page 3.1/35			
Fluid		Compressed air			
Max temperature	°C	50			
at 10 bar	°F	122			
Weight	Kg	7~			
Wall fixing screws		M6x110			
Mounting		Vertical			
Bowl capacity	cm³	270			
Note on use		The end plates in the 400 series have a patented system with a rotary and sliding end joint to adapt the unit perfectly to the pipe cutting distance. The maximum inlet pressure for the version with RA automatic condensate drainage must not exceed 10 bar.			



DIMENSIONS		FIL+DEP 400			
THREADED PORT G		G1"	G1"1/4"	G1"1/2"	G2"
A		330-360		320	388-418
B		320			
C		116			
E		247			
F		80			
L		M6 hole			

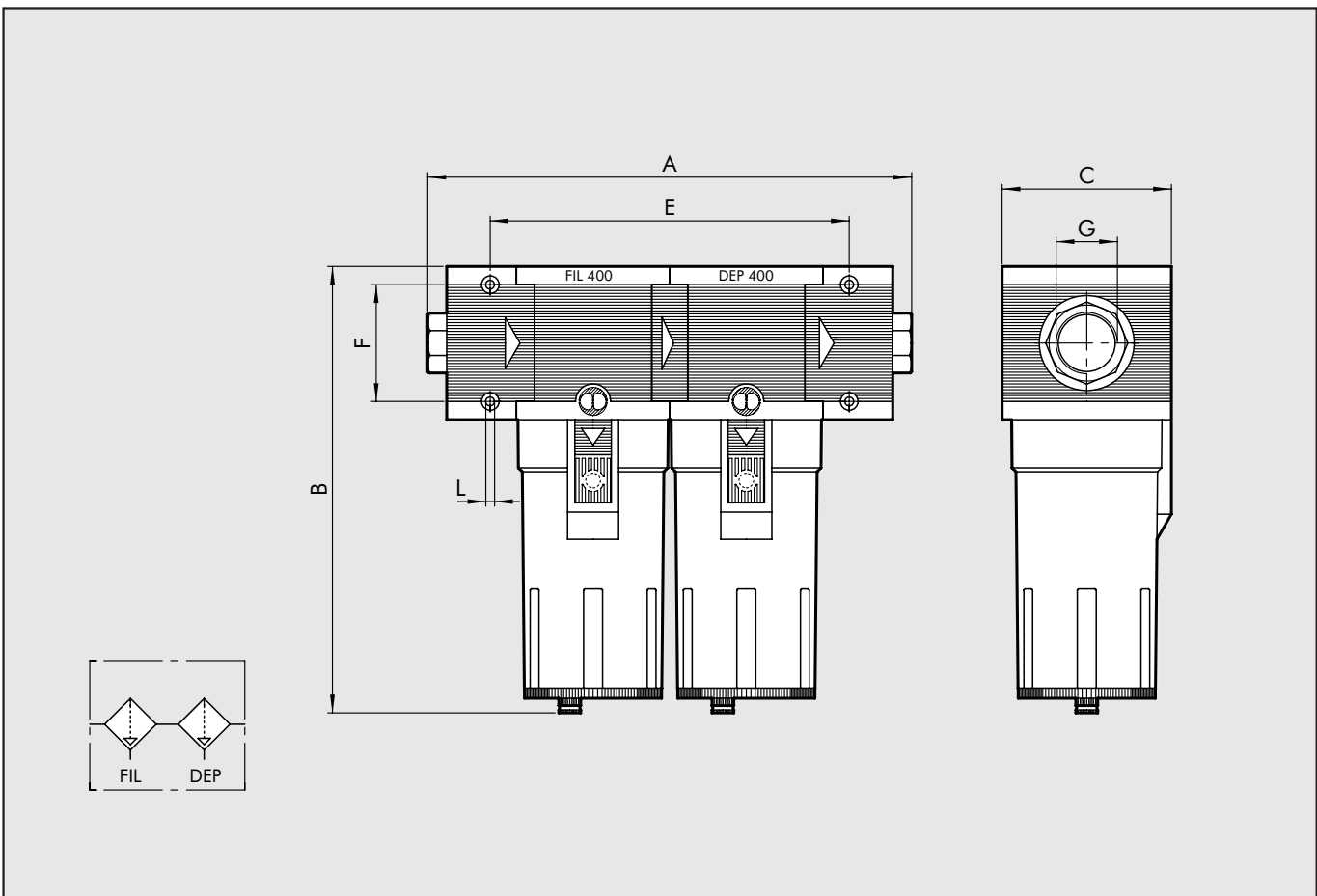

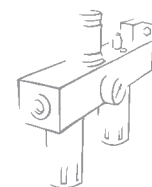

KEY TO CODES

F+D	100	1/4	5μm	RMSA	
ELEMENT	SIZE	THREADED PORT	DEGREE OF FILTRATION	TYPE OF CONDENSATE DRAIN	
F+D	100	1/4	5μm	RMSA SAC	
		3/8			
		1/4			RMSA RA
		3/8			
	1/2				
	1/2				
	300	1/2			
	3/4				
	1				
	1				
	400	1 1/4			
		1 1/2			
		2			
		2			

RMSA: Manual/semi-auto drain
SAC: Automatic drain for sizes 100 and 200. Operates by depression – requires variable air take-offs.
RA: Automatic drain for size 300 and 400. Float-type operation irrespective of the pressure and flow rate.

ORDERING CODES

Code	Description		
3289001	F+D 100 1/4 5 RMSA-RMSA		
3289005	F+D 100 1/4 5 SAC-RMSA		
3289006	F+D 100 1/4 5 SAC-SAC		
3389001	F+D 100 3/8 5 RMSA-RMSA		
3389005	F+D 100 3/8 5 SAC-RMSA		
3389006	F+D 100 3/8 5 SAC-SAC		
3489001	F+D 200 1/4 5 RMSA-RMSA		
3489005	F+D 200 1/4 5 SAC-RMSA		
3489006	F+D 200 1/4 5 SAC-SAC		
3589001	F+D 200 3/8 5 RMSA-RMSA		
3589005	F+D 200 3/8 5 SAC-RMSA		
3589006	F+D 200 3/8 5 SAC-SAC		
3689001	F+D 200 1/2 5 RMSA-RMSA		
3689005	F+D 200 1/2 5 SAC-RMSA		
3689006	F+D 200 1/2 5 SAC-SAC		
4489001	F+D 300 1/2 5 RMSA-RMSA		
4489002	F+D 300 1/2 5 RA-RA		
4589001	F+D 300 3/4 5 RMSA-RMSA		
4589002	F+D 300 3/4 5 RA-RA		
4689001	F+D 300 1 5 RMSA-RMSA		
4689002	F+D 300 1 5 RA-RA		
6189001	F+D 400 1 5 RMSA-RMSA		
6189002	F+D 400 1 5 RA-RA		
6289001	F+D 400 1 1/4 5 RMSA-RMSA		
6289002	F+D 400 1 1/4 5 RA-RA		
6389001	F+D 400 1 1/2 5 RMSA-RMSA		
6389002	F+D 400 1 1/2 5 RA-RA		
6489001	F+D 400 2 5 RMSA-RMSA		
6489002	F+D 400 2 5 RA-RA		

NOTES
