

Humphrey[®]



Balanced Valve Series

Multi-Purpose Direct-Acting Solenoid Valves



www.humphrey-products.com

A privately owned US company since 1901.

Humphrey Products Company • P.O. Box 2008 • Kalamazoo, MI 49003 USA
P.269.381.5500 • F.269.381.4113

BVS-2015 Copyright © 2015 Humphrey Products Company, Inc. Printed in U.S.A.

Balanced Valve Series



154
DIN-TYPE

Humphrey presents the **BALANCED VALVE** family, our next generation technology of balanced poppet, direct-acting solenoid valves. The versatile 3- and 4-port line up is available in three sizes, addressing a multitude of pneumatic applications.

MULTI-PURPOSE

See porting diagrams below. Valves work equally well through full pressure range of vacuum to 125 PSIG.

MULTI-MEDIA

Valves perform whether media is clean, dry or lubricated air, inert gas, or when airline impurities are present.

RELIABLE SHIFT, TIGHT SEAL

Shifting forces of the coil and return spring are optimized, seals poppet to our tight leakage specification.

FEATURES

- Small Size – 15mm, 19mm and 25mm width
- High Flow Capacity – from 0.15 to 1.2 Cv
- Light weight, low mass
- Versatile porting (See diagrams below.)
- Long service life
- Impervious to media conditions
- Low Leakage – maximum 4ccm @100 PSIG
- No lubrication required
- Unaffected by pressure fluctuations
- RoHS compliant materials

HIGH FLOW CAPACITY

Internal flow path management has been maximized. Excellent flow achieved within a reduced overall size.

EASE OF USE

Media isolated from solenoid. Electric and pneumatic connections on opposing surfaces ... reduces total space, simplifies mounting and connectivity.

BALANCED POPPET CONSTRUCTION

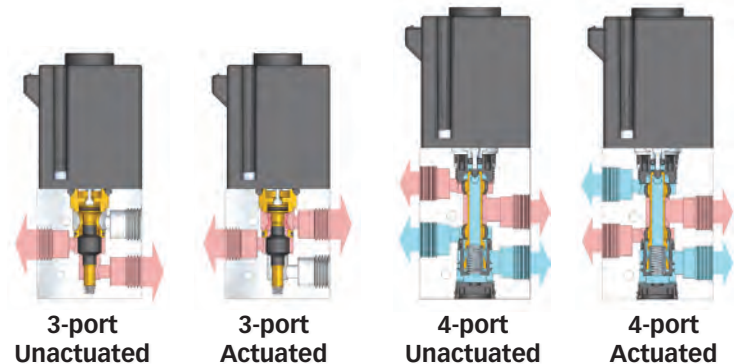

PORTING DIAGRAMS - 3-PORT

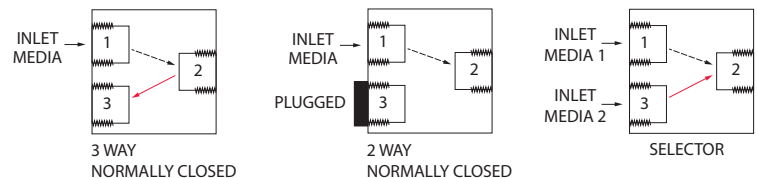

PORTING DIAGRAMS - 4-PORT

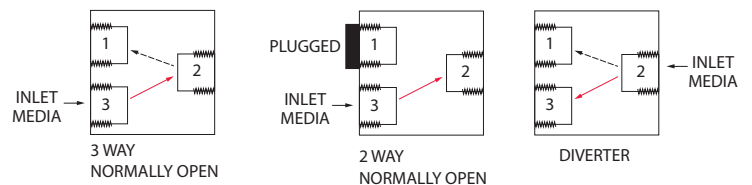
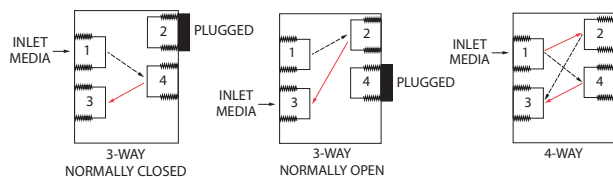

Black line indicates actuated flow path; Red line indicates unactuated flow path.

Balanced Valve Series

- In-line or Manifold Mount
- Optional non-locking manual override
- 12VDC, 24VDC or 120VAC
- Lead wire (w/plug-in: 15mm and 19mm valves) or mini DIN electrical entry
- Multi-purpose function

153 AND 154: SMALL BALANCED VALVE

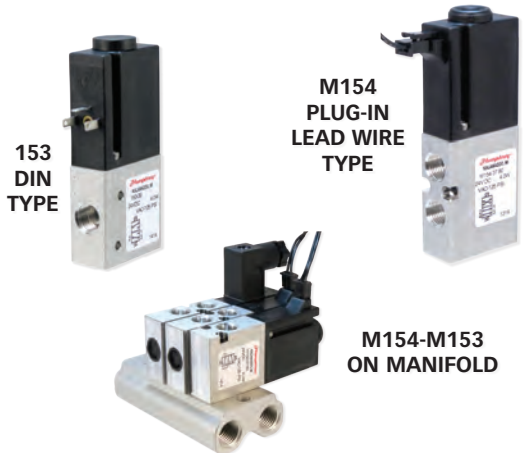

- Compact – 15mm valve width
- 1/8 PIPE ports
- Excellent flow –
 - *3-port 153: 15 scfm @100 PSIG
 - *4-port 154: 10 scfm @100 PSIG
- 4 watt Power Consumption

193 AND 194: MID-SIZE BALANCED VALVE



- Compact – 19mm valve width
- 1/4 PIPE ports
- Excellent flow –
 - *3-port 193: 38 scfm @100 PSIG
 - *4-port 194: 28 scfm @100 PSIG
- 6 watt Power Consumption

253 AND 254: LARGE BALANCED VALVE



- Compact – 25mm valve width
- 3/8 PIPE ports
- Excellent flow –
 - *3-port 253: 72 scfm @100 PSIG
 - *4-port 254: 68 scfm @100 PSIG
- 8 watt Power Consumption

Balanced Valve Series Specifications

MECHANICAL SPECIFICATIONS	153	154	193	194	253	254
Type of Operation	Direct Solenoid					
Function	Multi-Purpose					
Number of Ports	3	4	3	4	3	4
Port Size	1/8 PIPE		1/4 PIPE		3/8 PIPE	
Override	No override – standard. Non-Locking – option.					
Media	Air (Dry or Lubricated), Inert Gases, Vacuum					
Pressure Range	Vacuum to 125 PSIG					
Ambient Temperature Range	32° to 125°F (0° to 50°C)					
Flow @100 PSIG scfm (Cv)	15 (0.25)	10 (0.16)	38 (0.65)	28 (0.47)	72 (1.20)	68 (1.12)
Max Leakage (@100 PSIG)	4ccm					
Lubrication	Not required					
Filtration	40 micron, recommended					
Weight - lbs	0.2	0.22	0.4	0.44	0.7	0.8
Wetted Materials	Brass, Buna, Aluminum, SST					

ELECTRICAL SPECIFICATIONS	153	154	193	194	253	254
Standard Voltages	12VDC, 24VDC, 120/50/60					
Electrical Entry	Plug-In w/12" Lead Wire, DIN				Lead Wire, DIN	
Voltage Tolerance	±10% of rated voltage					
Coil Temperature Rise	90°F (50°C)		93°F (52°C)		102°F (57°C)	
Response Time (On/Off)	12/6 (8/35)	20/6 (20/32)	15/8 (22/44)	21/5 (21/27)	28/11 (28/44)	34/5 (34/17)
Power Consumption	4w / 5.2w		6w / 7.7w		8w / 9.8w	
Insulation	Class B					

AC SCHEMATIC

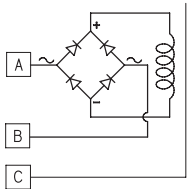

DC SCHEMATIC

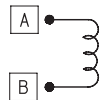

DC DIN SCHEMATIC

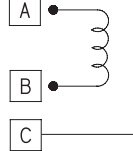

254 W/LEAD WIRES



M253-M254 DIN TYPE W/HS2 ON MANIFOLD



194 DIN TYPE

How to Order

Order Examples: 153-37-80-12VDC; 193-39-24VDC; 254-38-80-12VDC

VALVE MODEL	ELECTRICAL ENTRY			OVERRIDE CHOICES		LONG LEAD LENGTH		ROTATED COIL OPTION		VOLTAGE*
	Plug-In w/12" Leads	24" Lead Wires	DIN Connector	No Override	Non-Locking	Std. (12") Length	72" Length	Std. Position	Rotate 180°	
153 or M153	-37	Not Available	-39	(std)	-80	(std)	-LL	(std)	-RC	12VDC 24VDC 120/50/60*
154 or M154										
193 or M193										
194 or M194										
253 or M253	Not Available	-38								
254 or M254										

* 120/50/60 voltage available in DIN-type, code 39 only.

MANIFOLD	15MM*	19MM*	25MM*
2 STN	150M2	190M2	250M2
4 STN	150M4	190M4	250M4
6 STN	150M6	190M6	250M6
8 STN	150M8	190M8	250M8

* 15MM – for M153 and M154 valves
19MM – for M193 and M194 valves
25MM – for M253 and M254 valves

153/154 Small Balanced Valves

153 Schematic and Dimensional Drawings

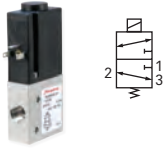

153 DIN TYPE

Plug-In with 12" Lead Wires

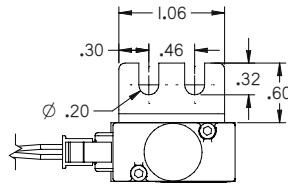

With Override (Code 80)

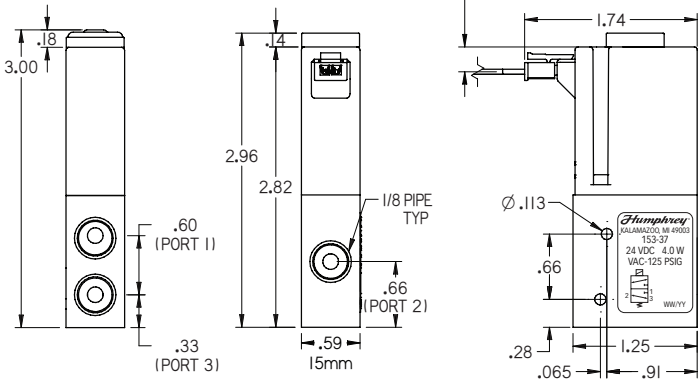

(M)153/(M)154 DIN with HS2 Connection

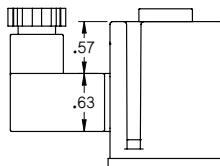
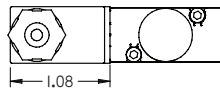

154 Schematic and Dimensional Drawings

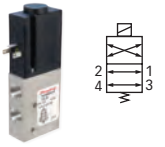

154 DIN TYPE

Plug-In with 12" Lead Wires

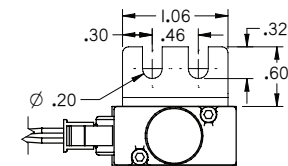

With Override (Code 80)

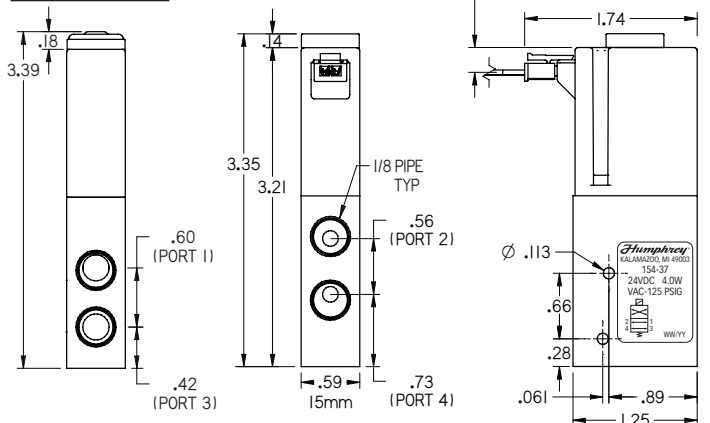

M153 PLUG-IN LEAD WIRE TYPE ON MANIFOLD



M154 DIN TYPE W/HS2 ON MANIFOLD

150M Manifold Dimensional Drawings

TOP VIEW

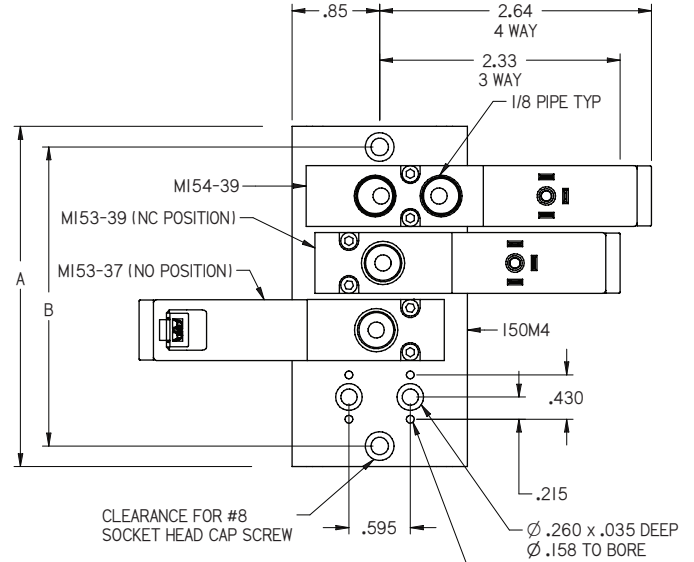

150M

No. of Stations	A	B
2	2.00	1.60
4	3.30	2.90
6	4.60	4.20
8	5.90	5.50

FRONT VIEW

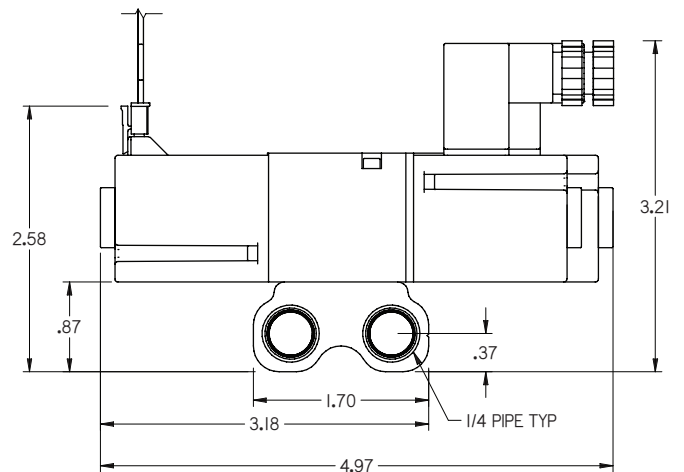

193/194 Mid-Size Balanced Valves

193 Schematic and Dimensional Drawings

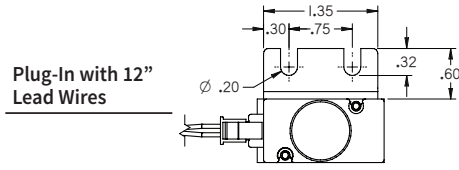

With Override (Code 80)

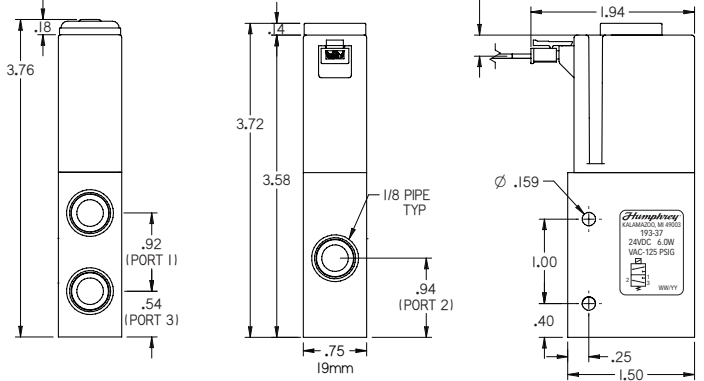

(M)193/(M)194 DIN with HS2 Connection

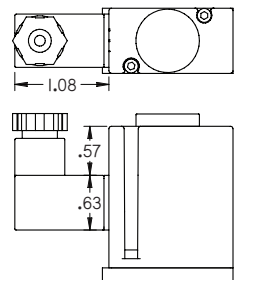

194 Schematic and Dimensional Drawings

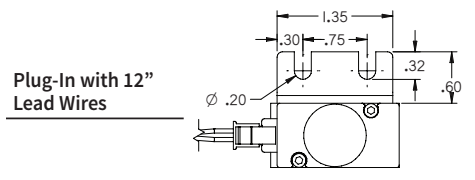

With Override (Code 80)

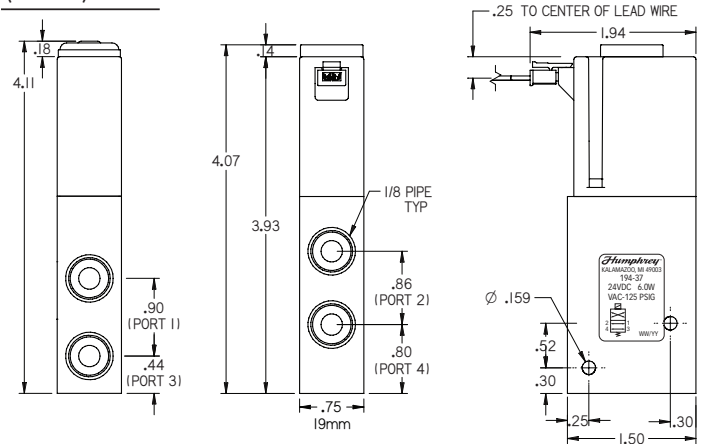

190M Manifold Dimensional Drawings

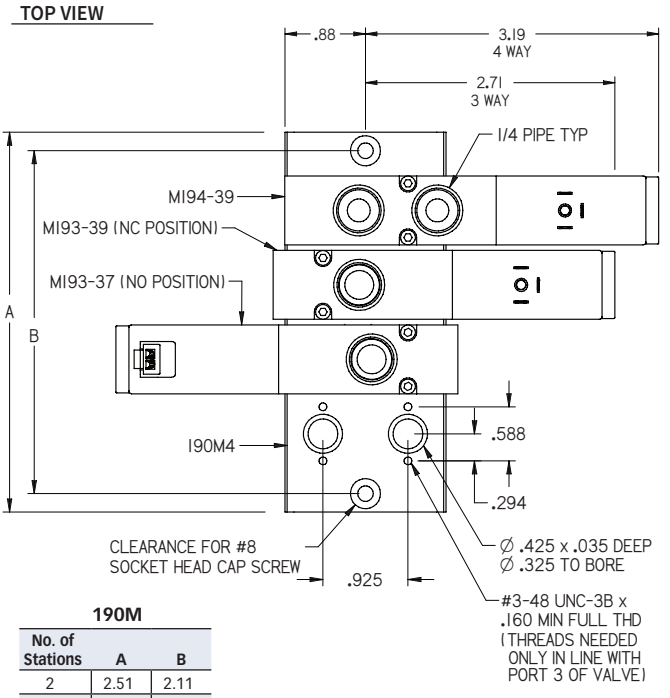

190M

No. of Stations	A	B
2	2.51	2.11
4	4.13	3.73
6	5.75	5.35
8	7.37	6.97

FRONT VIEW

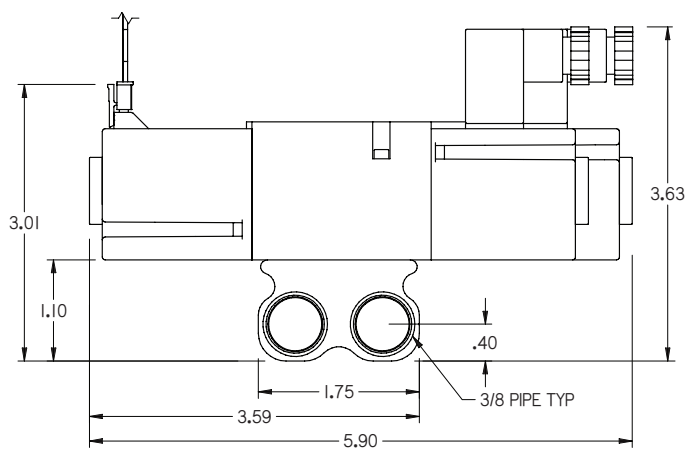

253/254 Large Balanced Valves

253 Schematic and Dimensional Drawings

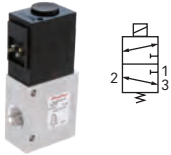

253 DIN TYPE

Plug-In with 24" Lead Wires

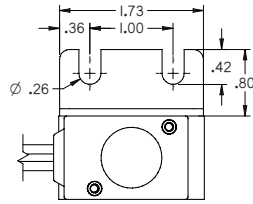

With Override (Code 80)

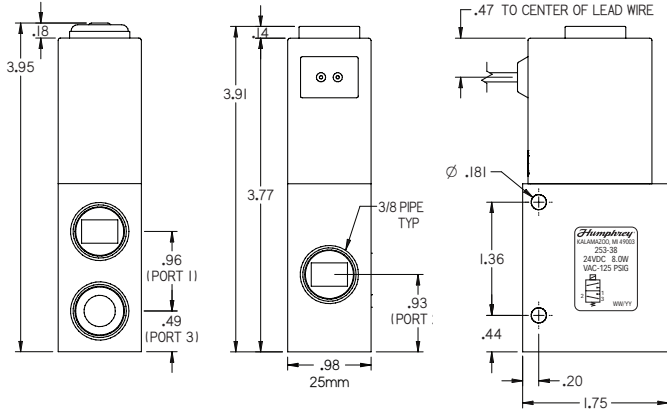

(M)253/(M)254 DIN with HS2 Connection

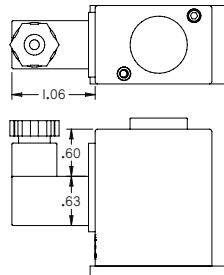

254 Schematic and Dimensional Drawings

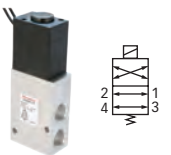

254 W/LEAD WIRES

Plug-In with 24" Lead Wires

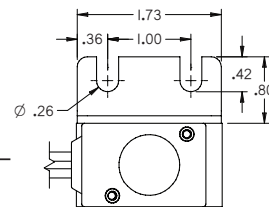

With Override (Code 80)

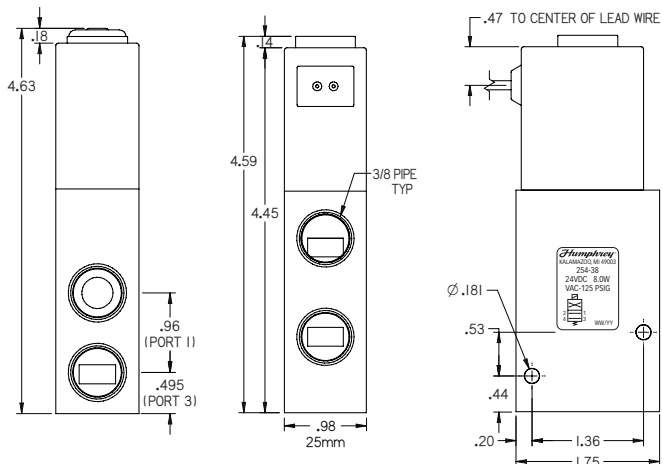

M253-M254 DIN TYPE W/HS2 ON MANIFOLD

250M Manifold Dimensional Drawings

TOP VIEW

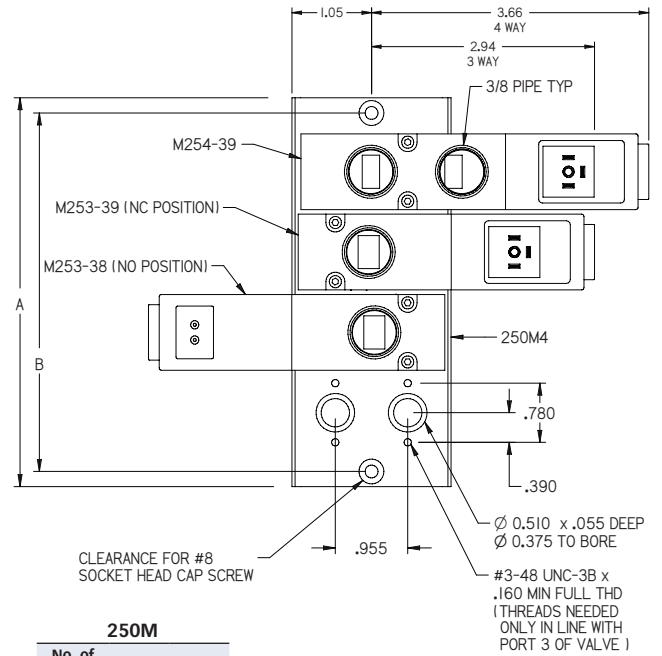

250M

No. of Stations	A	B
2	3.01	2.61
4	5.13	4.73
6	7.25	6.85
8	9.37	8.97

FRONT VIEW

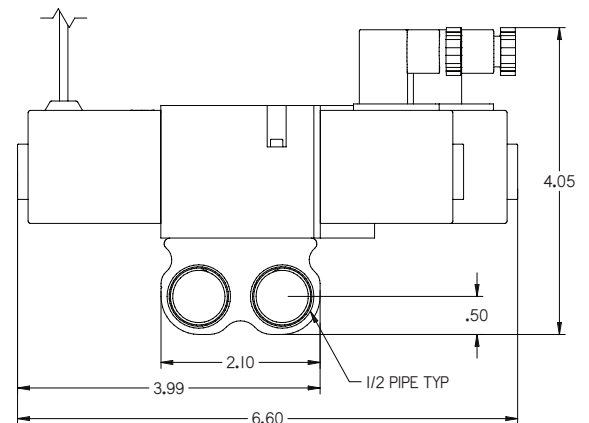

Valve Accessories

SERIES	153/154	193/194	253/254	NOTES
Description	Ordering Model Number			
Valve Mounting Bracket	46706	47226	8-388A	L-type bracket for inline valve mounting.
Pipe Plug	130-31	130-15	130-25	Plug 3-port valve for 2-way use. Plug 4-port for 3-way use.
Wire Connector with 12" lead	46669		N/A	Receptacle choices for plug-in electrical entry valves (valve option code 37).
Wire Connector with 72" lead	43200		N/A	
DIN Receptacle	HS2			Receptacle choices for DIN electrical entry valves (valve option code 39). Connector: DIN 43650C 15mm Style Receptacle (Micro Mini 9mm)
12VDC DIN Receptacle w/LED	HS2-LED-12V			
24VDC DIN Receptacle w/LED	HS2-LED-24V			
120VAC DIN Receptacle w/LED	HS2-LED-120V			
DIN Receptacle w/2000mm cable	HS2-CLL			

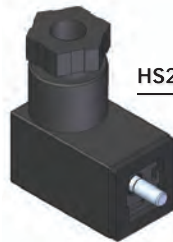
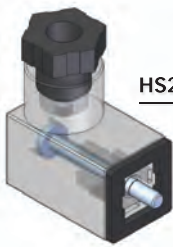
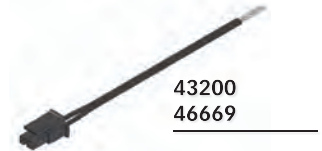
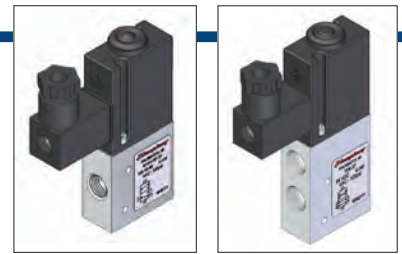

46706
47226
8-388A

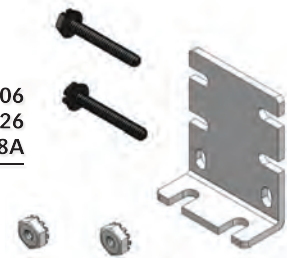

Manifold Accessories

SERIES	150M	190M	250M	NOTES
Description	Ordering Model Number			
Pipe Plug	130-15	130-25	130-21	For manifold supply and exhaust ports.
Block-Off Plate	46720	47222	47498	Includes plate, (2) O-rings, (2) screws
Valve Mounting Kit	46672	47221	47248	Includes (2) O-rings, (2) screws (replacement).
DIN Rail Clip	DRC			(2) clips, (2) screws. Mounts manifold to 35mm DIN Rail.
Plugging disc	46770	47224	47500	Bag of 10. Plugs 3-port valve for 2-way function. *

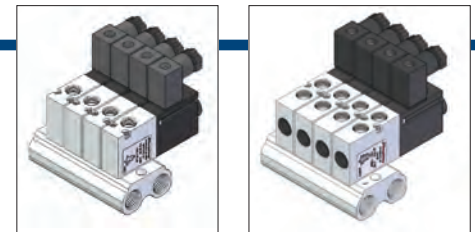

46720
47222
47498



* Place one disc between manifold and valve-to-manifold gasket, in exhaust path.

46770
47224
47500



130-15
130-25
130-21



46672
47221
47248

