

Selection diagram

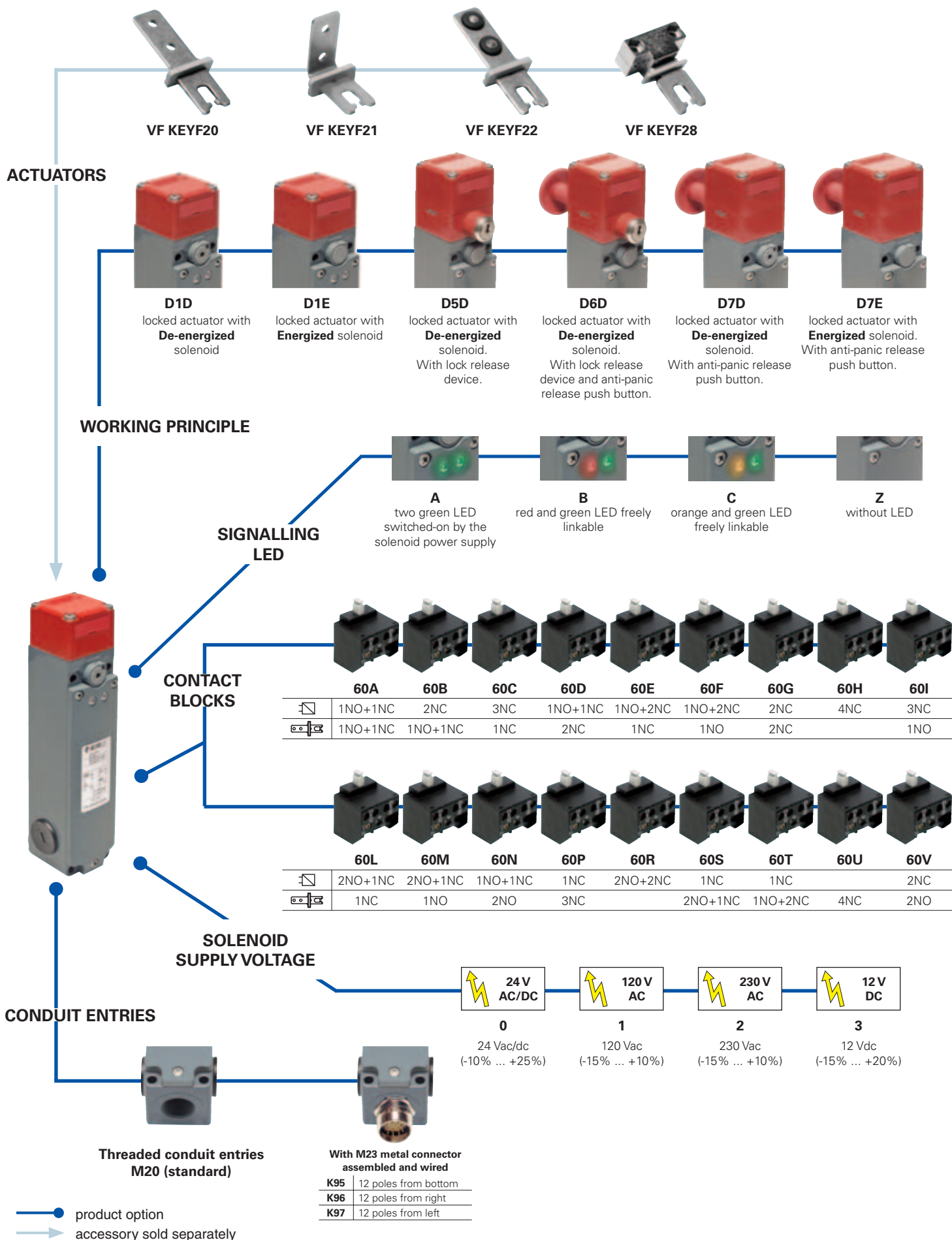



Code structure

Attention! The feasibility of a code number does not mean the effective availability of a product. Please contact our sales office.

article options FG 60AD1D0A-LP30F20GK95

Integrated contact blocks		
	Solenoid operated	Actuator operated
60A	1NO+1NC	1NO+1NC
60B	2NC	1NO+1NC
60C	3NC	1NC
60D	1NO+1NC	2NC
60E	1NO+2NC	1NC
60F	1NO+2NC	1NO
60G	2NC	2NC
60H	4NC	/
60I	3NC	1NO
60L	2NO+1NC	1NC
60M	2NO+1NC	1NO
60N	1NO+1NC	2NO
60P	1NC	3NC
60R	2NO+2NC	/
60S	1NC	1NC+2NO
60T	1NC	2NC+1NO
60U	/	4NC
60V	2NC	2NO

Working principle	
D1D	locked actuator with de-energized solenoid
D1E	locked actuator with energized solenoid
D5D	locked actuator with de-energized solenoid. With lock release device.
D6D	locked actuator with de-energized solenoid. With lock release device and anti-panic release push button.
D7D	locked actuator with de-energized solenoid. With anti-panic release push button.
D7E	locked actuator with energized solenoid. With anti-panic release push button.

Solenoid supply voltage	
0	24 Vac/DC (-10% ... +25%)
1	120 Vac (-15% ... +10%)
2	230 Vac (-15% ... +10%)
3	12 Vdc (-15% ... +20%)

Preinstalled connectors	
	no connectors (standard)
K95	with M23 metal connector assembled and wired, 12 poles from bottom
K96	with M23 metal connector assembled and wired, 12 poles from right
K97	with M23 metal connector assembled and wired, 12 poles from left

Contacts type	
	silver contacts (standard)
G	silver contacts gold plated 1 µm

Actuators	
	without actuator
F20	with straight actuator
F21	with right-angled actuator
F22	with actuator with rubber mountings
F28	with universal actuator

Release button length	
	Wall thickness length max 15 mm (standard)
LP30	Wall thickness length max 30 mm
LP40	Wall thickness length max 40 mm
LP60	Wall thickness length max 60 mm
LPRG	Adjustable for wall thickness length from 60 mm to 500 mm

Signalling LED	
A	two green LED switched-on by the solenoid power supply
B	red and green LED freely linkable
C	orange and green LED freely linkable
Z	without LED

1
1A
1B
2
2A
2B
2C
2D
2E
3
3A
3B
3C
4
4A
4B
4C
4D
4E
4F
4G
4H
5
6



Patent pending

Main features

- Actuator holding force 2500 N
- 10 contact blocks with 4 contacts
- Metal housing, three conduit entries M20
- Protection degree IP67
- Version with lock release device and emergency release push button
- 4 stainless steel actuators
- Rotating head and devices and not detachable
- Signalling LED
- Working with energized or de-energized solenoid

Markings and quality marks:

Approval IMQ: CA02.03848
Approval UL: E131787

Housing

Metal housing, coated with baked epoxy powder.

Three conduit entries M20

Protection degree: IP67 according to EN 60529
(electrical contacts)

General data

Safety parameters: see page 6/32
Ambient temperature: from -25°C to +60°C
Max operating frequency: 600 operations cycles¹/hour
Mechanical endurance: 1 million of operations cycles¹
Max actuating speed: 0,5 m/s
Min. actuating speed: 1 mm/s
Max holding force: 2500 N
Maximum force before the breaking in accordance with GS-ET-19: 2800 N
Maximum holding force in accordance with GS-ET-19: 2150 N
Max backlash of the actuator: 4,5 mm
Actuator extraction force: 30 N
Driving torque for installation: see pages 6/1-6/10

(1) One operation cycle means two movements, one to close and one to open contacts, as foreseen by EN 60947-5-1 standard..

Cross section of the conductors (flexible copper wire)

Contact blocks: min. 1 x 0,34 mm² (1 x AWG 22)
max. 2 x 1,5 mm² (2 x AWG 16)

In conformity with standards:

IEC 60947-5-1, EN 60947-5-1, IEC 60204-1, EN 60204-1, EN 1088, EN ISO 12100-1, EN ISO 12100-2, IEC 60529, EN 60529, EN 61000-6-2, EN 61000-6-3, NFC 63-140, VDE 0660-200, VDE 0113, CENELEC EN 50013, BG-GS-ET-15.

Approvals:

IEC 60947-5-1, UL 508

In conformity with requirements requested by:

Low Voltage Directive 2006/95/EC, Machinery Directive 2006/42/EC and Electromagnetic Compatibility 2004/108/EC.

Positive contact opening in conformity with standards:

IEC 60947-5-1, EN 60947-5-1, VDE 0660-206.

Solenoid

Solenoid duty cycle: 100% ED
Solenoid protection 12 V: fuse 1 A type gG
Solenoid protection 24 V: fuse 0,5 A type gG
Solenoid protection 120 V: fuse 315 mA, delayed type
Solenoid protection 230 V: fuse 315 mA, delayed type
Solenoid power: 9 VA

⚠ If not expressly indicated in this chapter, for the right installation and the correct utilization of all articles see requirements indicated from page 6/1 to page 6/10.

Electrical data**Utilization categories**

without connector

Thermal current (I_{th}): 10 A
Rated insulation voltage (U_i): 400 Vac 300 Vdc
Conditional short circuit current: 1000 A according to EN 60947-5-1
Protection against short circuits: fuse 10 A 500 V type gG
Pollution degree: 3

Alternate current: AC15 (50...60 Hz)
U_e (V) 120 250 400
I_e (A) 6 5 3
Direct current: DC13
U_e (V) 24 125 250
I_e (A) 3 0,7 0,4

with 12 poles M23 connector

Thermal current (I_{th}): 8 A
Rated insulation voltage (U_i): 250 Vac 300 Vdc
Protection against short circuits: fuse 8 A 500 V type gG
Pollution degree: 3

Alternate current: AC15 (50...60 Hz)
U_e (V) 120 250
I_e (A) 6 5
Direct current: DC13
U_e (V) 24 125 250
I_e (A) 3 0,7 0,4



Data type approved by IMQ

Rated insulation voltage (Ui): 400 Vac
Thermal current (Ith): 10 A
Protection against short circuits: fuse 10 A 500 V type aM
Protection degree: IP67
MV terminals (screw clamps)
Pollution degree 3
Utilization category: AC15
Operation voltage (Ue): 400 Vac (50 Hz)
Operation current (Ie): 3 A
Forms of the contact element: X+X+X+X, Y+Y+Y+Y, X+Y+Y+Y, X+X+Y+Y, X+X+X+Y
Positive opening of contacts on contact block 60A, 60B, 60C, 60D, 60E, 60F, 60G, 60H, 60I, 60L, 60M, 60N, 60P, 60R, 60S, 60T, 60U, 60V

In conformity with standards: EN 60947-1, EN 60947-5-1 and subsequent modifications and completions, fundamental requirements of the Low Voltage Directive 2006/95/CE and subsequent modifications and completions.

Please contact our technical service for the list of approved products.

Limits of utilization dirt may penetrate in any way into the head and deposit there, in particular where metal dust, concrete or chemicals are spread.

Do not use where explosive or inflammable gas is present.
Use ATEX products in environments with explosion hazard (see page 2/137)

Data type approved by UL

Utilization categories A300 (720 VA, 120-300 Vac)
Q300 (69 VA, 125-250 Vdc)

Data of the housing type 1, 4X "indoor use only"; 12, 13

In conformity with standard: UL 508

Please contact our technical service for the list of approved products.

1

1A

1B

2

2A

2B

2C

2D

2E

3

3A

3B

3C

4

4A

4B

4C

4D

4E

4F

4G

4H

5

6

Description

These switches are used on machines where the hazardous conditions remain for a while, even after the machines has been switched off, for example because of mechanical inertia of pulleys, saw disks, parts under pressure or with high temperatures. They can also be used when it is necessary to control machine guards allowing the opening of protections only under specific conditions.

Actuator holding force

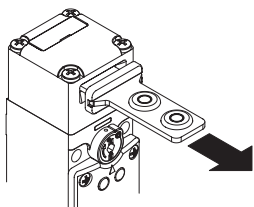

The strong interlocking system guarantees a maximum actuator holding force of 2500 N.

Actuating regulation zone

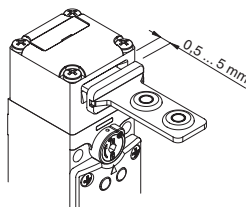

This switch has a wide backlash of the actuator into the head (4,5 mm) to avoid that door gaskets keep in traction the actuator on the solenoid. With closed door, check that the actuator doesn't knock straight against the head of the switch; it must be in the adjustment zone (0,5...5 mm)

Rotating heads and devices

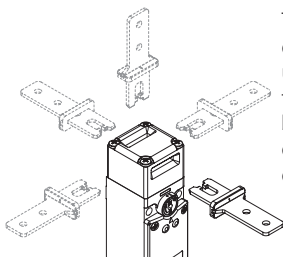

The head can be quickly rotated on each of the 4 sides of the switch by unfastening the four fixing screws. Also the lock release device and the release button can be rotated in 90° steps; this enables the switch to assume 32 different configurations.

4 poles contact block

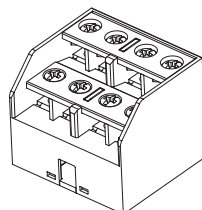

Innovative 4 poles contact block, available in different contacts configurations to monitor the actuator or the solenoid (patented). The contact block is supplied with no-loosening screws and self-lifting plates

Release device with rotating lock

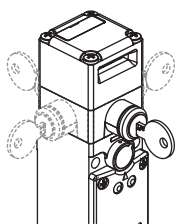

The auxiliary release device with rotating lock is used to allow the maintenance or the entry into the machinery to authorized personnel only. Rotating the key, will make the same action of the solenoid, that is move solenoid contacts and release the actuator. The device can be rotated allowing the installation of the safety switch inside the machinery and

making the release device accessible outside the protection. In this way, the switch is more protected against possible tampering and the external side/surface of the machinery remains pleasant.

Emergency release push button

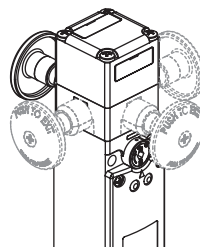

This device is used when the safety switch controls hazardous areas where operators may physically enter with all their body. The release button, oriented towards inside the machinery, allows the exit of the operator accidentally trapped also in case of possible black-out. Pushing the button, it will be actuated the same function of the auxiliary release device.

To reset the switch, restore the button to the initial position. The emergency button can be rotated, available with different lengths and it is fixed to the switch by a screw, so to allow the installation of the switch inside or outside the guards.

Lock release device and emergency push button

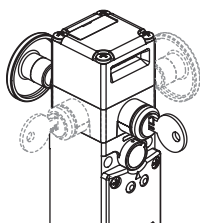

This device performs the two above mentioned functions at the same time. Also in this case the device can be rotated and the release button can be ordered with different lengths. The activation of the button has the priority on the lock, that is with the closed lock is possible to activate the button and unlock the switch. To reset the switch is

necessary to restore lock and button to their initial position.

Not detachable head and devices

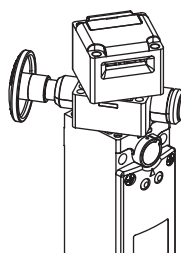

The head and the release devices can be rotated but they are not detachable to each other. In such a way the switch is safer because the installer do not have to worry about the assembly of various components and there is a lower probability of damages (loss of small parts, dirt penetration, etc.)

Signalling LED type A



In the version with signalling LED type A, two green LED are switched-on directly by the solenoid power supply. Wiring is not necessary.

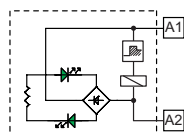

Signalling LED type B



In the version with signalling LED type B, two LED connection wires are available, one green and one red. Through suitable connections to the contact block, it is possible to control the different states of the switch.

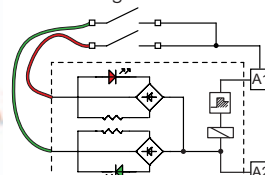



Description



Working conditions

The working principle of these safety switches allows three different working states:

state A: with the actuator inserted and blocked by the solenoid

state B: with the actuator inserted but not blocked

state C: with the actuator extracted

All or some of these states may be controlled through the positive opening contacts of the internal contact block. In detail, contact blocks that have electric contacts marked with the symbol of the solenoid () are switched in the transition between the state A and state B, while the electric contacts marked with the symbol of the actuator () are switched between state B and state C:

Working principle

It is also possible to choose between two working principles for the actuator locking:

- **Working principle D**: Actuator blocked with de-energized solenoid. Actuator release is obtained by power supply to the solenoid (see example of working cycle steps).
- **Working principle E**: Actuator blocked with energized solenoid. The unlock of the actuator is obtained by power-off to the solenoid. It is advisable to use this version under special conditions because a blackout will allow the immediate opening of the protection.

Product versatility

This series of products includes many technical solutions that results in easier installation and working:

- Four different types of stainless steel actuators, suitable to be fixed in several positions and with insertion radius arc equal to or over 80 mm.
- Swinging head, in 90° steps, with two actuator entries for easy installation of the switch. Heads D5, D6 and D7 are provided with release devices that can be rotated independently to the actuator entry side. All parts of heads are rotating but not detachable from the body, in order to avoid any tampering or wrong assembling during the installation.
- To extract the inserted but not blocked actuator, a 30 N force is necessary, that avoids the guard opening because of vibrations or impacts.
- Extremely heavy mechanical system of actuator locking, able to support traction forces up to 2500 N.
- When actuator is locked, it can still move a little (4,5 mm), to avoid that door gaskets keep in traction the actuator on the solenoid.
- Housing with three conduit entries for an easier installation or connection in series.
- Electronic control of the power supply, which allow a wide tolerance on supply voltage. This technical solution resolves the problems that may derive from not stable power supply (machine distance from main transformers, tension variation between night/day hours), allowing also a low solenoid power consumption and consequently enlarging the working temperatures range of the switch.
- No-loosing screws contact blocks, fingers protection, contacts with double interruption, high contact reliability.
- Version with signalling LED connected to the power supply or freely linked by the installer. LED are externally visible through the housing cover.

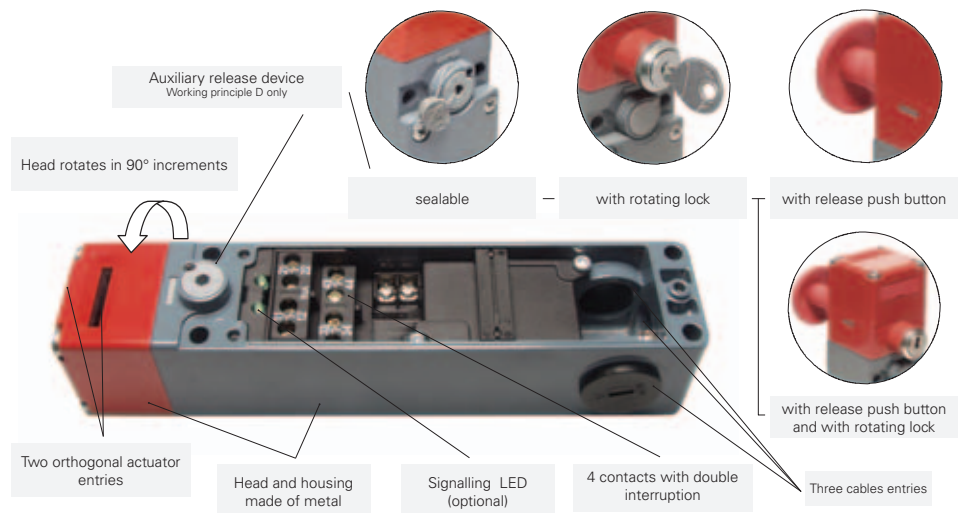

Release device

Versions with D working principle are supplied with a sealable auxiliary release device used by technicians during the installation or to access the machine in case of black-out.

Head D1: • The auxiliary release device is actuated by screwing to the end the safety dowel and rotating the device by 180°.

- The arrow on the switch cover indicates the auxiliary release device state. After the actuator release, put in the start position and reposition the safety dowel.
- To avoid improper use of the auxiliary release device during the usual machine working cycle, it has to be sealed with some drops of paint or by lead sealing.

Head D5: The auxiliary release device is composed of a lock with double key supplied on issue.

Head D7: The auxiliary release device is composed of a mushroom-head push button with no panic functions. This device must be rotated towards the inner and dangerous side of the machine so that an operator entrapped could activate it, release the switch and go out of the area. To restore the switch, reset the push button. This device cannot be used for functions of emergency stop of the machine.

Head D6: This head has contemporaneously functions of heads D5 and D7. The release occurs always, any of two devices is activated (push button or lock).

Gate monitoring

These switches alone cannot protect operators or maintenance men where they may physically enter with all their body in the hazardous area, because an involuntary closing of the protection behind them could allow the restart of the machine. If the authorization to the machine restart is completely granted by these switches, it must be foresee a system to avoid that risk, as for example the pad lockable device to lock the actuator entry, item VF KB2 at page 4/70 or a safety handle with padlocks as for example VF AP-P11B-200P (page 4/93).

1
1A
1B
2
2A
2B
2C
2D
2E
3
3A
3B
3C
4
4A
4B
4C
4D
4E
4F
4G
4H
5
6

Example of working cycle steps with FG 60AD1D0A-F21 (switch with working principle D)

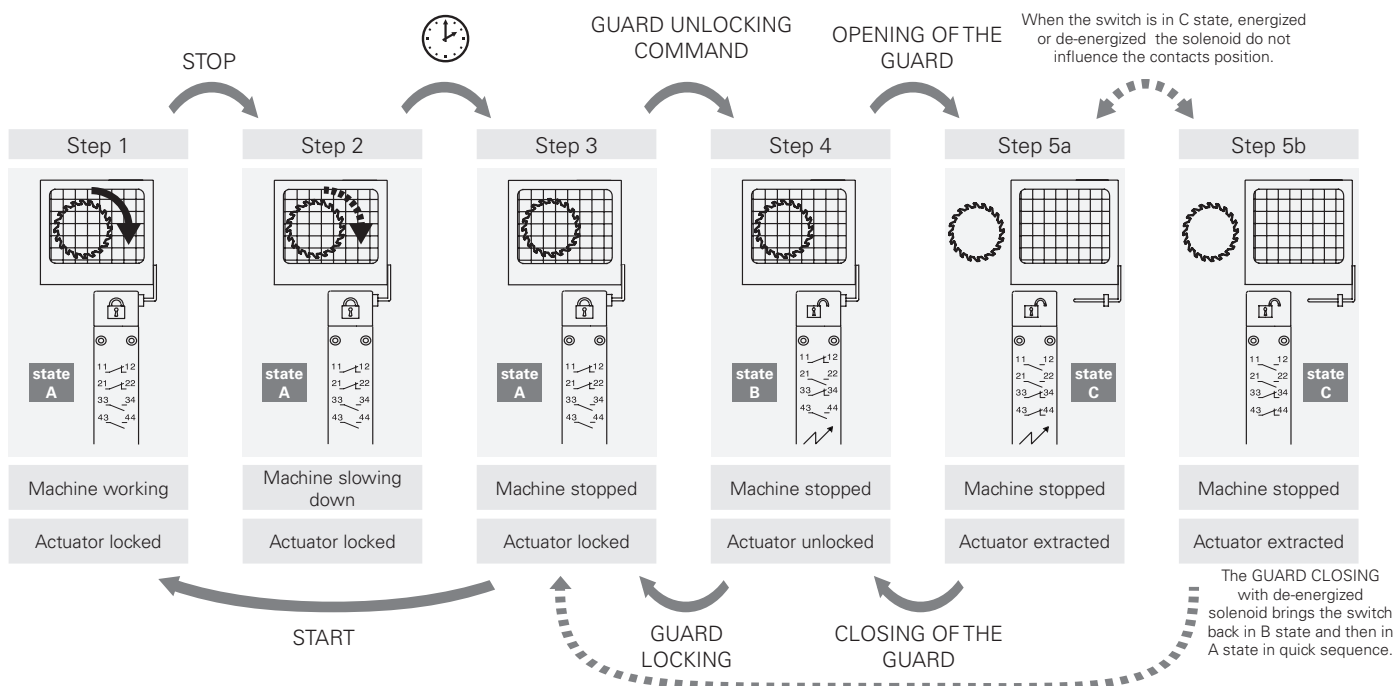

Application examples on machinery guards

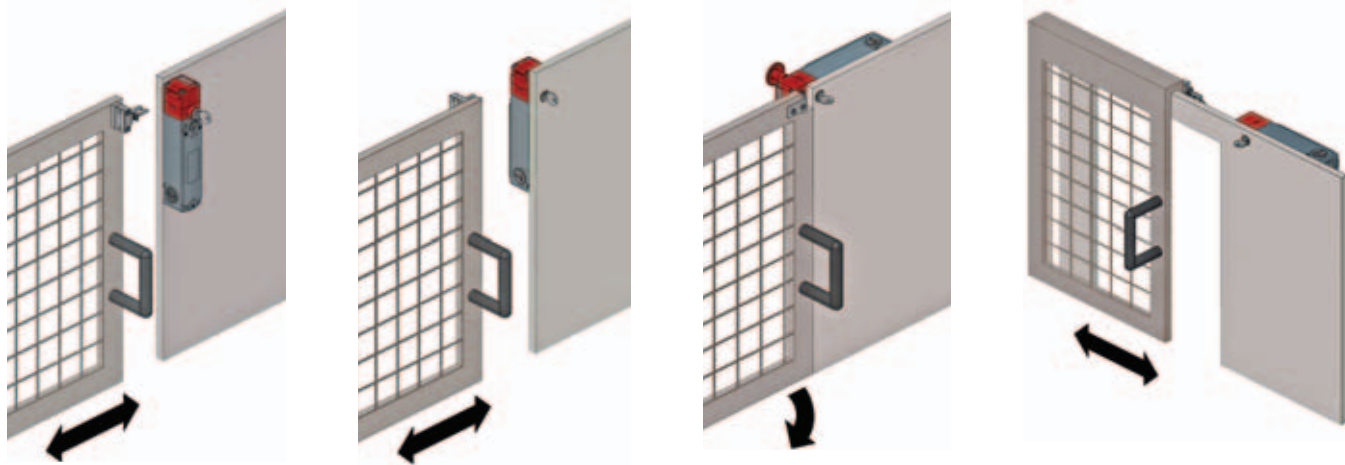

Dimensional drawings

Contacts type:

L = slow action

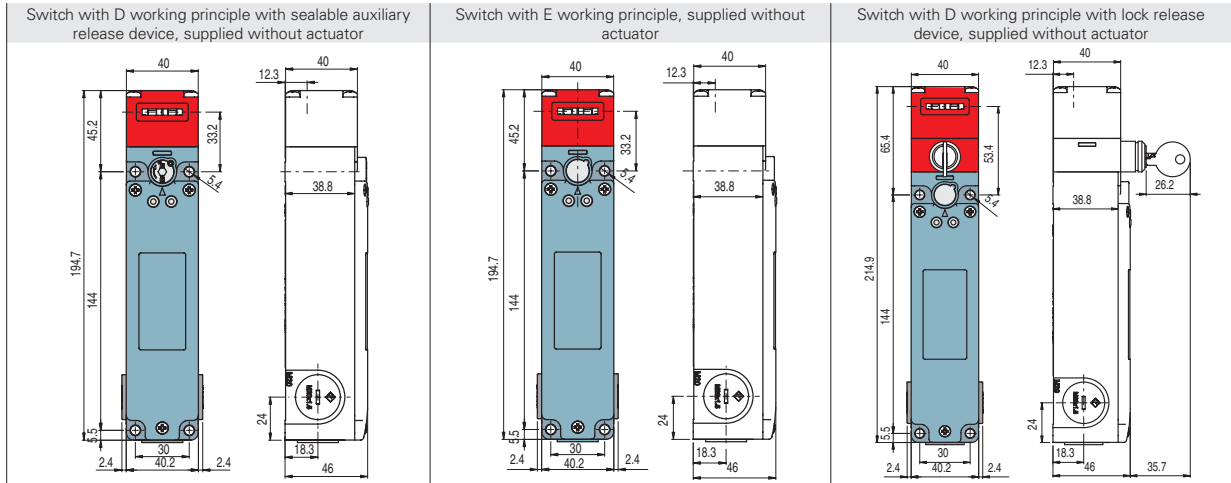

Contact blocks

		Switch with D working principle with sealable auxiliary release device, supplied without actuator	Switch with E working principle, supplied without actuator	Switch with D working principle with lock release device, supplied without actuator
60A	L	FG 60AD1D0A ⊕ 1NO+1NC 1NO+1NC	FG 60AD1E0A ⊕ 1NO+1NC 1NO+1NC	FG 60AD5D0A ⊕ 1NO+1NC 1NO+1NC
60B	L	FG 60BD1D0A ⊕ 2NC 1NO+1NC	FG 60BD1E0A ⊕ 2NC 1NO+1NC	FG 60BD5D0A ⊕ 2NC 1NO+1NC
60C	L	FG 60CD1D0A ⊕ 3NC 1NC	FG 60CD1E0A ⊕ 3NC 1NC	FG 60CD5D0A ⊕ 3NC 1NC
60D	L	FG 60DD1D0A ⊕ 1NO+1NC 2NC	FG 60DD1E0A ⊕ 1NO+1NC 2NC	FG 60DD5D0A ⊕ 1NO+1NC 2NC
60E	L	FG 60ED1D0A ⊕ 1NO+2NC 1NC	FG 60ED1E0A ⊕ 1NO+2NC 1NC	FG 60ED5D0A ⊕ 1NO+2NC 1NC
60F	L	FG 60FD1D0A ⊕ 1NO+2NC 1NO	FG 60FD1E0A ⊕ 1NO+2NC 1NO	FG 60FD5D0A ⊕ 1NO+2NC 1NO
60G	L	FG 60GD1D0A ⊕ 2NC 2NC	FG 60GD1E0A ⊕ 2NC 2NC	FG 60GD5D0A ⊕ 2NC 2NC
60H	L	FG 60HD1D0A ⊕ 4NC /	FG 60HD1E0A ⊕ 4NC /	FG 60HD5D0A ⊕ 4NC /
60I	L	FG 60ID1D0A ⊕ 3NC 1NO	FG 60ID1E0A ⊕ 3NC 1NO	FG 60ID5D0A ⊕ 3NC 1NO
60L	L	FG 60LD1D0A ⊕ 2NO+1NC 1NC	FG 60LD1E0A ⊕ 2NO+1NC 1NC	FG 60LD5D0A ⊕ 2NO+1NC 1NC
60M	L	FG 60MD1D0A ⊕ 2NO+1NC 1NO	FG 60MD1E0A ⊕ 2NO+1NC 1NO	FG 60MD5D0A ⊕ 2NO+1NC 1NO
60N	L	FG 60ND1D0A ⊕ 1NO+1NC 2NO	FG 60ND1E0A ⊕ 1NO+1NC 2NO	FG 60ND5D0A ⊕ 1NO+1NC 2NO
60P	L	FG 60PD1D0A ⊕ 1NC 3NC	FG 60PD1E0A ⊕ 1NC 3NC	FG 60PD5D0A ⊕ 1NC 3NC
60R	L	FG 60RD1D0A ⊕ 2NO+2NC /	FG 60RD1E0A ⊕ 2NO+2NC /	FG 60RD5D0A ⊕ 2NO+2NC /
60S	L	FG 60SD1D0A ⊕ 1NC 2NO+1NC	FG 60SD1E0A ⊕ 1NC 2NO+1NC	FG 60SD5D0A ⊕ 1NC 2NO+1NC
60T	L	FG 60TD1D0A ⊕ 1NC 1NO+2NC	FG 60TD1E0A ⊕ 1NC 1NO+2NC	FG 60TD5D0A ⊕ 1NC 1NO+2NC
60U	L	FG 60UD1D0A ⊕ 4NC	FG 60UD1E0A ⊕ 4NC	FG 60UD5D0A ⊕ 4NC
60V	L	FG 60VD1D0A ⊕ 2NC 2NO	FG 60VD1E0A ⊕ 2NC 2NO	FG 60VD5D0A ⊕ 2NC 2NO
Min. force		30 N (60 N ⊕)	30 N (60 N ⊕)	30 N (60 N ⊕)
Travel diagrams		page 4/68 - group 1	page 4/68 - group 1	page 4/68 - group 1

How to read travel diagrams

All measures in the diagrams are in mm

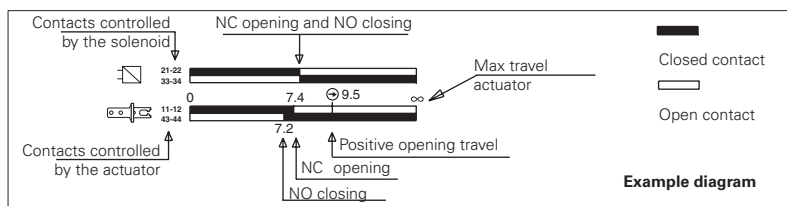

IMPORTANT:

NC contact has to be considered with inserted and locked actuator. In safety applications it is necessary to activate the switch at least up to the positive opening point indicated in the diagrams with the symbol ⊕. Operate the switch at least with the positive opening force, indicated between brackets, below each article, next the value of minimum force.



Contacts type:

L = slow action

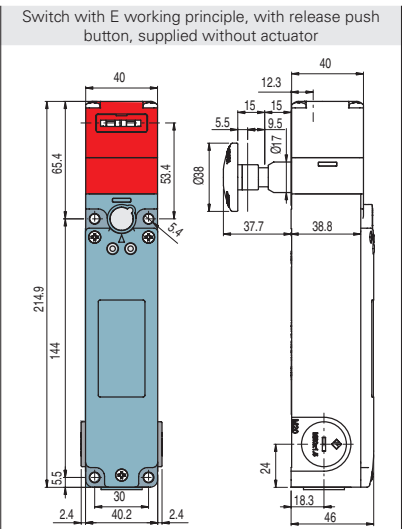
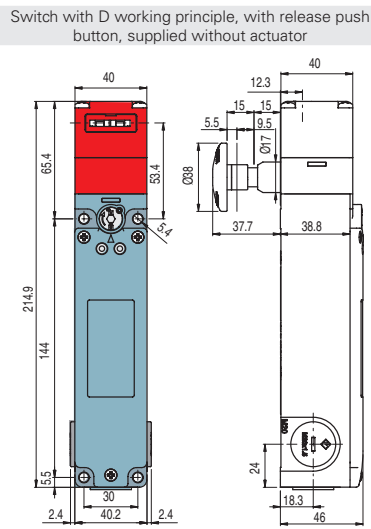
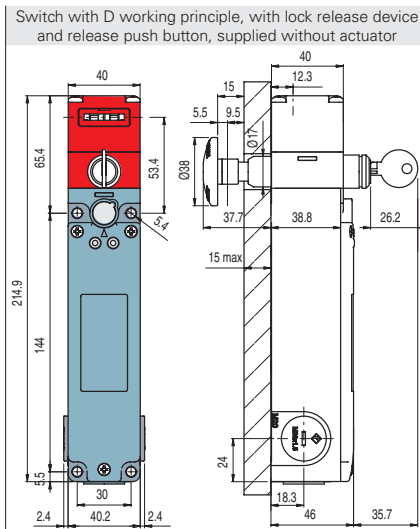

Contact blocks

60A	L	FG 60AD6D0A		1NO+1NC 1NO+1NC	FG 60AD7D0A		1NO+1NC 1NO+1NC	FG 60AD7E0A		1NO+1NC 1NO+1NC
60B	L	FG 60BD6D0A		2NC 1NO+1NC	FG 60BD7D0A		2NC 1NO+1NC	FG 60BD7E0A		2NC 1NO+1NC
60C	L	FG 60CD6D0A		3NC 1NC	FG 60CD7D0A		3NC 1NC	FG 60CD7E0A		3NC 1NC
60D	L	FG 60DD6D0A		1NO+1NC 2NC	FG 60DD7D0A		1NO+1NC 2NC	FG 60DD7E0A		1NO+1NC 2NC
60E	L	FG 60ED6D0A		1NO+2NC 1NC	FG 60ED7D0A		1NO+2NC 1NC	FG 60ED7E0A		1NO+2NC 1NC
60F	L	FG 60FD6D0A		1NO+2NC 1NO	FG 60FD7D0A		1NO+2NC 1NO	FG 60FD7E0A		1NO+2NC 1NO
60G	L	FG 60GD6D0A		2NC 2NC	FG 60GD7D0A		2NC 2NC	FG 60GD7E0A		2NC 2NC
60H	L	FG 60HD6D0A		4NC /	FG 60HD7D0A		4NC /	FG 60HD7E0A		4NC /
60I	L	FG 60ID6D0A		3NC 1NO	FG 60ID7D0A		3NC 1NO	FG 60ID7E0A		3NC 1NO
60L	L	FG 60LD6D0A		2NO+1NC 1NC	FG 60LD7D0A		2NO+1NC 1NC	FG 60LD7E0A		2NO+1NC 1NC
60M	L	FG 60MD6D0A		2NO+1NC 1NO	FG 60MD7D0A		2NO+1NC 1NO	FG 60MD7E0A		2NO+1NC 1NO
60N	L	FG 60ND6D0A		1NO+1NC 2NO	FG 60ND7D0A		1NO+1NC 2NO	FG 60ND7E0A		1NO+1NC 2NO
60P	L	FG 60PD6D0A		1NC 3NC	FG 60PD7D0A		1NC 3NC	FG 60PD7E0A		1NC 3NC
60R	L	FG 60RD6D0A		2NO+2NC /	FG 60RD7D0A		2NO+2NC /	FG 60RD7E0A		2NO+2NC /
60S	L	FG 60SD6D0A		1NC 2NO+1NC	FG 60SD7D0A		1NC 2NO+1NC	FG 60SD7E0A		1NC 2NO+1NC
60T	L	FG 60TD6D0A		1NC 1NO+2NC	FG 60TD7D0A		1NC 1NO+2NC	FG 60TD7E0A		1NC 1NO+2NC
60U	L	FG 60UD6D0A		4NC	FG 60UD7D0A		4NC	FG 60UD7E0A		4NC
60V	L	FG 60VD6D0A		2NC 2NO	FG 60VD7D0A		2NC 2NO	FG 60VD7E0A		2NC 2NO
Min. force		30 N (60 N		30 N (60 N		30 N (60 N				
Travel diagrams		page 4/68 - group 1		page 4/68 - group 1		page 4/68 - group 1				

Travel diagrams table

Contact blocks	Group 1	Contact blocks	Group 1	Contact blocks	Group 1
60A 2NO+2NC		60G 4NC		60P 4NC	
60B 1NO+3NC		60H 4NC		60R 2NO+2NC	
60C 4NC		60I 1NO+3NC		60S 2NO+2NC	
60D 1NO+3NC		60L 1NO+3NC		60T 1NO+3NC	
60E 1NO+3NC		60M 3NO+1NC		60U 4NC	
60F 2NO+2NC		60N 3NO+1NC		60V 2NO+2NC	

Items with code on the **green** background are available in stock

Stainless steel actuators

IMPORTANT: These actuators must be used with FG series only (e.g. FG 60AD1D0A)

Article	Description
VF KEYF20	Straight actuator

Article	Description
VF KEYF21	Right-angled actuator

Article	Description
VF KEYF22	Actuator with rubber mountings

Universal actuator VF KEYF28

IMPORTANT: These actuators must be used with FG series only (e.g. FG 60AD1D0A)

Article	Description
VF KEYF28	Universal actuator

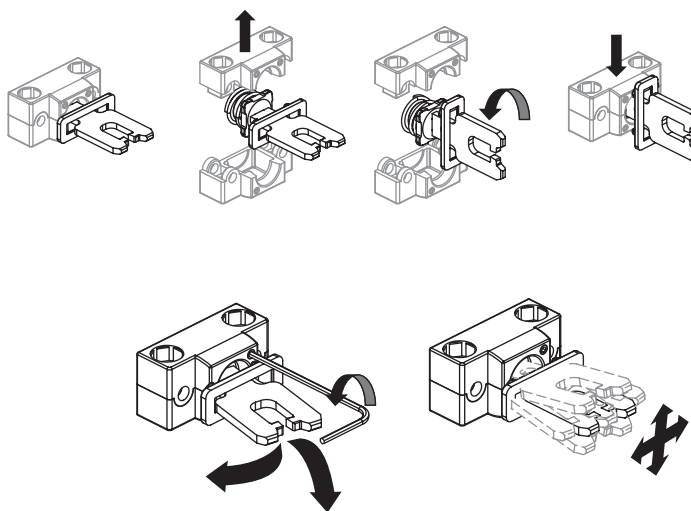

Joined and two directions adjustable actuator for doors with reduced dimensions. The actuator has two couples of fixing holes and it is possible to rotate the actuator-working plan (see picture).

For inaccurate doors

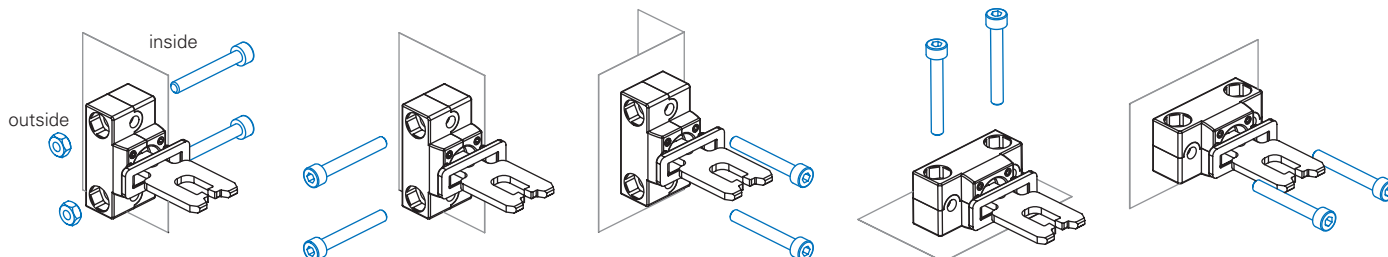

Accessories See page 5/1



- 1
- 1A
- 1B
- 2
- 2A
- 2B
- 2C
- 2D
- 2E
- 3
- 3A
- 3B
- 3C
- 4
- 4A
- 4B
- 4C
- 4D
- 4E
- 4F
- 4G
- 4H
- 5
- 6

Accessories for sealing



Pliers, steel wire and lead seals used to seal the auxiliary release device.

Article	Description
VF FSPB-200	Set of 200 lead seals
VF FSPB-10	Set of 10 lead seals

Article	Description
VF FSFI-400	400 m steel wire roll
VF FSFI-10	10 m steel wire roll

Article	Description
VF FSPZ	Plier without logo



Accessories

Article	Description
VF KB2	Actuator entry locking device



Padlockable device to lock the actuator entry in order to prevent from the accidental closing of the door behind operators while they are inside the machine. To be used only with FG series.



Article	Description
VF KLA371	Set of 2 locking keys



Extra copy of the locking keys to be purchased if further keys are needed (standard supply 2 units). All switches keys have the same code. Other codes on request.

Items with code on the **green** background are available in stock

Other release button lengths

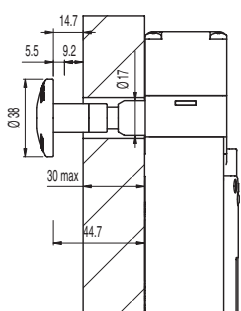

-LP30

Wall thickness length from 15 to 30 mm

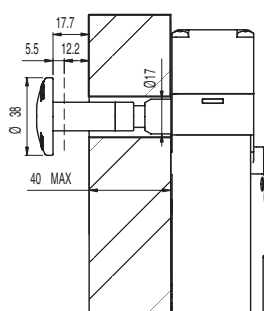

-LP40

Wall thickness length from 30 to 40 mm

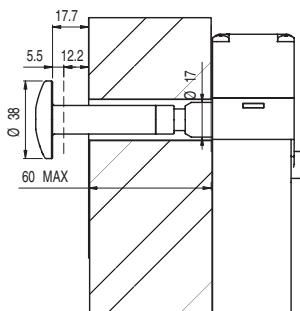

-LP60

Wall thickness length from 40 to 60 mm

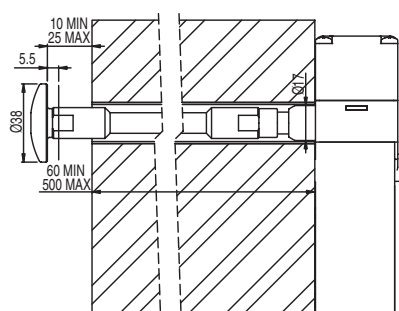

-LPRG

Wall thickness length 60 ... 500 mm

- Avoid torsion and bending on the release button bar.
- Use a bushing or a tube with 18±0,5 mm diameter as a guide inside the wall.
- The M10 threaded bar has to be inserted into the guide in order to avoid its bending. The M10 threaded bar is not supplied with the device.
- To guarantee the device correct operation, keep a distance of 10 to 25 mm between the wall and the release button.
- Keep clean the release push button slipping area. The guide bushing or tube must be cleaned inside, since dirt or chemical products could compromise the device operation.

Safety modules

Pizzato Elettrica s.r.l. offers its customers a wide range of safety modules made considering the typical problems about the control of the safety switches and their real use conditions. There are available safety modules with instantaneous or delayed contacts suitable for type 0 (immediate stop) or type 1 (monitored stop) emergency circuits. Safety switches with solenoid series FG could be connected to safety modules in order to obtain safety circuits up to PLe in accordance with EN ISO 13849. For any technical information or wiring diagram please contact our technical staff.

