

Combination diagrams

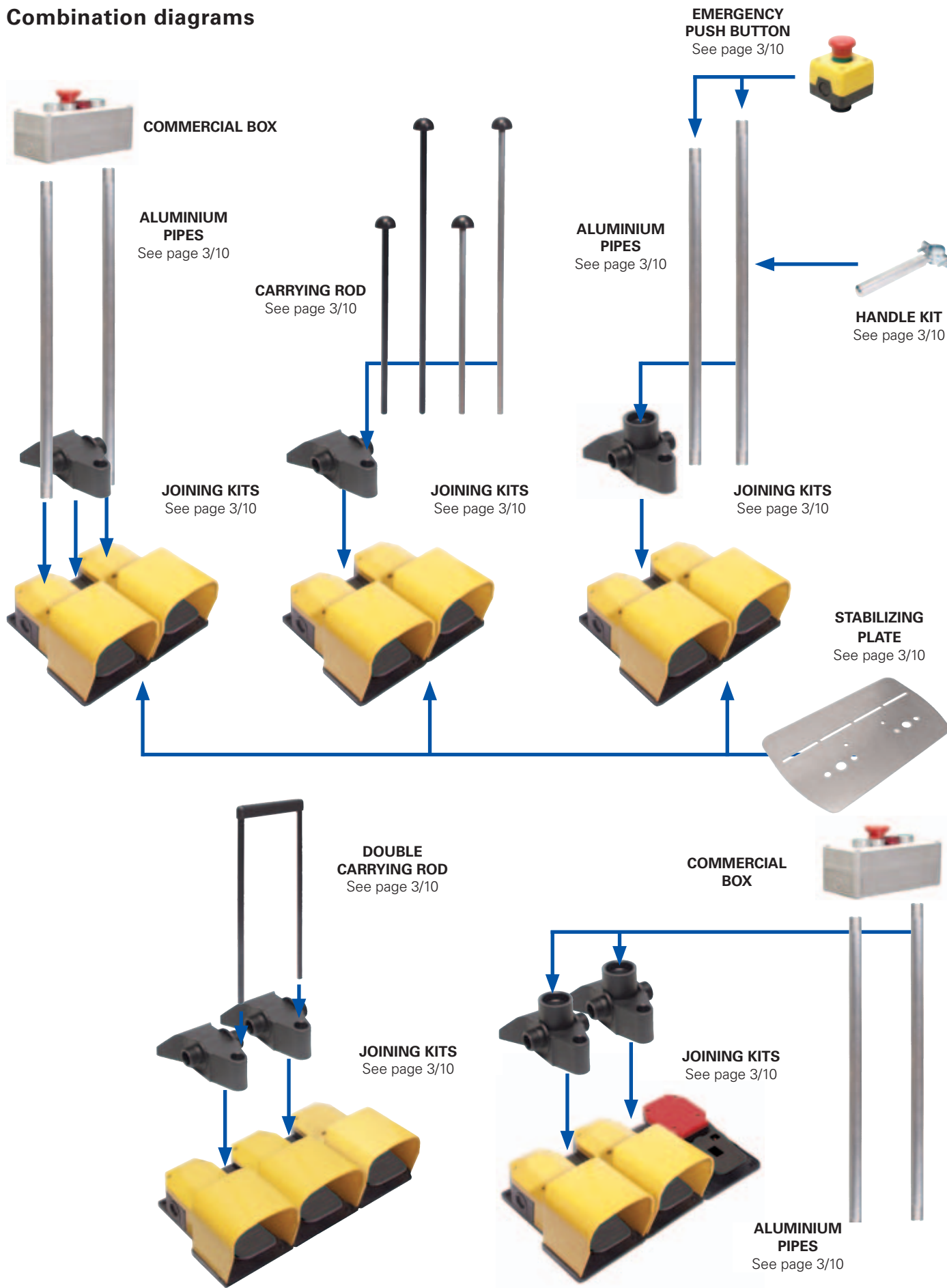

● product option
→ accessory sold separately



1
1A
1B
2
2A
2B
2C
2D
2E
3
3A
3B
3C
4
4A
4B
4C
4D
4E
4F
4G
4H
5
6

Already existing combinations of double foot switches

If you wish to purchase foot switches already assembled, please contact our sales office. Before contacting our offices, please look at the following table where some already assigned multiple foot switches combination are listed.

Code	Left foot switch	Joining device	Right foot switch	Additional kits
PC 2-1	PX 10110	VF KIT20	PX 10110	VF KIT21
PC 2-2	PX 10111	VF KIT20	PX 10111	
PC 2-3	PX 20110	VF KIT20	PX 10210	VF KIT21
PC 2-4	PX 20110	VF KIT20	PX 10110	VF KIT21
PC 2-5	PX 10110	VF KIT20	PX 20110	VF KIT21
PC 2-6	PX 10120	VF KIT20	PX 10110	VF KIT21
PC 2-7	PX 10310	VF KIT20	PX 10310	VF KIT21
PC 2-8	PX 10410	VF KIT20	PX 10410	VF KIT21
PC 2-9	PX 10210	VF KIT20	PX 10210	VF KIT21
PC 2-10	PX 10301	VF KIT20	PX 10301	
PC 2-11	PX 10100	VF KIT20	PX 10100	
PC 2-12	PX 10111	VF KIT20	PX 10111	VF KIT21
PC 2-13	PX 10120	VF KIT20	PX 10120	VF KIT21
PC 2-14	PX 10411	VF KIT20	PX 10411	VF KIT21
PC 2-15	PX 10211	VF KIT20	PX 10201	
PC 2-16	PX 10211	VF KIT20	PX 10211	VF KIT21
PC 2-17	PX 10100	VF KIT20	PX 10210	VF KIT21
PC 2-18	PA 20100	VF KIT20	PX 10110	VF KIT21
PC 2-19	PA 20101	VF KIT20	PX 10111	VF KIT21
PC 2-20	PA 20300	VF KIT20	PX 10310	VF KIT21
PC 2-21	PA 20120	VF KIT20	PX 10110	VF KIT21
PC 2-22	PA 20121	VF KIT20	PX 10111	VF KIT21
PC 2-23	PA 20200	VF KIT20	PX 10810	VF KIT21
PC 2-24	PA 20100	VF KIT20	PX 10210	VF KIT21
PC 2-25	PA 20100	VF KIT20	PX 10100	VF KIT21
PC 2-26	PA 20100	VF KIT20	PA 20100	VF KIT21
PC 2-27	PA 20400	VF KIT20	PA 20400	VF KIT21
PC 2-28	PX 10110	VF KIT30	PX 10110	
PC 2-29	PA 20100	VF KIT30	PX 10110	
PC 2-30	PX 10111	VF KIT30	PX 10111	
PC 2-31	PX 10110-B	VF KIT20	PX 10110-B	
PC 2-32	PX 10111	VF KIT30	PX 10111	VF KIT29-32-50
PC 2-33	PX 20210	VF KIT20	PX 20210	
PC 2-34	PX 20410	VF KIT20	PX 20410	
PC 2-35	PX 20211-M2	VF KIT20	PX 20211-M2	
PC 2-36	PX 30411	VF KIT20	PX 30401	VF KIT21
PC 2-37	PX 10421	VF KIT20	PX 10401	
PC 2-38	PX 10210	VF KIT20	PX 20210	VF KIT21
PC 2-39	PX 40220	VF KIT20	PX 40200	
PC 2-40	PA 20100-M2	VF KIT20	PX 10110-M2	VF KIT22
PC 2-41	PX 10110	VF KIT20	PA 20100	
PC 2-42	PX 10111	VF KIT30	PX 10111	VF KIT31-32
PC 2-43	PX 10100	VF KIT30	PX 10210	VF KIT31-33
PC 2-44	PX 10810	VF KIT30	PX 10110	VF KIT31-32
PC 2-45	PX 40100	VF KIT30	PX 40100	VF KIT31-33
PC 2-46	PA 20100	VF KIT30	PX 10110	VF KIT31-36
PC 2-47	PX 10110	VF KIT30	PX 12040	VF KIT31-34
PC 2-48	PX 10110	VF KIT20+VF KIT61	PX 10110	VF KIT21
PC 2-49	PX 10111	VF KIT30+VF KIT61	PX 10111	VF KIT29-32-50
PC 2-50	PX 40310	VF KIT30	PA 20310	VF KIT 29-32

Note:

VF KIT21, 22, 26, 29, 31, 32, 33, 34, 35, 40, 50 kits are not supplied assembled because, in order to be wired, kits should be in any case disassembled.

How to join several foot switches

Pat. pending

All single foot switches are equipped with knock-out openings on their sides, where the threaded end of the joining kit will be inserted. By clamping the threaded nuts of the joining kits you create a sealed cable conduit from one foot switch to the next. Then, with the supplied screws, the joining kits allow the mechanical clamping and the stabilization of the two (or more) single foot switches in a single object.

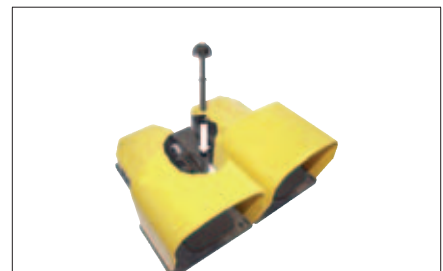
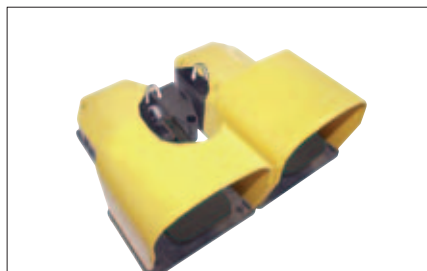
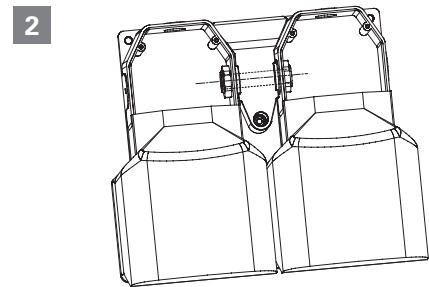
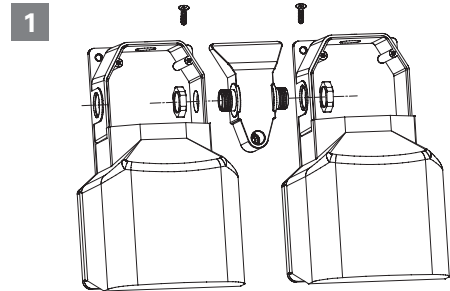

Besides the possibility of joining two to four single foot switches, the joining kits offer the possibility to install a carrying rod or an aluminium pipe. The aluminium pipe allows the electrical connection between the contact blocks of foot switches and an emergency push button connected through the same pipe, keeping a protection degree IP65.



Joining devices for modular multiple foot switches

Article	Description
VF KIT20	Joining devices

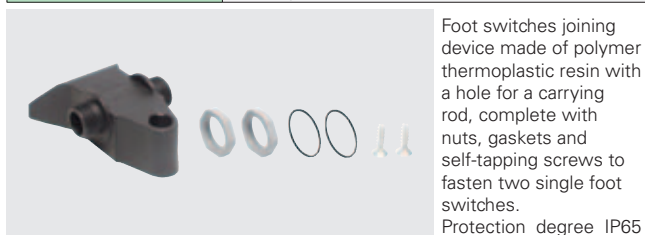

Article	Description
VF KIT30	Joining devices

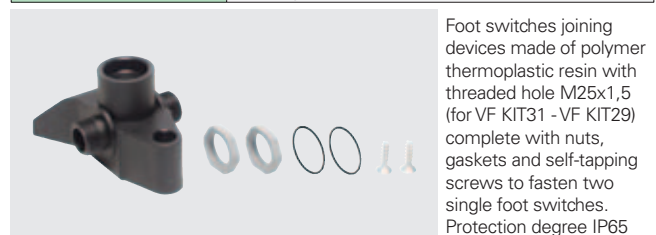



Auxiliary devices for modular multiple foot switches

Article	Description
VF KIT21	Carrying rod kit, L=400 mm
VF KIT22	Carrying rod kit, L=660 mm



Article	Description
VF KIT40	Double carrying rod kit, L=400 mm
VF KIT41	Double carrying rod kit, L=660 mm

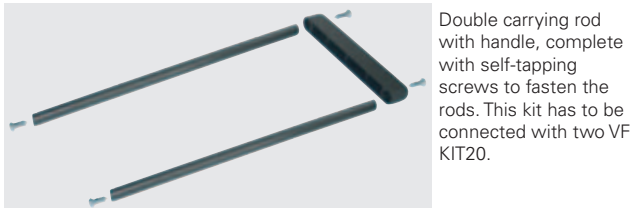

Article	Description
VF KIT18	Brass nuts

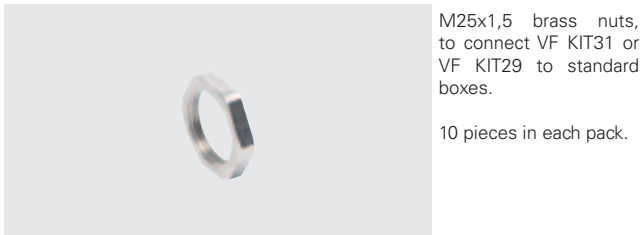

Article	Description
VF KIT50	Handle kit



Article	Description
VF KIT61	Metallic stabilizing plate



Note: VF KIT21, 22, 26, 29, 31, 32, 33, 34, 35, 40, 50 kits are not supplied assembled.

Items with code on the **green** background are available in stock

Article	Description
VF KIT25	Carrying rod kit made of aluminium, L=400 mm
VF KIT26	Carrying rod kit made of aluminium, L=660 mm



Article	Description
VF KIT31	Aluminium pipe Ø 25 mm, L=660 mm
VF KIT29	Aluminium pipe Ø 25 mm, L=740 mm



Article	Description
VF KIT32	Emergency push button kit, 1NC
VF KIT33	Emergency push button kit, 1NC+1NO
VF KIT34	Emergency push button kit, 2NC
VF KIT35	Boxe for push buttons kit Ø 22 mm



Article	Description
VF KIT60	Metallic stabilizing plate



Article	Description
VF KIT71	Yellow metal protection for single footswitch

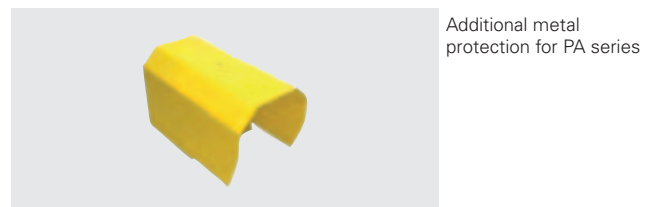

Article	Description
VF KIT81	Yellow metal protection for double footswitches



1
1A
1B
2
2A
2B
2C
2D
2E
3
3A
3B
3C
4
4A
4B
4C
4D
4E
4F
4G
4H
5
6

Combination examples

Double foot switches with joining device, aluminium pipe, stabilizing plate and emergency push button 1 NC

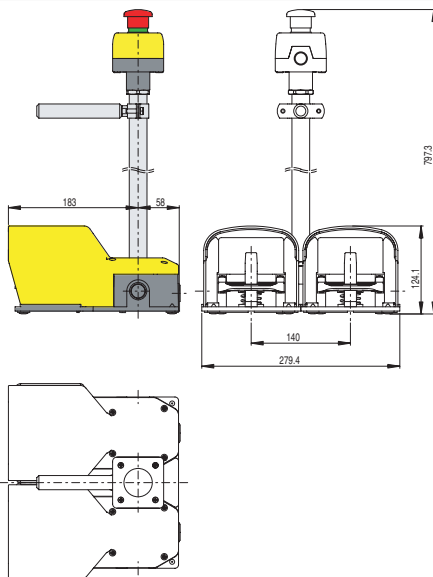

How to order

2x PX 10110	VF KIT30
VF KIT50	VF KIT31
VF KIT32	

Triple foot switches with two joining devices and double carrying rod

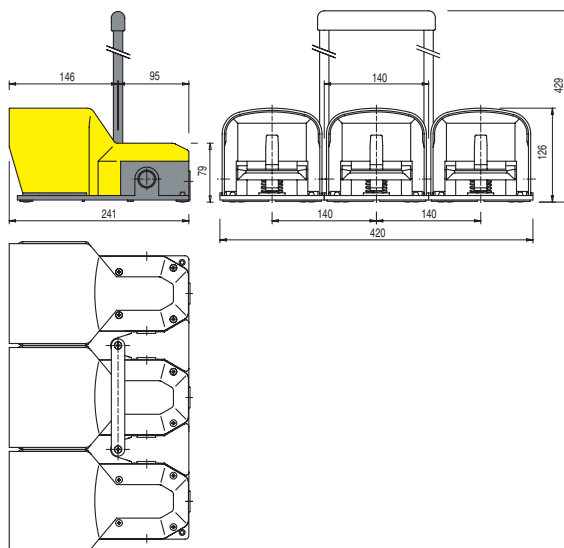

How to order

3x PX 10110	2x VF KIT20
VF KIT40	

Double foot switches with joining device, two aluminium pipes and commercial box

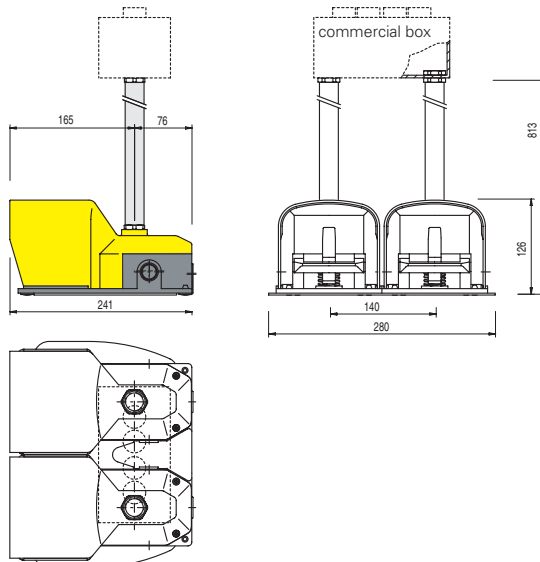

How to order

2x PX 10110-B	VF KIT20
2x VF KIT31	2x VF KIT18
VF KIT61	

Triple foot switches with two joining devices, two aluminium pipes and commercial box

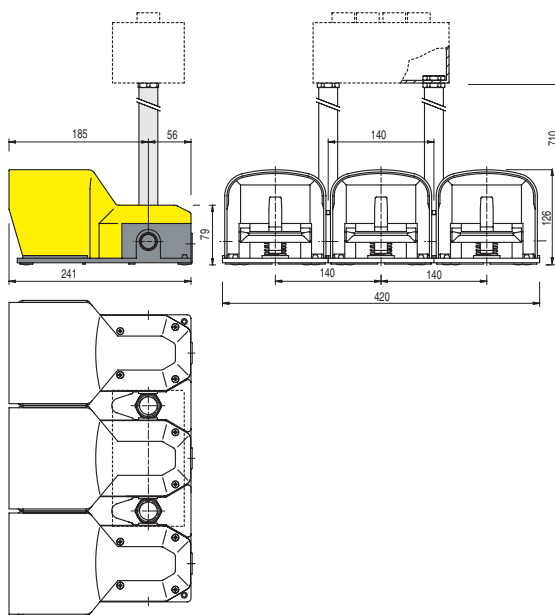

How to order

3x PX 10110	2x VF KIT30
2x VF KIT31	2x VF KIT18

Double foot switches with joining device and carrying rod

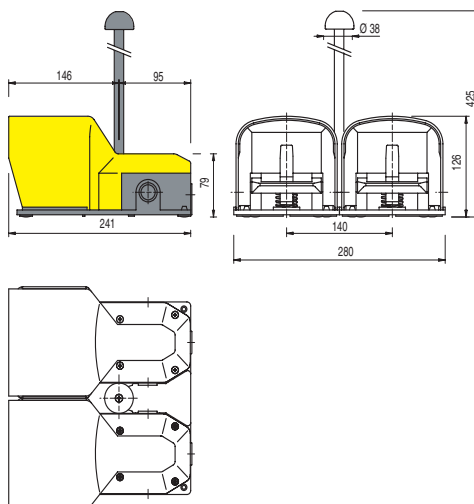

How to order

2x PX 10110	VF KIT20
VF KIT21	

Double foot switches (with and without pedal actuator protection) with joining device and carrying rod

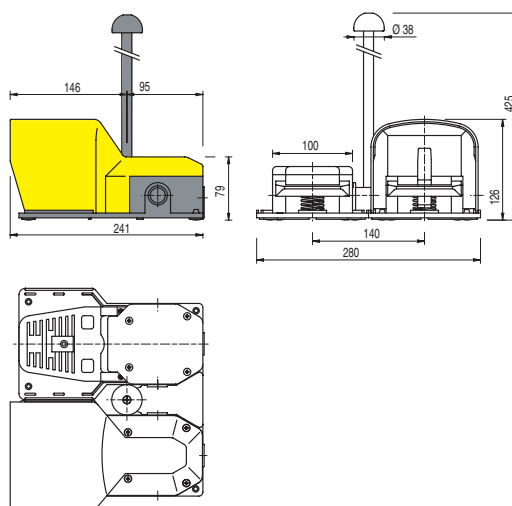

How to order

PX 10110	PA 20100
VF KIT20	VF KIT21