

IDECODE - Coded Interlock Switches - Type: MPC

Coded Magnetic Actuation

Switching Tolerance up to 10mm



Compact yet robust fitting suitable for all small guard applications.
LED indication.

Hygienic screw covers ensure suitability for Food Processing washdown.
Cost effective interlock solution.

Wide sensing at 10mm.

High Specification polyester housing with backplate

Can be mounted unobtrusively in channels or behind doors, left or right cable exit

Up to: PLe ISO 13849-1 SIL 3 EN 62061 Cat 4 EN 954-1

2NC 1NO circuits - High switching life - no moving parts

Specified to 80C but designed to work up to 100C
Will operate with most EN 954-1 Cat.4 Safety Relays

Quick Connect (QC) M12 8 way Male Plug (Pin view from switch)	Flying Lead Colours	Circuit (Actuator Present)	Output Types Solid State
8	Orange	Auxiliary NO or NC	200mA Max. 24Vdc
5	Brown	Auxiliary NO or NC	
4	Yellow	Safety NC2 +ve	200mA Max. 24Vdc
6	Green	Safety NC2 -ve	
7	Black	Safety NC1 +ve	200mA Max. 24Vdc
1	White	Safety NC1 -ve	
2	Red	Supply +24Vdc	Supply 24Vdc +/- 10%
3	Blue	Supply 0Vdc	

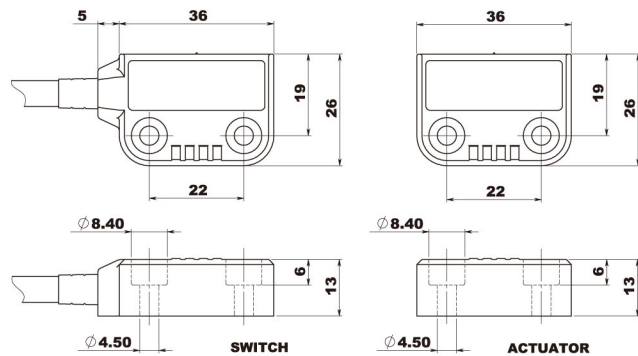
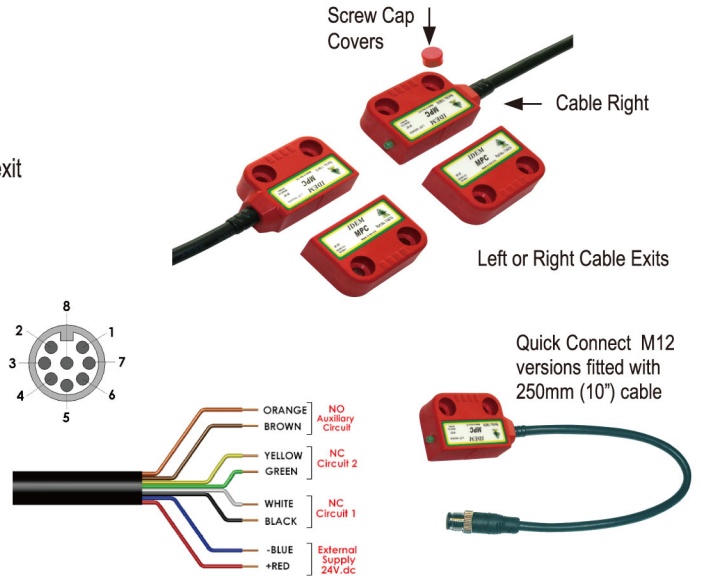

Connection example - coded switches

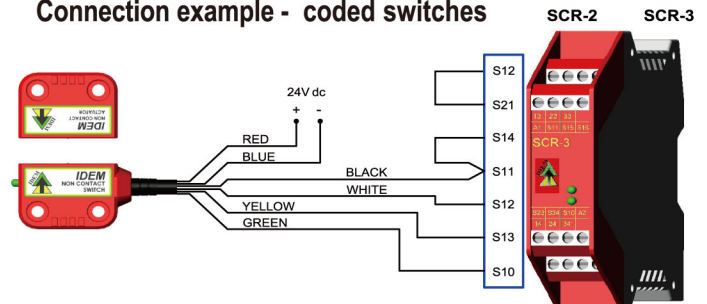

Single switch connected to an SCR-2 or SCR-3 to give Dual Channel monitoring with Automatic Start.

Standards EN1088 IEC 60947-5-3 EN 60204-1
ISO 13849-1 EN62061 EN 954-1 UL508

Safety Classification and Reliability Data:

Switching Reliability EN 954-1	3.3 x 10 ⁶ operations at 100mA load up to Category 4 with Safety Relay
ISO 13849-1 EN 62061	up to PLe depending upon system architecture up to SIL3 depending upon system architecture
Safety Data - Annual Usage PFHd	8 cycles per hour / 24 hours per day / 365 days 2.52 x 10 ⁻⁸
Proof Test Interval (Life) MTTfd	47 years 470 years
Safety Channel 1 NC	24V.dc 0.2 A Max. Rating
Safety Channel 2 NC	24V.dc 0.2 A Max. Rating
Safety Channel 3 NO	24V.dc 0.2 A Max. Rating
Minimum switched current	10V. dc 1mA
Dielectric withstand	250V.ac
Insulation Resistance	100 Mohms
Recommended setting gap	5mm
Switching Distance: (Target to target)	Sao 8mm Close Sar 12mm Open
Tolerance to misalignment	5mm in any direction from 5mm setting gap
Switching frequency	1.0 Hz maximum
Approach speed	200mm/m. to 1000mm/s.
Body Material	UL approved polyester
Temperature Range	-25 +80C.
Enclosure Protection	IP69K IP67
Shock Resistance	IEC 68-2-27 11ms 30g
Vibration Resistance	IEC 68-2-6 10-55 Hz. 1mm
Cable Type	PVC 6 or 8 core 6mm O.D.
Mounting Bolts	2 x M4 Tightening torque 1.0 Nm
Mounting Position	Any

140101	Female QC Lead	M12 Female 5m. 8 way
140102	Female QC Lead	M12 Female 10m. 8 way

For all IDEM switches the NC circuits are closed when the guard is closed and the actuator present

Sales Number	Type	Cable Length	Circuits
114101	MPC Cable Right	2M	2NC
114102	MPC Cable Right	5M	2NC
114103	MPC Cable Right	10M	2NC
114104	MPC Cable Right	QC-M12*	2NC
114105	MPC Cable Right	2M	2NC 1NO
114106	MPC Cable Right	5M	2NC 1NO
114107	MPC Cable Right	10M	2NC 1NO
114108	MPC Cable Right	QC-M12*	2NC 1NO
114117	MPC Cable Right	2M	3NC
114118	MPC Cable Right	5M	3NC
114119	MPC Cable Right	10M	3NC
114120	MPC Cable Right	QC-M12*	3NC
114109	MPC Cable Left	2M	2NC
114110	MPC Cable Left	5M	2NC
114111	MPC Cable Left	10M	2NC
114112	MPC Cable Left	QC-M12*	2NC
114113	MPC Cable Left	2M	2NC 1NO
114114	MPC Cable Left	5M	2NC 1NO
114115	MPC Cable Left	10M	2NC 1NO
114116	MPC Cable Left	QC-M12*	2NC 1NO
114121	MPC Cable Left	2M	3NC
114122	MPC Cable Left	5M	3NC
114123	MPC Cable Left	10M	3NC
114124	MPC Cable Left	QC-M12*	3NC

* Other QC sizes available upon request

Note: 2NC 1NO versions have 2NC Safety and 1NO Auxiliary Circuits
3NC versions have 2NC Safety and 1NC Auxiliary Circuits

Available without LED if required

EUROCODE - Coded Non Contact - Type: LPC

Coded Magnetic Actuation

Switching Tolerance up to 14mm



Popular European fitting suitable for all industry applications.

Can be high pressure hosed at high temperature - IP69K

Wide 14mm sensing - high tolerance to misalignment

LED indication

Up to: PLe ISO 13849-1 SIL 3 EN 62061 Cat 4 EN 954-1

2NC 1NO circuits - High switching life - no moving parts

Quick connect versions.

Magnet Holding versions for use with small guards

Specified to 80C but designed to work up to 100C
Will operate with most EN 954-1 Cat.4 Safety Relays



Quick Connect M12 versions fitted with 250mm (10") cable

Connection example - coded switches

Three switches connected in series to an SCR-2 or SCR-3 to give Dual Channel monitoring with auto start and contactor feedback check.

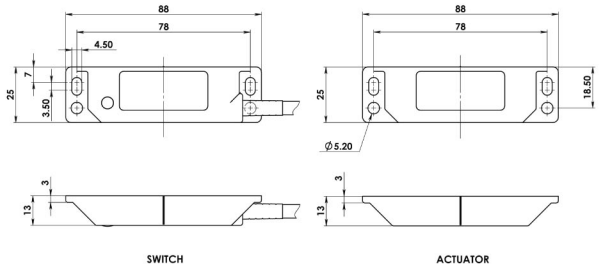
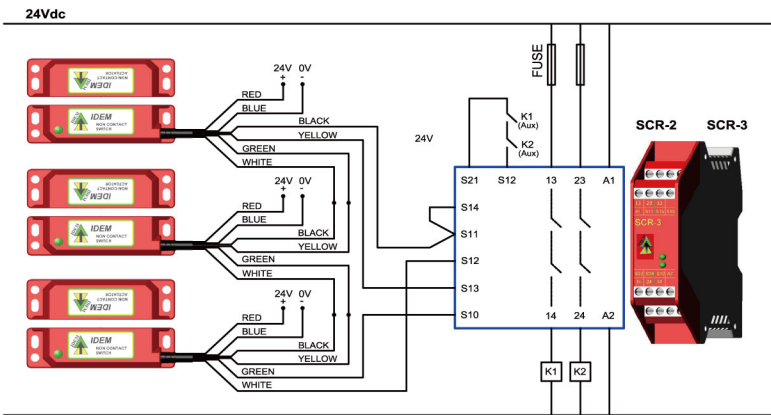

Standards EN1088 IEC 60947-5-3 EN 60204-1
 ISO 13849-1 EN62061 EN 954-1 UL508

Safety Classification and Reliability Data:

Switching Reliability	3.3 x 10 ⁶ operations at 100mA load up to Category 4 with Safety Relay
EN 954-1	up to PLe depending upon system architecture
ISO 13849-1	up to SIL3 depending upon system architecture
EN 62061	8 cycles per hour / 24 hours per day / 365 days
Safety Data - Annual Usage	2.52 x 10 ⁻⁸
PFHd	47 years
Proof Test Interval (Life)	470 years
MTTFd	470 years
Safety Channel 1 NC	24V.dc 0.2 A Max. Rating
Safety Channel 2 NC	24V.dc 0.2 A Max. Rating
Safety Channel 3 NO	24V.dc 0.2 A Max. Rating
Minimum switched current	10V. dc 1mA
Dielectric withstand	250V.ac
Insulation Resistance	100 Mohms
Recommended setting gap	5mm
Switching Distance:	Sao 10mm Close
(Target to target)	Sar 20mm Open
Tolerance to misalignment	5mm in any direction from 5mm setting gap
Switching frequency	1.0 Hz maximum
Approach speed	200mm/m. to 1000mm/s.
Body Material	UL approved polyester
Temperature Range	-25 +80C.
Enclosure Protection	IP69K IP67
Shock Resistance	IEC 68-2-27 11ms 30g
Vibration Resistance	IEC 68-2-6 10-55 Hz. 1mm
Cable Type	PVC 6 or 8 core 6mm O.D.
Mounting Bolts	2 x M4 Tightening torque 1.0 Nm
Mounting Position	Any

Magnetic Holding versions



At 1mm setting gap: 10N.
 At 5mm setting gap: 5N.

Sales Number	Type	Cable Length	Circuits
110001	Eurocode LPC	2M	2NC
110002	Eurocode LPC	5M	2NC
110003	Eurocode LPC	10M	2NC
110004	Eurocode LPC	QC-M12	2NC
110005	Eurocode LPC	2M	2NC 1NO
110006	Eurocode LPC	5M	2NC 1NO
110007	Eurocode LPC	10M	2NC 1NO
110008	Eurocode LPC	QC-M12	2NC 1NO
110070	Eurocode LPC	2M	3NC
110071	Eurocode LPC	5M	3NC
110072	Eurocode LPC	10M	3NC
110073	Eurocode LPC	QC-M12	3NC

For Magnetic Holding Versions add 10N to Part Number
 Example:
 LPC 2NC 1NO 5m. with Magnetic Hold Part 110006-10N

Note: 2NC 1NO versions have 2NC Safety and 1NO Auxiliary Circuits
 3NC versions have 2NC Safety and 1NC Auxiliary Circuits

Available without LED if required

Quick Connect (QC) M12 8 way Male Plug (Pin view from switch)	Flying Lead Colours	Circuit (Actuator Present)	Output Types Solid State
8	Orange	Auxiliary NO or NC	200mA Max. 24Vdc
5	Brown	Auxiliary NO or NC	
4	Yellow	Safety NC2 +ve	200mA Max. 24Vdc
6	Green	Safety NC2 -ve	
7	Black	Safety NC1 +ve	200mA Max. 24Vdc
1	White	Safety NC1 -ve	
2	Red	Supply +24Vdc	Supply 24Vdc +/- 10%
3	Blue	Supply 0Vdc	

140101	Female QC Lead	M12 Female 5m.	8 way
140102	Female QC Lead	M12 Female 10m.	8 way

For all IDEM switches the NC circuits are closed when the guard is closed and the actuator present

IDECODE - Coded Non Contact - Type: SPC

Coded Magnetic Actuation

Switching Tolerance up to 14mm



Will operate with most Safety Relays

Specified to 80C but designed to work up to 100C

Universal fitting - established 22mm fixing footprint suitable for most general applications.

Withstands environments where high humidity or hose down is required.

Durable polyester housing.

Wide 14mm sensing and high tolerance to misalignment.

Up to: PLe ISO 13849-1 SIL 3 EN 62061 Cat 4 EN 954-1

2NC 1NO circuits - High switching life - no moving parts

Quick connect versions.

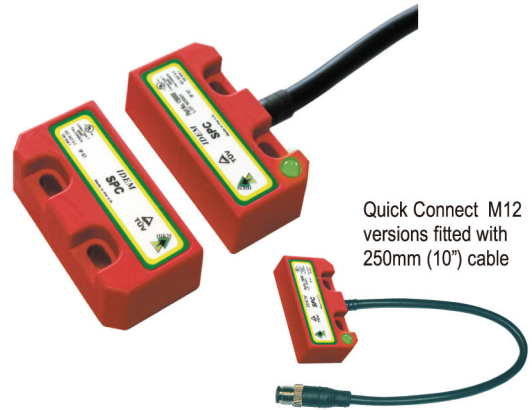

Quick Connect M12 versions fitted with 250mm (10") cable

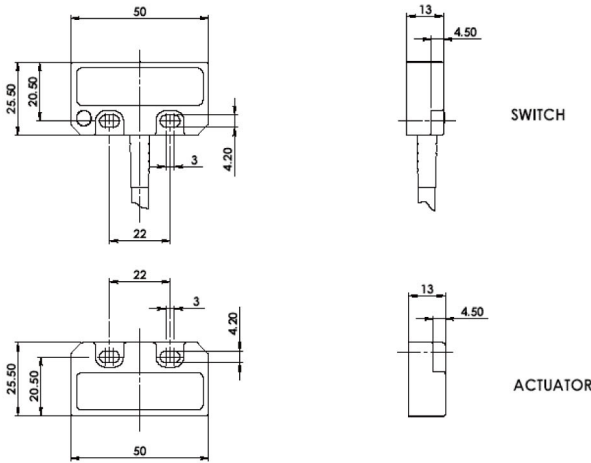

Quick Connect (QC) M12 8 way Male Plug (Pin view from switch)	Flying Lead Colours	Circuit (Actuator Present)	Output Types Solid State
8	Orange	Auxiliary NO or NC	200mA Max. 24Vdc
5	Brown	Auxiliary NO or NC	
4	Yellow	Safety NC2 +ve	200mA Max. 24Vdc
6	Green	Safety NC2 -ve	
7	Black	Safety NC1 +ve	200mA Max. 24Vdc
1	White	Safety NC1 -ve	
2	Red	Supply +24Vdc	Supply 24Vdc +/- 10%
3	Blue	Supply 0Vdc	



Standards EN1088 IEC 60947-5-3 EN 60204-1 ISO 13849-1 EN62061 EN 954-1 UL508

Safety Classification and Reliability Data:

Switching Reliability	3.3 x 10 ⁶ operations at 100mA load up to Category 4 with Safety Relay
EN 954-1	up to PLe depending upon system architecture
ISO 13849-1	up to SIL3 depending upon system architecture
EN 62061	8 cycles per hour / 24 hours per day / 365 days
Safety Data - Annual Usage	2.52 x 10 ⁻⁸
PFFhd	47 years
Proof Test Interval (Life)	470 years
MTTFd	470 years
Safety Channel 1 NC	24V.dc 0.2 A Max. Rating
Safety Channel 2 NC	24V.dc 0.2 A Max. Rating
Safety Channel 3 NO	24V.dc 0.2 A Max. Rating
Minimum switched current	10V. dc 1mA
Dielectric withstand	250V.ac
Insulation Resistance	100 Mohms
Recommended setting gap	5mm
Switching Distance:	Sao 10mm Close
(Target to target)	Sar 20mm Open
Tolerance to misalignment	5mm in any direction from 5mm setting gap
Switching frequency	1.0 Hz maximum
Approach speed	200mm/m. to 1000mm/s.
Body Material	UL approved polyester
Temperature Range	-25 +80C.
Enclosure Protection	IP69K IP67
Shock Resistance	IEC 68-2-27 11ms 30g
Vibration Resistance	IEC 68-2-6 10-55 Hz. 1mm
Cable Type	PVC 6 or 8 core 6mm O.D.
Mounting Bolts	2 x M4 Tightening torque 1.0 Nm
Mounting Position	Any

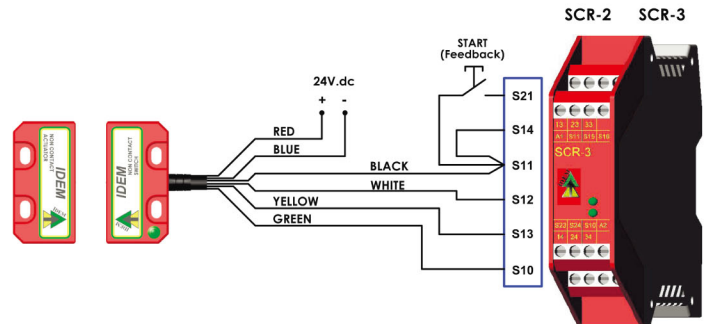

140101	Female QC Lead	M12 Female 5m.	8 way
140102	Female QC Lead	M12 Female 10m.	8 way

Sales Number	Type	Cable Length	Circuits
111001	Idecode SPC	2M	2NC
111002	Idecode SPC	5M	2NC
111003	Idecode SPC	10M	2NC
111004	Idecode SPC	QC-M12	2NC
111005	Idecode SPC	2M	2NC 1NO
111006	Idecode SPC	5M	2NC 1NO
111007	Idecode SPC	10M	2NC 1NO
111008	Idecode SPC	QC-M12	2NC 1NO
111105	Idecode SPC	2M	3NC
111106	Idecode SPC	5M	3NC
111107	Idecode SPC	10M	3NC
111108	Idecode SPC	QC-M12	3NC

Note: 2NC 1NO versions have 2NC Safety and 1NO Auxiliary Circuits
3NC versions have 2NC Safety and 1NC Auxiliary Circuits

Available without LED if required

For all IDEM switches the NC circuits are closed when the guard is closed and the actuator present

IDECODE - Coded Non Contact - Type: CPC

Coded Magnetic Actuation

Switching Tolerance up to 14mm



- Slim fitting suitable for all industry applications.
- Easy to install within narrow frame structures.
- Durable polyester housing.
- Wide 14mm sensing and high tolerance to misalignment.
- LED indication
- Up to: PLe ISO 13849-1 SIL 3 EN 62061 Cat 4 EN 954-1
- 2NC 1NO circuits - High switching life - no moving parts
- Quick connect versions.

Specified to 80C but designed to work up to 100C.
Will operate with most Safety Relays



Connection example - coded switches

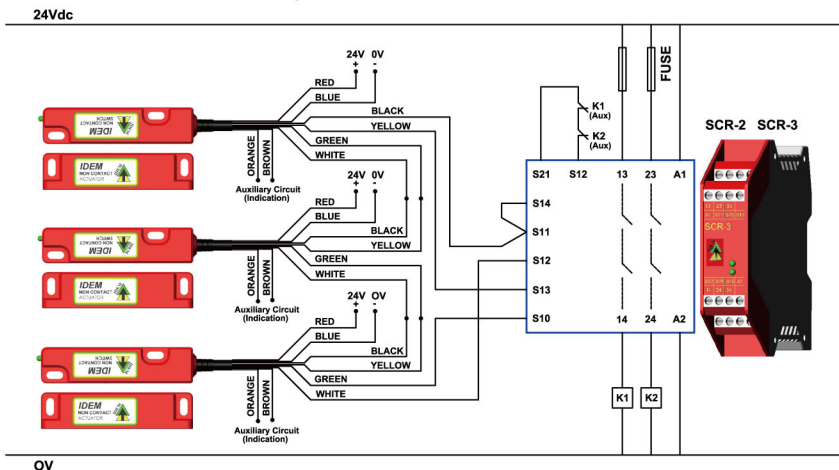

Three switches connected in series to an SCR - 2 or SCR - 3 to give Dual Channel monitoring with auto start and contactor feedback check. Optional auxiliary circuits provide for remote signalling from each switch.

Quick Connect (QC) M12 8 way Male Plug (Pin view from switch)	Flying Lead Colours	Circuit (Actuator Present)	Output Types Solid State
8	Orange	Auxiliary NO or NC	200mA Max. 24Vdc
5	Brown	Auxiliary NO or NC	
4	Yellow	Safety NC2 +ve	200mA Max. 24Vdc
6	Green	Safety NC2 -ve	
7	Black	Safety NC1 +ve	200mA Max. 24Vdc
1	White	Safety NC1 -ve	
2	Red	Supply +24Vdc	Supply 24Vdc +/- 10%
3	Blue	Supply 0Vdc	

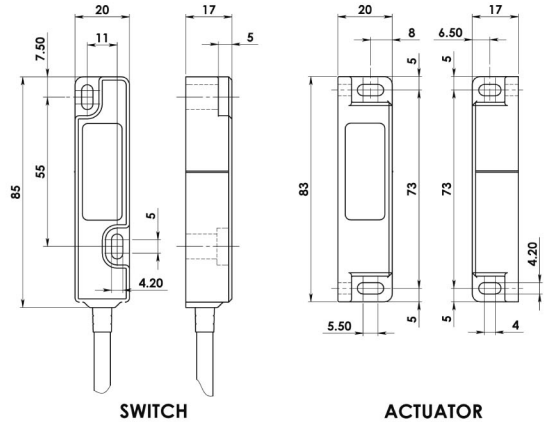
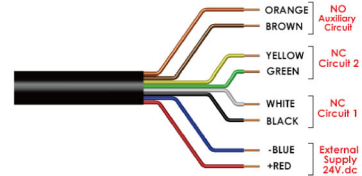
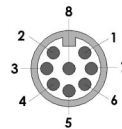

Sales Number	Type	Cable Length	Circuits
115001	Idecode CPC	2M	2NC
115002	Idecode CPC	5M	2NC
115003	Idecode CPC	10M	2NC
115004	Idecode CPC	QC-M12	2NC
115005	Idecode CPC	2M	2NC 1NO
115006	Idecode CPC	5M	2NC 1NO
115007	Idecode CPC	10M	2NC 1NO
115008	Idecode CPC	QC-M12	2NC 1NO

Available without LED if required

140101	Female QC Lead	M12 Female 5m.	8 way
140102	Female QC Lead	M12 Female 10m.	8 way

For all IDEM switches the NC circuits are closed when the guard is closed and the actuator present

Standards EN1088 IEC 60947-5-3 EN 60204-1 ISO 13849-1 EN62061 EN 954-1 UL508

Safety Classification and Reliability Data:

Switching Reliability EN 954-1	3.3 x 10 ⁶ operations at 100mA load up to Category 4 with Safety Relay
ISO 13849-1 EN 62061	up to PLe depending upon system architecture up to SIL3 depending upon system architecture
Safety Data - Annual Usage PFHd	8 cycles per hour / 24 hours per day / 365 days 2.52 x 10 ⁻⁸
Proof Test Interval (Life) MTTFd	47 years 470 years
Safety Channel 1 NC	24V.dc 0.2 A Max. Rating
Safety Channel 2 NC	24V.dc 0.2 A Max. Rating
Safety Channel 3 NO	24V.dc 0.2 A Max. Rating
Minimum switched current	10V. dc 1mA
Dielectric withstand	250V.ac
Insulation Resistance	100 Mohms
Recommended setting gap	5mm
Switching Distance: (Target to target)	Sao 10mm Close Sar 20mm Open
Tolerance to misalignment	5mm in any direction from 5mm setting gap
Switching frequency	1.0 Hz maximum
Approach speed	200mm/m. to 1000mm/s.
Body Material	UL approved polyester
Temperature Range	-25 +80C.
Enclosure Protection	IP69K IP67
Shock Resistance	IEC 68-2-27 11ms 30g
Vibration Resistance	IEC 68-2-6 10-55 Hz. 1mm
Cable Type	PVC 6 or 8 core 6mm O.D.
Mounting Bolts	2 x M4 Tightening torque 1.0 Nm
Mounting Position	Any

IDECODE - Coded Non Contact - Type WPC

Coded Magnetic Actuation

Switching Tolerance up to 14mm



Slim fitting suitable for all industry applications.

Wide 14mm sensing high tolerance to misalignment.

LED indication - no moving parts - survives shock and vibration

Up to: PLe ISO 13849-1 SIL 3 EN 62061 Cat 4 EN 954-1

2NC 1NO circuits - High switching life - no moving parts

Quick connect versions.

**Specified to 80C but designed to work up to 100C.
Will operate with most Safety Relays**



Quick Connect M12 versions fitted with 250mm (10") cable

Quick Connect (QC) M12 8 way Male Plug (Pin view from switch)	Flying Lead Colours	Circuit (Actuator Present)	Output Types Solid State
8	Orange	Auxiliary NO or NC	200mA Max. 24Vdc
5	Brown	Auxiliary NO or NC	
4	Yellow	Safety NC2 +ve	200mA Max. 24Vdc
6	Green	Safety NC2 -ve	
7	Black	Safety NC1 +ve	200mA Max. 24Vdc
1	White	Safety NC1 -ve	
2	Red	Supply +24Vdc	Supply 24Vdc +/- 10%
3	Blue	Supply 0Vdc	

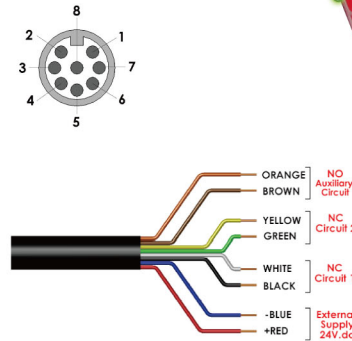

Connection example - coded switches

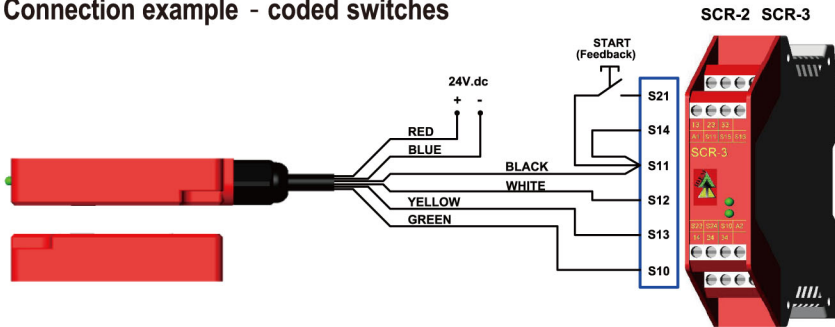

One Switch connected to an SCR-2 or SCR-3 to give Dual Channel monitoring with manual start and contactor feedback check.

Standards	EN1088 IEC 60947-5-3 EN 60204-1 ISO 13849-1 EN62061 EN 954-1 UL508
Safety Classification and Reliability Data:	
Switching Reliability	3.3 x 10 ⁶ operations at 100mA load up to Category 4 with Safety Relay
EN 954-1	up to PLe depending upon system architecture
ISO 13849-1	up to SIL3 depending upon system architecture
EN 62061	
Safety Data - Annual Usage	8 cycles per hour / 24 hours per day / 365 days
PFHd	2.52 x 10 ⁻⁸
Proof Test Interval (Life)	47 years
MTTFd	470 years
Safety Channel 1	NC 24V.dc 0.2 A Max. Rating
Safety Channel 2	NC 24V.dc 0.2 A Max. Rating
Safety Channel 3	NO 24V.dc 0.2 A Max. Rating
Minimum switched current	10V. dc 1mA
Dielectric withstand	250V.ac
Insulation Resistance	100 Mohms
Recommended setting gap	5mm
Switching Distance:	Sao 10mm Close
(Target to target)	Sar 20mm Open
Tolerance to misalignment	5mm in any direction from 5mm setting gap
Switching frequency	1.0 Hz maximum
Approach speed	200mm/m. to 1000mm/s.
Body Material	UL approved polyester
Temperature Range	-25 +80C.
Enclosure Protection	IP69K IP67
Shock Resistance	IEC 68-2-27 11ms 30g
Vibration Resistance	IEC 68-2-6 10-55 Hz. 1mm
Cable Type	PVC 6 or 8 core 6mm O.D.
Mounting Bolts	2 x M4 Tightening torque 1.0 Nm
Mounting Position	Any

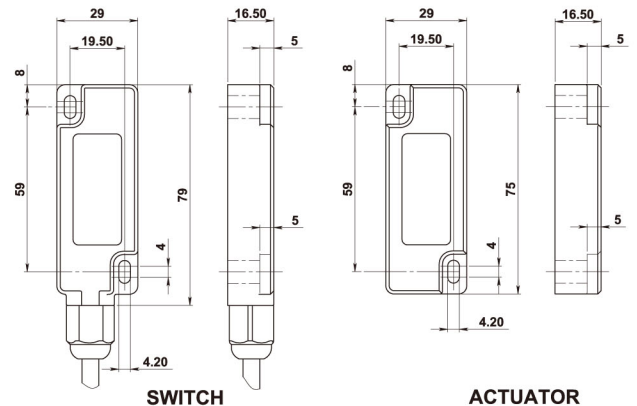

Sales Number	Type	Cable Length	Circuits
112013	Idecode WPC	2M	2NC
112014	Idecode WPC	5M	2NC
112015	Idecode WPC	10M	2NC
112016	Idecode WPC	QC-M12	2NC
112017	Idecode WPC	2M	2NC 1NO
112018	Idecode WPC	5M	2NC 1NO
112019	Idecode WPC	10M	2NC 1NO
112020	Idecode WPC	QC-M12	2NC 1NO

Available without LED if required

For all IDEM switches the NC circuits are closed when the guard is closed and the actuator present

IDECODE Coded Non Contact Type: RPC



Coded Magnetic Actuation

Switching Tolerance up to 10mm

Cylindrical fitting suitable for all industry applications.

Easy to install - M30 threaded body - easy to set

Wide 10mm sensing

Robust, suitable for harsh environments

Can be flush mounted

LED indication

Up to: PLe ISO 13849-1 SIL 3 EN 62061 Cat 4 EN 954-1

2NC 1NO circuits - High switching life - no moving parts

Quick connect versions.

Specified to 80C but designed to work up to 100C.
Will operate with most Safety Relays

Connection example - coded switches

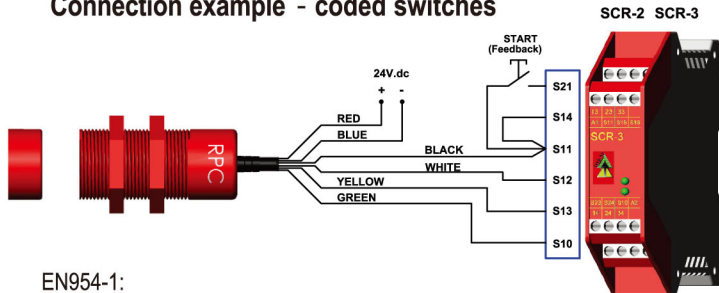

EN954-1:

One switch to one Safety Relay - Cat.4

Multiple switches to one Safety Relay - Cat.3.

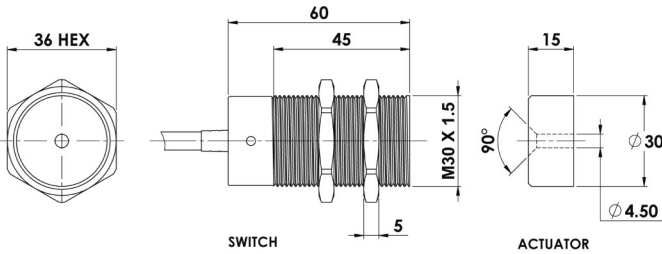

Quick Connect M12 versions fitted with 250mm (10") cable

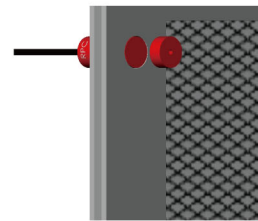

Can be flush mounted

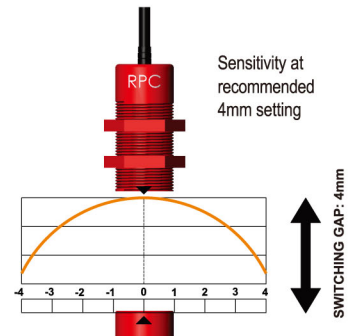

SWITCHING GAP: 4mm

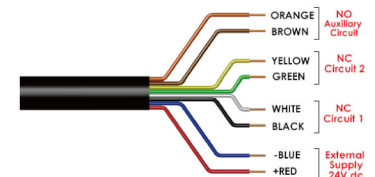
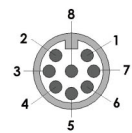

Standards	EN1088 IEC 60947-5-3 EN 60204-1 ISO 13849-1 EN62061 EN 954-1 UL508
Safety Classification and Reliability Data:	
Switching Reliability	3.3 x 10 ⁶ operations at 100mA load up to Category 4 with Safety Relay
EN 954-1	up to PLe depending upon system architecture
ISO 13849-1	up to SIL3 depending upon system architecture
EN 62061	8 cycles per hour / 24 hours per day / 365 days
Safety Data - Annual Usage	8 cycles per hour / 24 hours per day / 365 days
PFHd	2.52 x 10 ⁻⁶
Proof Test Interval (Life)	47 years
MTTFd	470 years
Safety Channel 1 NC	24V.dc 0.2 A Max. Rating
Safety Channel 2 NC	24V.dc 0.2 A Max. Rating
Safety Channel 3 NO	24V.dc 0.2 A Max. Rating
Minimum switched current	10V. dc 1mA
Dielectric withstand	250V.ac
Insulation Resistance	100 Mohms
Recommended setting gap	5mm
Switching Distance:	Sao 8mm Close
(Target to target)	Sar 12mm Open
Tolerance to misalignment	5mm in any direction from 5mm setting gap
Switching frequency	1.0 Hz maximum
Approach speed	200mm/m. to 1000mm/s.
Body Material	UL approved polyester
Temperature Range	-25 +80C.
Enclosure Protection	IP69K IP67
Shock Resistance	IEC 68-2-27 11ms 30g
Vibration Resistance	IEC 68-2-6 10-55 Hz. 1mm
Cable Type	PVC 6 or 8 core 6mm O.D.
Mounting Position	Any

140101	Female QC Lead	M12 Female 5m. 8 way
140102	Female QC Lead	M12 Female 10m. 8 way

Quick Connect (QC) M12 8 way Male Plug (Pin view from switch)	Flying Lead Colours	Circuit (Actuator Present)	Output Types Solid State
8	Orange	Auxiliary NO or NC	200mA Max. 24Vdc
5	Brown	Auxiliary NO or NC	
4	Yellow	Safety NC2 +ve	200mA Max. 24Vdc
6	Green	Safety NC2 -ve	
7	Black	Safety NC1 +ve	200mA Max. 24Vdc
1	White	Safety NC1 -ve	
2	Red	Supply +24Vdc	Supply 24Vdc +/- 10%
3	Blue	Supply 0Vdc	

Sales Number	Type	Cable Length	Circuits
116001	Idecode RPC	2M	2NC
116002	Idecode RPC	5M	2NC
116003	Idecode RPC	10M	2NC
116004	Idecode RPC	QC-M12	2NC
116005	Idecode RPC	2M	2NC 1NO
116006	Idecode RPC	5M	2NC 1NO
116007	Idecode RPC	10M	2NC 1NO
116008	Idecode RPC	QC-M12	2NC 1NO
116105	Idecode RPC	2M	3NC
116106	Idecode RPC	5M	3NC
116107	Idecode RPC	10M	3NC
116108	Idecode RPC	QC-M12	3NC

Note: 2NC 1NO versions have 2NC Safety and 1NO Auxiliary Circuits
 3NC versions have 2NC Safety and 1NC Auxiliary Circuits

Available without LED if required

Coded Non Contact - Type: KOBRACODE - KPC

Coded Magnetic Actuation

Switching Tolerance up to 10mm

Plastic Housing



Will operate with most Safety Relays

Front and End Actuation

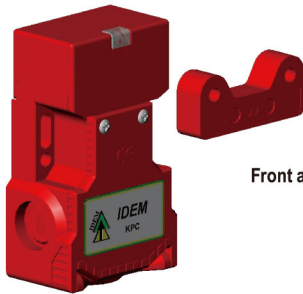

Front actuation

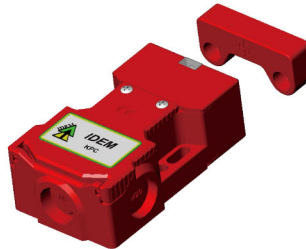

End Actuation

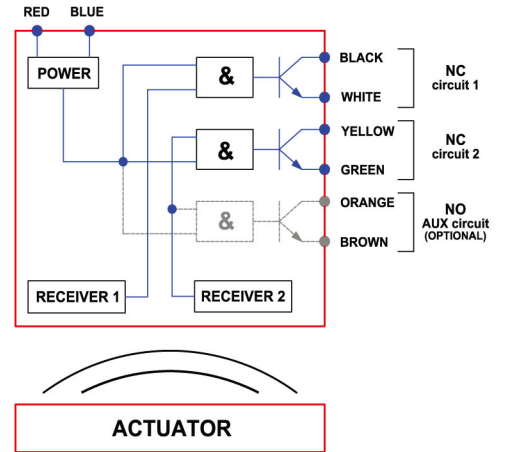

Sensing principle:

Application:

IDEM KPC Coded Non Contact switches are designed to interlock hinge, sliding or removal guard doors. They have an industry standard fixing and are specifically advantageous when :

- a) severe guard alignment exists using traditional tongue type versions
- b) long mechanical life is required (no moving or touching parts)

When used in combination with Dual Channel Safety Relays they can be used to provide up to:
PLe ISO 13849-1 SIL 3 EN 62061 Cat.4 EN 954-1

Features:

- Industry housing shape 52mm wide 98mm long 40mm fixing
- 2NC 1NO semiconductor outputs for connection to safety relay
- Visual LED indication of switch status
- Fully encapsulated sealing and pre-wired 2m., 5m., or 10m. cable
- M12 8 way Quick connect version - flying lead 150mm

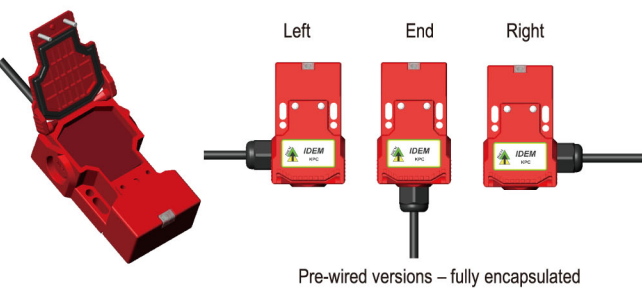

Pre-wired versions – fully encapsulated

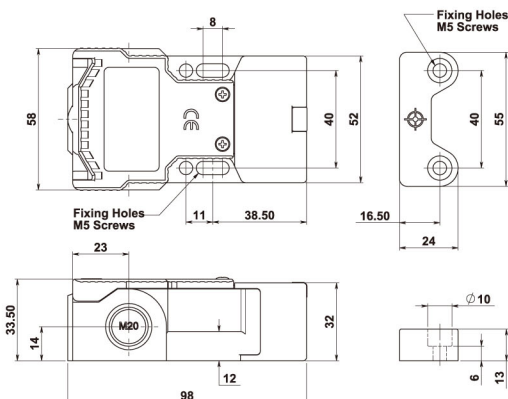

Standards	EN1088 IEC 60947-5-3 EN 60204-1 ISO 13849-1 EN62061 EN 954-1 UL508
Safety Classification and Reliability Data:	
Switching Reliability	3.3 x 10 ⁶ operations at 100mA load up to Category 4 with Safety Relay
EN 954-1	up to PLe depending upon system architecture
ISO 13849-1	up to SIL3 depending upon system architecture
EN 62061	8 cycles per hour / 24 hours per day / 365 days
Safety Data - Annual Usage	2.52 x 10 ⁻⁸
PFHd	47 years
Proof Test Interval (Life)	470 years
MTTFd	24V.dc 0.2 A Max. Rating
Safety Channel 1 NC	24V.dc 0.2 A Max. Rating
Safety Channel 2 NC	24V.dc 0.2 A Max. Rating
Safety Channel 3 NO	24V.dc 0.2 A Max. Rating
Minimum switched current	10V. dc 1mA
Dielectric withstand	250V.ac
Insulation Resistance	100 Mohms
Recommended setting gap	5mm
Switching Distance:	Sao 8mm Close
(Target to target)	Sar 20mm Open
Tolerance to misalignment	5mm in any direction from 5mm setting gap
Switching frequency	1.0 Hz maximum
Approach speed	200mm/m. to 1000mm/s.
Body Material	UL approved polyester
Temperature Range	-25 +80C.
Enclosure Protection	IP67 (NEMA 6)
Shock Resistance	IEC 68-2-27 11ms 30g
Vibration Resistance	IEC 68-2-6 10-55 Hz. 1mm
Cable Type	PVC 8 core 6mm O.D.
Mounting Bolts	2 x M5 Tightening torque 1.0 Nm
Mounting Position	Any

Sales Number	Type	Conduit or cable exit	Circuits
120001	Idecode KPC	Pre-wired 2m. End	2NC 1NO
120002	Idecode KPC	Pre-wired 5m. End	2NC 1NO
120003	Idecode KPC	Pre-wired 10m. End	2NC 1NO
120004	Idecode KPC	Pre-wired 2m. Left	2NC 1NO
120005	Idecode KPC	Pre-wired 5m. Left	2NC 1NO
120006	Idecode KPC	Pre-wired 10m. Left	2NC 1NO
120007	Idecode KPC	Pre-wired 2m. Right	2NC 1NO
120008	Idecode KPC	Pre-wired 5m. Right	2NC 1NO
120009	Idecode KPC	Pre-wired 10m. Right	2NC 1NO
120012	Idecode KPC	QC M12 8 way 150mm End	2NC 1NO