

ACCESSORIES: 1/8 MANIFOLDS FOR SERIES 70 PNV-SOV VALVES

MANIFOLD WITH 2 TO 7 POSITIONS + FITTINGS

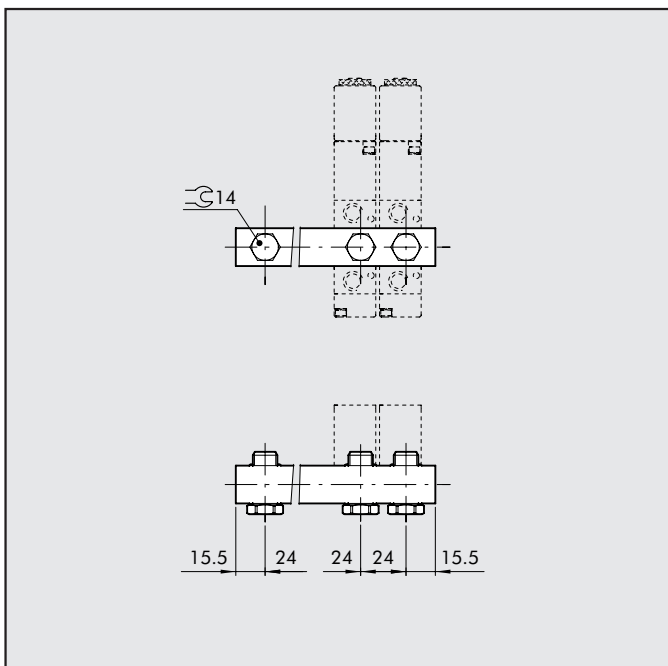

Code	Abbrev.	Weight [g]
0221000200	CSA-18-02	70
0221000300	CSA-18-03	99
0221000400	CSA-18-04	131
0221000500	CSA-18-05	162
0221000600	CSA-18-06	192
0221000700	CSA-18-07	229

BRACKET SET H30

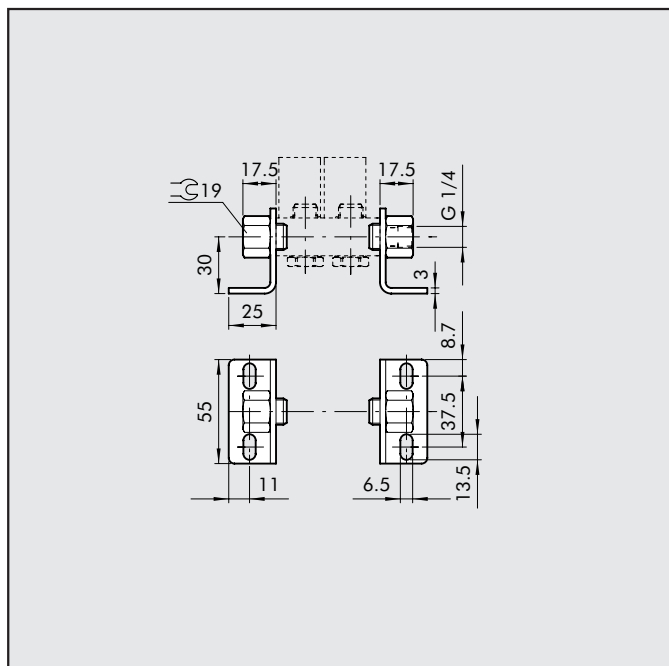

Code	Description	Weight [g]
0221000192	CSA-18-OE	181

BRACKET SET H60

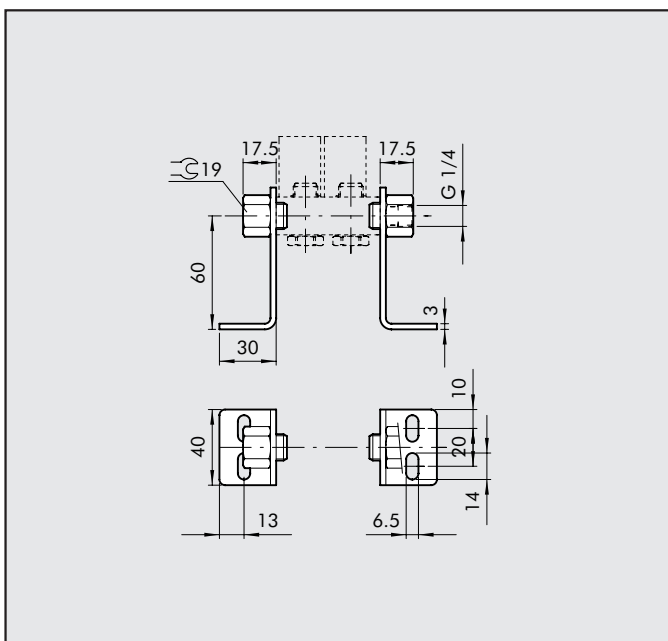

Code	Abbrev.	Weight [g]
0221000191	CSA-18-OC	213

BRACKET SET H120

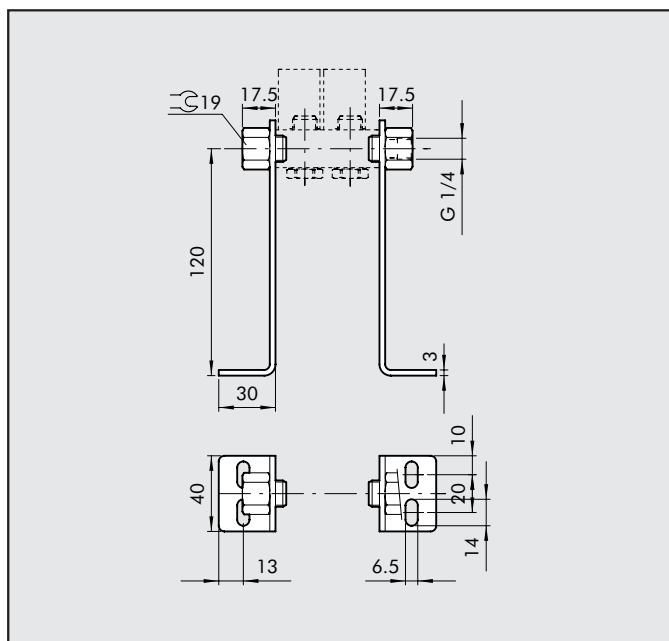

Code	Description	Weight [g]
0221000190	CSA-18-OO	309

ACCESSORIES: 1/4 MANIFOLDS FOR SERIES 70 PNV-SOV VALVES

MANIFOLD WITH 2 TO 7 POSITIONS + FITTINGS

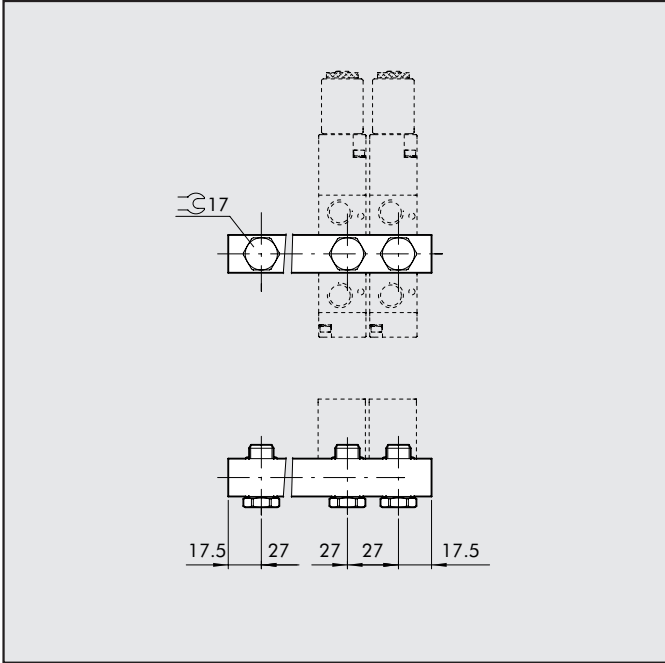

Code	Abbrev.	Weight [g]
0222000200	CSA-14-02	89
0222000300	CSA-14-03	131
0222000400	CSA-14-04	174
0222000500	CSA-14-05	213
0222000600	CSA-14-06	252
0222000700	CSA-14-07	328

BRACKET SET H30

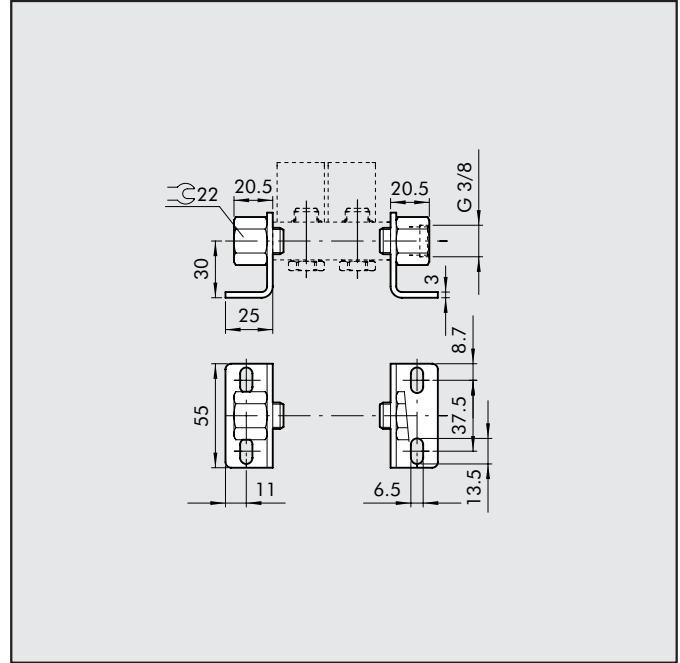

Code	Description	Weight [g]
0222000192	CSA-14-OE	209

BRACKET SET H60

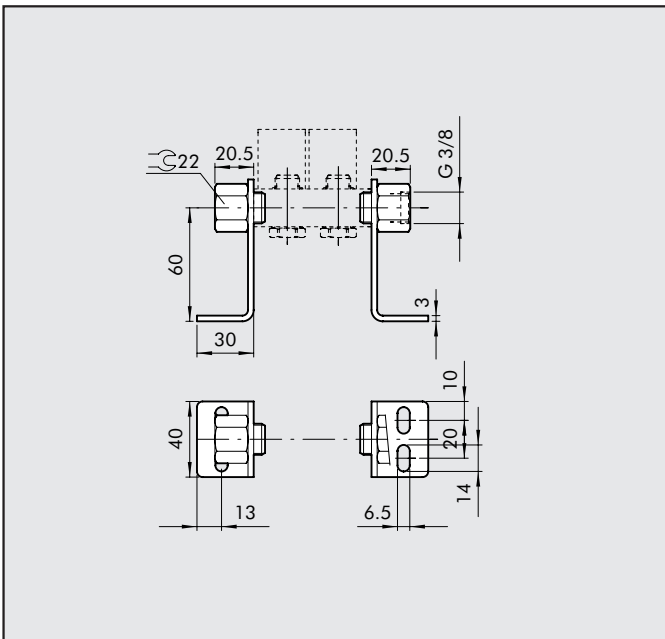

Code	Abbrev.	Weight [g]
0222000191	CSA-14-OC	242

BRACKET SET H120

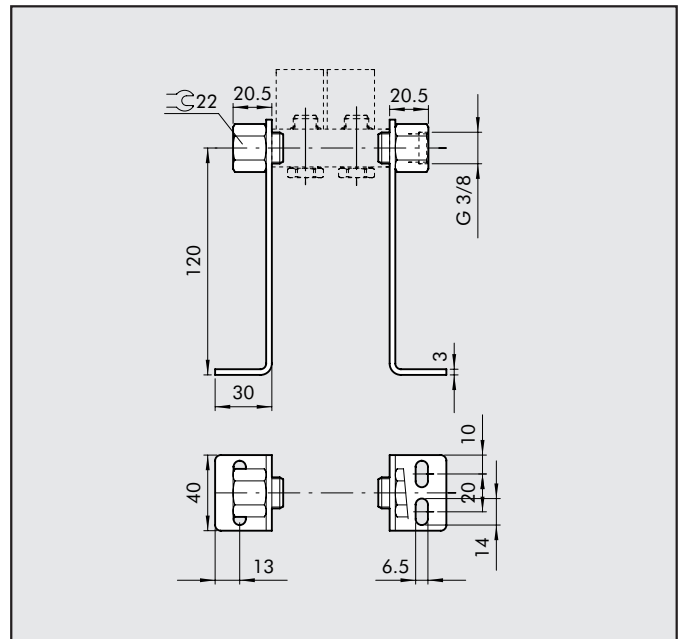

Code	Description	Weight [g]
0222000190	CSA-14-OO	338

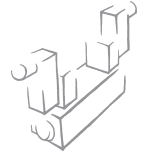

ACCESSORIES: MANIFOLD BASES FOR SERIES 70 PNV-SOV VALVES

MODULAR BASES FOR SERIES 70 SOV-PNV VALVES

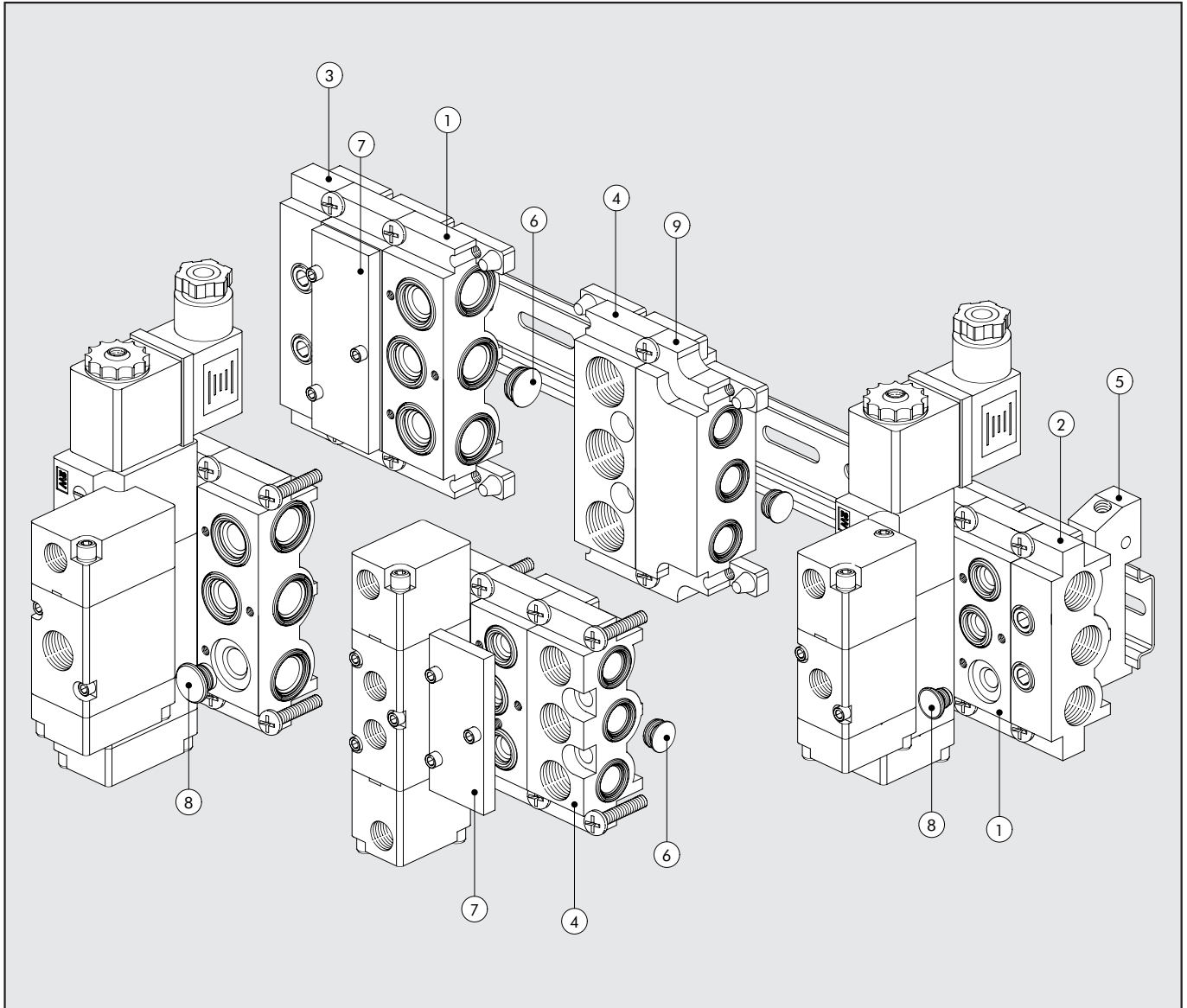

2

ORDERING CODES		1/8"		1/4"	
Reference	Description	Code	Abbrev.	Code	Abbrev.
①	Modular manifold base	0226004150	COMP. MANIFOLD 1/8"	0226005150	MANIFOLD 1/4"
②	End plate without OR	0226004201	T S/Z OR 1/8"	0226005201	T S/Z OR 1/4"
③	End plate with OR	0226004200	MAN. INPUT T. 1/8"	0226005200	MAN. INPUT T. 1/4"
④	Intermediate part for upper feed	0226004300	SUP. SUPPLY SWITCH 1/8"	0226005300	SUP. SUPPLY SWITCH 1/4"
⑤	Adapter Ω	0226004600	ADT Ω 1/8"	0226005600	ADT Ω 1/4"
⑥	Intermediate diaphragm	0226004000	COMP. DIA. 1/8"	0226005000	COMP. DIA. 1/4"
⑦	Blanking plate	0226004500	COMP. PCS 1/8"	0226005500	COMP. PCS 1/4"
⑧	3/2 cap	0226004001	COMP. PLUG 3/2 1/8"	0226005001	COMP. PLUG 3/2 1/4"
⑨	Dimensional adapter	0226006600	COMP. ADAPT. 1/8", 1/4"	-	-

MODULAR BASE 1/8"

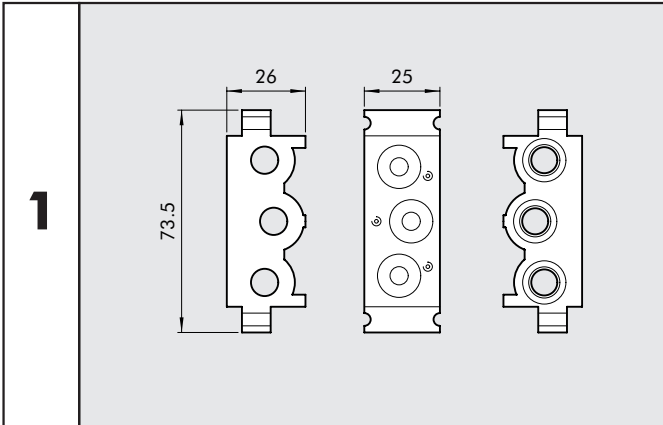

Code	Abbrev.	Weight [g]
0226004150	COMP. MANIFOLD 1/8"	110

MODULAR BASE 1/4"

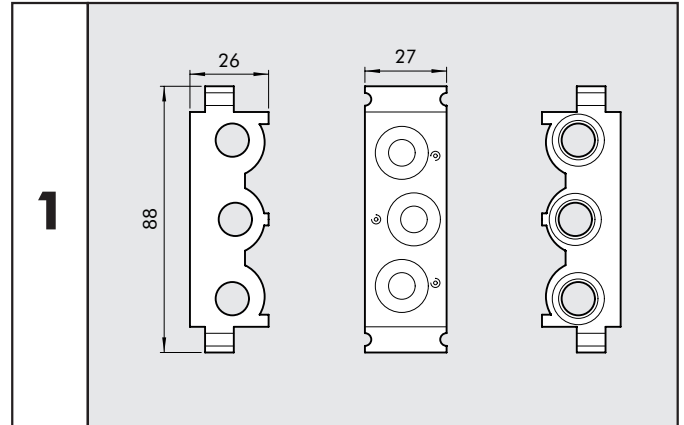

Code	Abbrev.	Weight [g]
0226005150	COMP. MANIFOLD 1/4"	131

END PLATE WITHOUT OR 1/8"

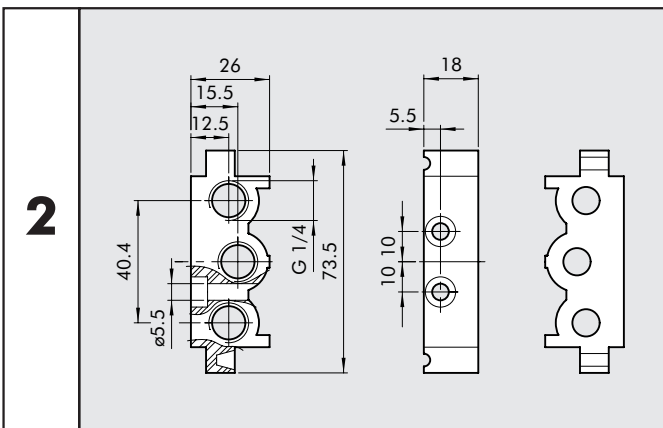

Code	Abbrev.	Weight [g]
0226004201	T. S/ZA OR 1/8"	52

END PLATE WITHOUT OR 1/4"

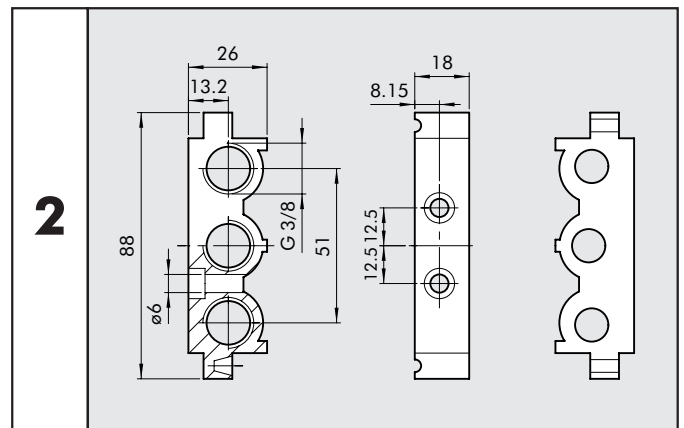

Code	Abbrev.	Weight [g]
0226005201	T. S/ZA OR 1/4"	57

END PLATE WITH OR 1/8"

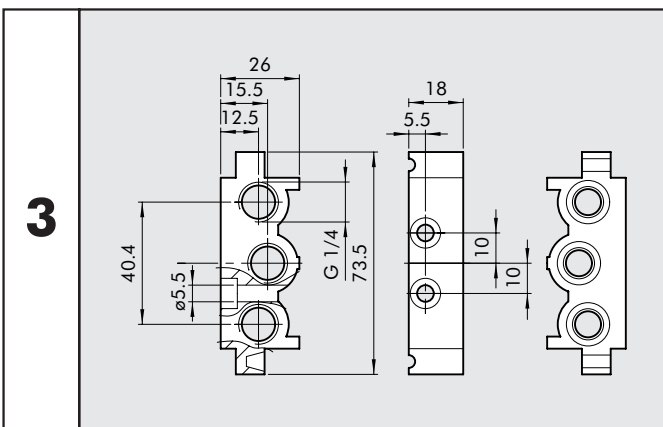

Code	Abbrev.	Weight [g]
0226004200	MAN. INPUT T. 1/8"	74

END PLATE WITH OR 1/4"

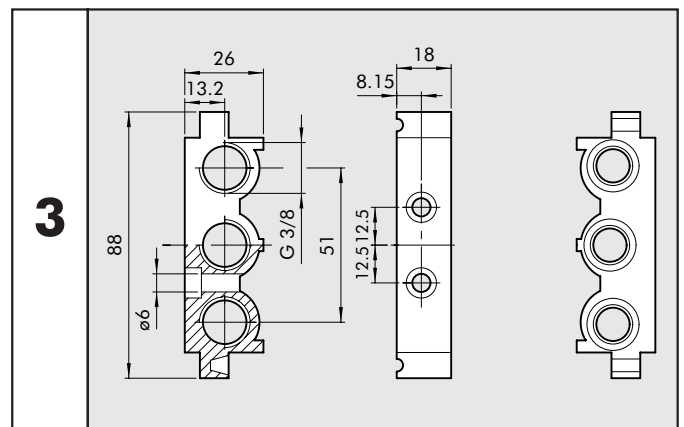

Code	Abbrev.	Weight [g]
0226005200	MAN. INPUT T. 1/4"	80

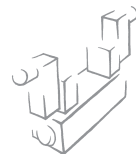

INTERMEDIATE PART FOR UPPER FEED 1/8"

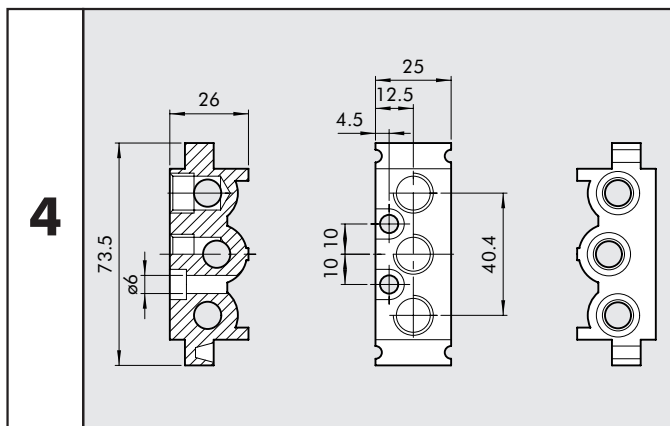

Code	Abbrev.	Weight [g]
0226004300	SUP. SUPPLY SW. 1/8"	93

INTERMEDIATE PART FOR UPPER FEED 1/4"

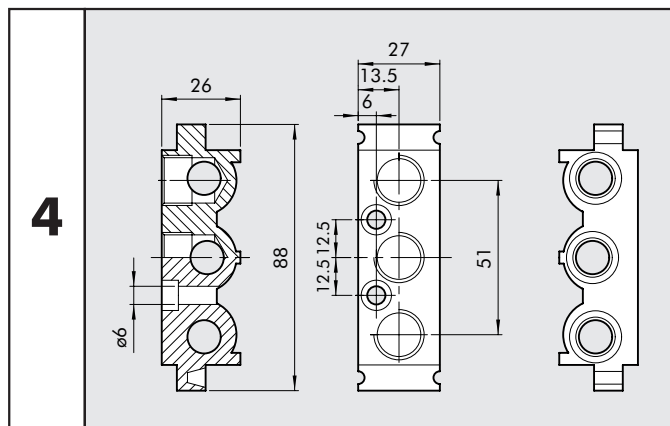

Code	Abbrev.	Weight [g]
0226005300	SUP. SUPPLY SW. 1/4"	109

2

ADAPTER FOR Ω BAR BASES 1/8"

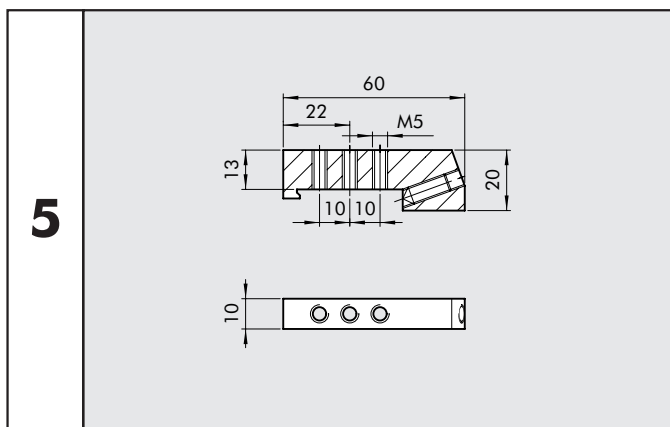

Code	Abbrev.	Weight [g]
0226004600	ADT Ω 1/8"	46
N.B. ALSO FOR MULTIPLE BASES		

ADAPTER FOR Ω BAR BASES 1/4"

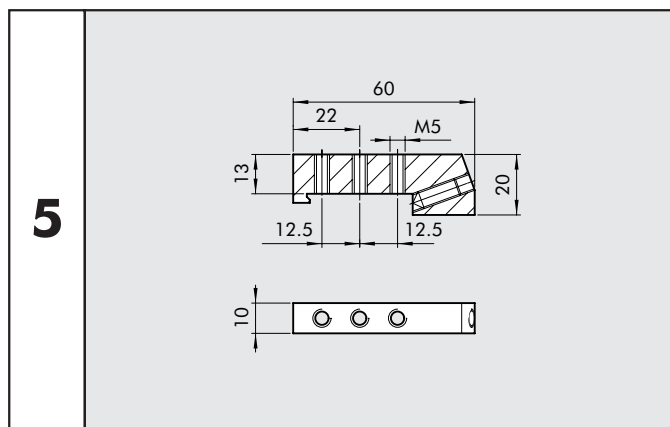

Code	Abbrev.	Weight [g]
0226005600	ADT Ω 1/4"	46
N.B. ALSO FOR MULTIPLE BASES		

INTERMEDIATE DIAPHRAGM 1/8"

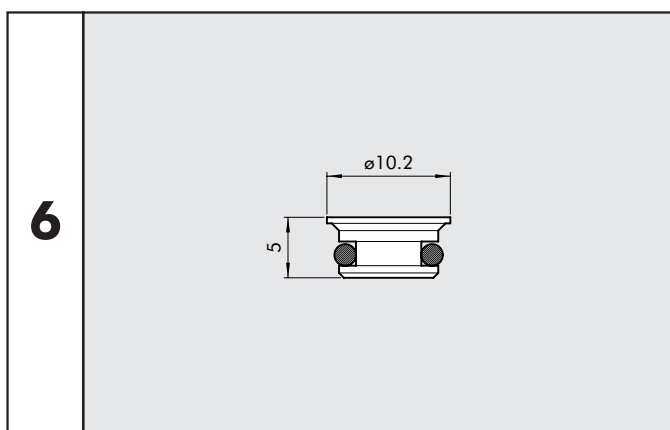

Code	Abbrev.	Weight [g]
0226004000	COMP. DIA. 1/8"	2

INTERMEDIATE DIAPHRAGM 1/4"

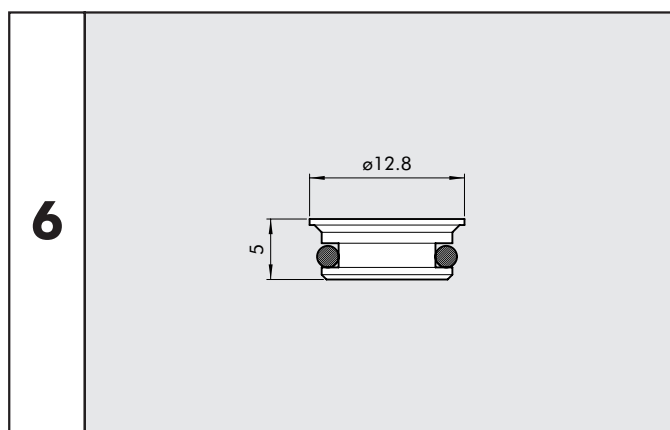

Code	Abbrev.	Weight [g]
0226005000	COMP. DIA. 1/4"	3

BLANKING PLATE FOR UNUSED POSITIONS 1/8"

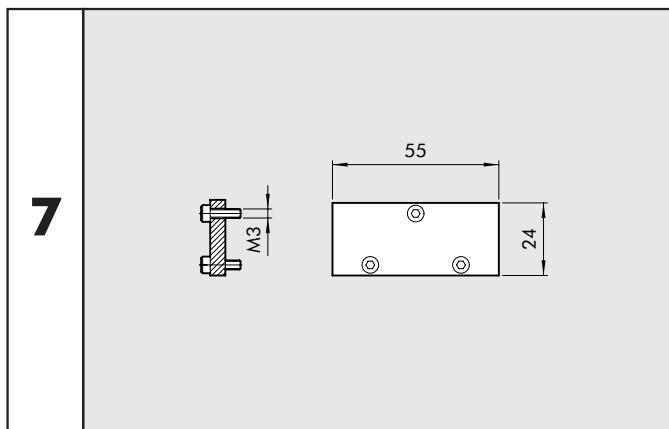

Code	Abbrev.	Weight [g]
0226004500	COMP. PCS 1/8"	23

BLANKING PLATE FOR UNUSED POSITIONS 1/4"

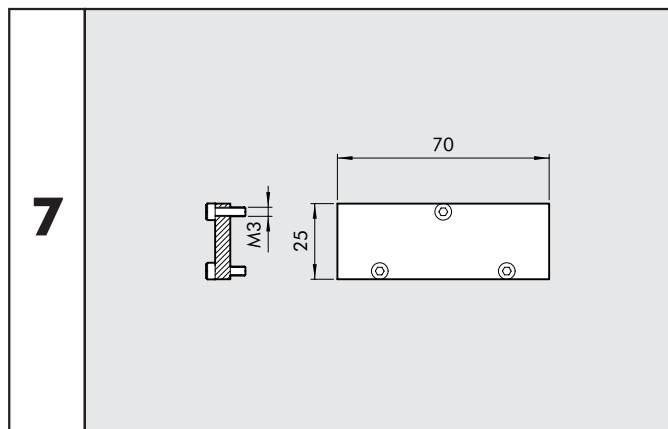

Code	Abbrev.	Weight [g]
0226005500	COMP. PCS 1/4"	29

PLUG FOR 3/2 1/8"

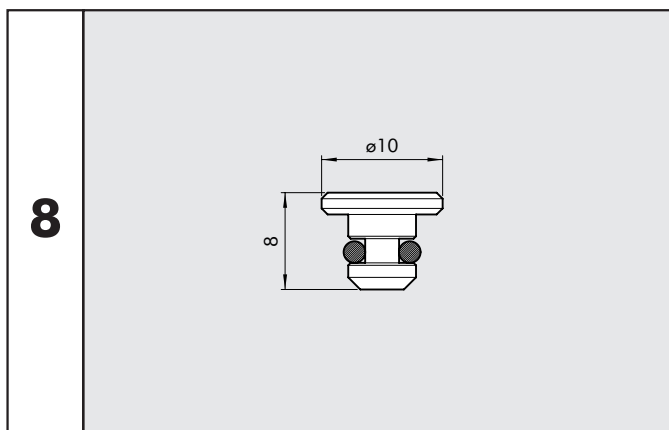

Code	Abbrev.	Weight [g]
0226004001	COMPLETE PLUG 3/2 1/8"	2

PLUG FOR 3/2 1/4"

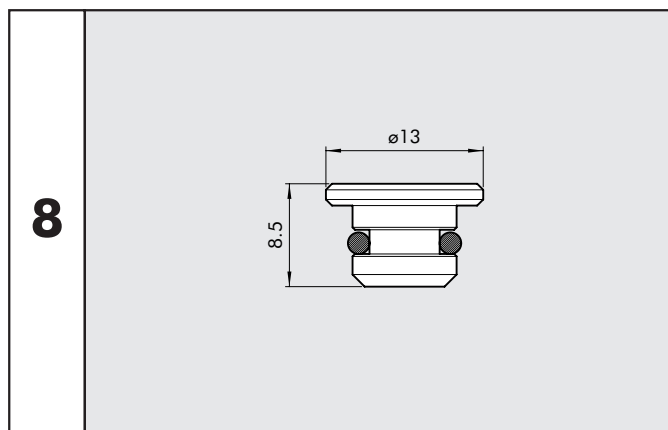

Code	Abbrev.	Weight [g]
0226005001	COMPLETE PLUG 3/2 1/4"	4

DIMENSIONAL ADAPTER 1/8" – 1/4"

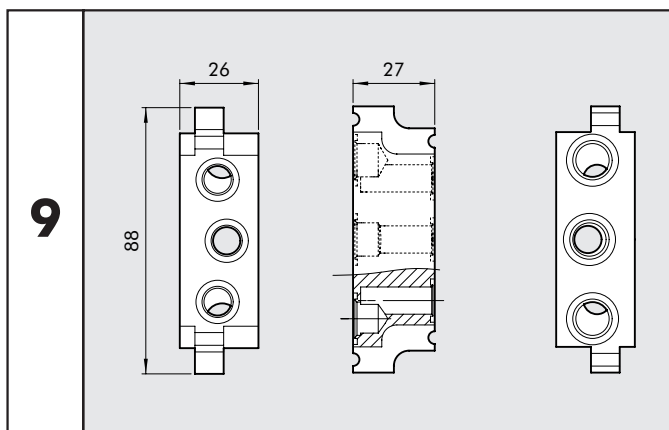

Code	Abbrev.	Weight [g]
0226006600	COMP. ADAPT. 1/8", 1/4"	177

NOTES

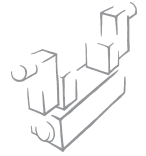

ACCESSORIES: MULTIPLE BASES FOR SERIES 70 PNV-SOV VALVES

MULTIPLE BASES 1/8"

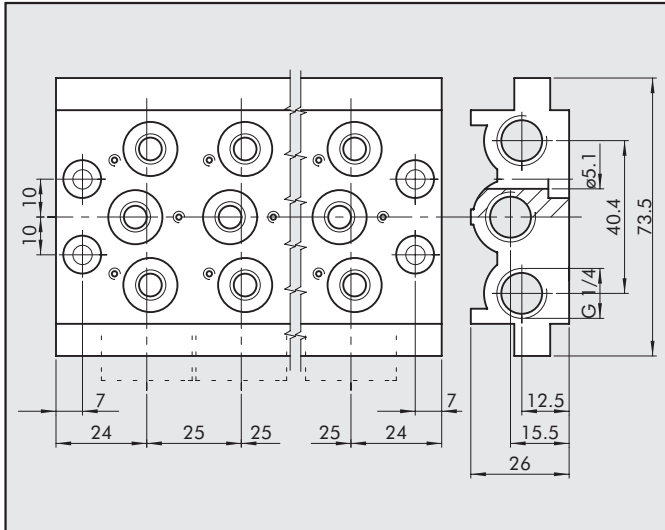

MULTIPLE BASES 1/4"

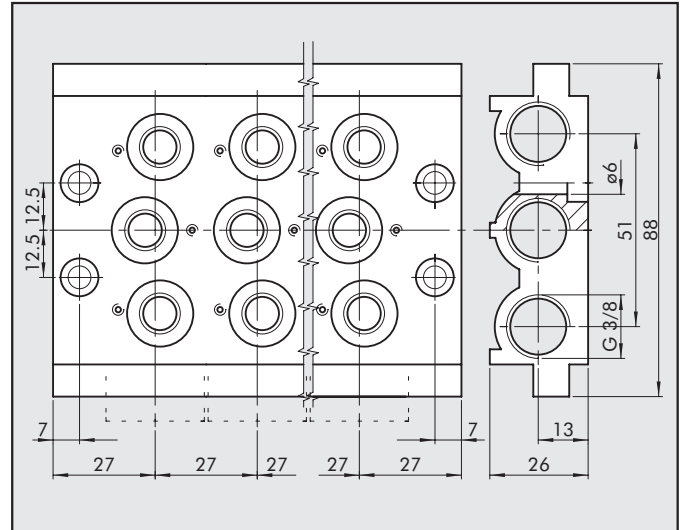

2

Code	Description	Abbrev.	Weight [g]
0223000201	2-POSITION BASE	CVM-18-02	236
0223000301	3-POSITION BASE	CVM-18-03	321
0223000401	4-POSITION BASE	CVM-18-04	407
0223000501	5-POSITION BASE	CVM-18-05	494
0223000601	6-POSITION BASE	CVM-18-06	587
0223000701	7-POSITION BASE	CVM-18-07	711
0223000801	8-POSITION BASE	CVM-18-08	760
0223000901	9-POSITION BASE	CVM-18-09	842
0223001001	10-POSITION BASE	CVM-18-10	923

Code	Description	Abbrev.	Weight [g]
0224000201	2-POSITION BASE	CVM-14-02	296
0224000301	3-POSITION BASE	CVM-14-03	406
0224000401	4-POSITION BASE	CVM-14-04	515
0224000501	5-POSITION BASE	CVM-14-05	624
0224000601	6-POSITION BASE	CVM-14-06	733
0224000701	7-POSITION BASE	CVM-14-07	845
0224000801	8-POSITION BASE	CVM-14-08	956
0224000901	9-POSITION BASE	CVM-14-09	1055
0224001001	10-POSITION BASE	CVM-14-10	1086

GASKET KIT

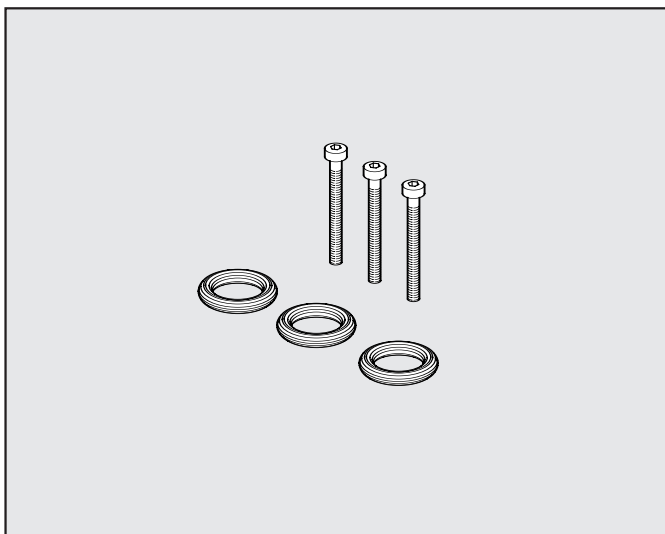

Code	Description	Weight [g]
0226004701	GASKET KIT FOR 1/8" BASE	5
0226005701	GASKET KIT FOR 1/4" BASE	5

NOTES

Blank area for notes.