

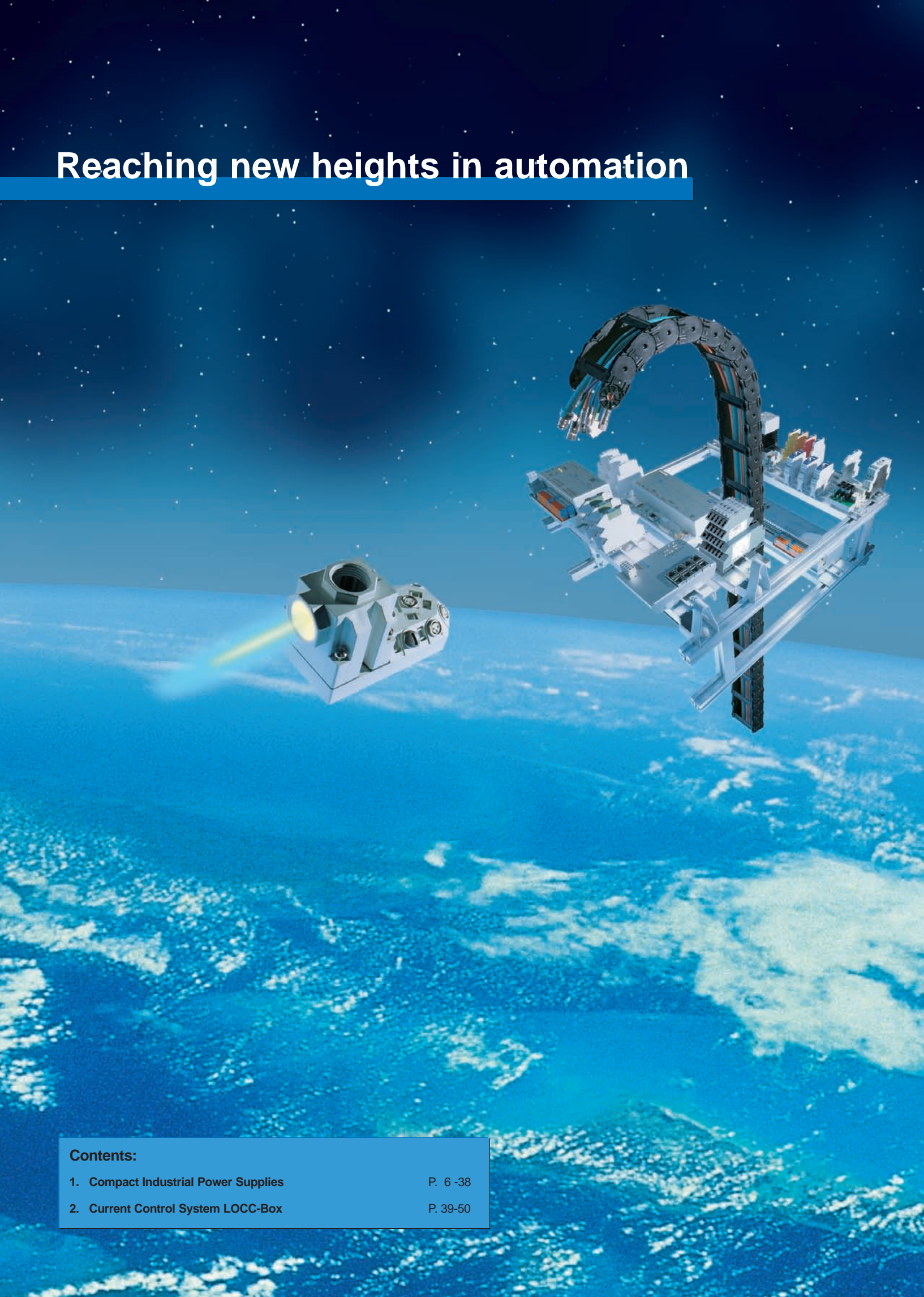

■ Automation Solutions

Compact Industrial Power Supplies

Reaching new heights in automation



Contents:

- | | |
|--------------------------------------|----------|
| 1. Compact Industrial Power Supplies | P. 6 -38 |
| 2. Current Control System LOCC-Box | P. 39-50 |

Installation Solutions



Cabinet Solutions



Automation Solutions



OEM Solutions



Transportation Solutions



We have been developing and manufacturing electronic and electrical engineering solutions for controls and installations for more than 50 years.

Our basic concept as system suppliers, providing a comprehensive and well-matched product range with which we can generate innovative and customized solutions for our customers, has stood the test of time.

The close relationship between product development and customer requirements allows Lutze continuously to improve and develop our products for the various markets.

Lutze systems comply with the highest industrial standards; Lutze solutions mean improvement and innovation.

Our solutions include components and concepts suitable for almost any control application. For more information on our solutions, please visit www.lutze.com.



Systematic Technology

Compact Industrial Power Supplies • Overview



No. 1

No. 2

No. 3

No. 4

No. 5

No. 6

DC voltage supply, regulated

Rated power										Input			Output					Connection			Part-Nr.	Type	Page	No.				
10 W	15 W	18 W	30 W	50 W	60 W	70 W	93 W	120 W	240 W	480 W	720 W	960 W	1-phasic	2-phasic	3-phasic	5 V	12 V	15 V	24 V	48 V					Screw terminal pluggable	Screw terminal	Spring terminal	
•													•								•			728761	DRA10-05A	6	1	
•													•				0,84A					•			728766	DRA10-12A	6	1
•													•				2A					•			722761	DRA10-5	7	1
•													•				0,84A					•			722766	DRA10-12	7	1
•													•					0,67A				•			722773	DRA10-15	7	1
•													•					0,42A				•			722751	DRA10-24	7	1
•	•												•									•			722762	DRA18-5	8	1
•	•												•				3A					•			728762	DRA18-5A	8	1
•	•												•				1,5A					•			722767	DRA18-12	9	1
•	•												•					1,2A				•			722774	DRA18-15	9	1
•	•												•						0,75A			•			722752	DRA18-24	9	1
•	•	•											•				6A					•			722763	DRA30-5A	10	2
•	•	•											•				2,5A					•			722768	DRA30-12A	10	2
•	•	•											•					1,25A				•			722753	DRA30-24A	10	2
•	•	•											•						0,63A			•			722775	DRA30-48A	10	2
•	•	•											•				6A					•			728763	DRA30-5	11	2
•	•	•											•				2,5A					•			728768	DRA30-12	11	2
•	•	•											•					1,25A				•			728753	DRA30-24	11	2
•	•	•											•						0,63A			•			728775	DRA30-48	11	2
•	•	•											•					1,2A				•			722790	CPSFB1-30-24	12	3
•	•	•											•					1,2A				•			722787	CPSF1-30-24	13	4
•	•	•											•					2,2A				•			722788	CPSF1-50-24	13	4
•	•	•											•				10A					•			722764	DRA60-5A	14	2
•	•	•											•				10A					•			728764	DRA60-5	14	2
•	•	•											•				5A					•			728769	DRA60-12	15	2
•	•	•											•					2,5A				•			728754	DRA60-24	15	2
•	•	•											•						1,25A			•			728776	DRA60-48	15	2
•	•	•											•				5A					•			722769	DRA60-12A	16	2
•	•	•											•					2,5A				•			722754	DRA60-24A	16	2
•	•	•											•						1,25A			•			722776	DRA60-48A	16	2
•	•	•											•					3,0A				•			722789	CPSF1-70-24	17	4
•	•	•											•					3,8A				•			722757	DRAN120-24AL	18	5
•	•	•											•				10A					•			722770	DRAN120-12B	19	5
•	•	•											•					5A				•			722758	DRAN120-24B	19	5
•	•	•											•						2,5A			•			722777	DRAN120-48B	19	5
•	•	•											•					5A				•			722783	CPSB1-120-24R	20	6
•	•	•											•						2,5A			•			722784	CPSB1-120-48R	20	6
•	•	•											•	•				5A				•			722983	CPSB2-120-24	22	6

Compact Industrial Power Supplies • Overview



No. 7



No. 8



No. 9



No. 10



No. 11



No. 12

DC voltage supply, regulated

Rated power		Input			Output					Connection			Part-Nr.	Type	Page	No.												
10 W	15 W	18 W	30 W	50 W	60 W	70 W	93 W	120 W	240 W	480 W	720 W	960 W	1-phasing	2-phasing	3-phasing	5 V	12 V	15 V	24 V	48 V	72 V	Screw terminal pluggable	Screw terminal	Spring terminal				
								•					•									•			722794	CPS65-120-24	21	7
								•							•							•			722803	WRA 120-24	23	8
								•														•			722759	DRA240-24B	24	8
								•														•			722778	DRA240-48B	24	8
								•														•			722781	DRA240-24A	24	8
								•														•			722785	CPSB1-240-24R	25	6
								•														•			722786	CPSB1-240-48R	25	6
								•							•							•			722984	CPSB2-240-24	26	6
								•														•			722799	CPSB3-240-24	27	9
								•														•			722804	WRA240-24	28	8
								•														•			722808	WRA240-48	28	8
								•														•			722782	DRA480-24A	29	10
								•														•			722779	DRA480-48A	29	10
								•														•			722986	CPSB1-480-24R	30	9
								•														•			722805	WRA480-24	30	10
								•														•			722809	WRA480-48	30	10
								•														•			722800	CPSB3-500-24	31	9
								•														•			722802	CPSB3-720-24	33	9
								•														•			722806	WRA960-24	32	11
								•														•			722810	WRA960-48	32	11
								•														•			722811	CPSB3-960-24	35	9
								•														•			722812	CPSB3-960-48	35	9
								•														•			722813	CPSB3-960-72	35	9

DC voltage supply, unregulated

Rated Power		Input			Output					Connection			Part-Nr.	Type	Page	No.												
60 W	72 W	120 W	144 W	240 W	360 W	AC 115 V (104...196 V)	AC 230 V (207...244 V)	AC 400 V (360...424 V)	5 V	12 V	15 V	24 V	48 V	Screw terminal pluggable	Screw terminal	Spring terminal												
•						•	•	•						•				722962	NG 24/2,5-2962	37	12							
	•					•	•	•						•				722963	NG 24/5-2963	37	12							
		•				•	•	•						•				722972	NG24/10-2972	37	12							
			•			•	•	•						•				722973	NG24/15-2973	37	12							
				•		•	•	•						•				722620	NG24/3-2620 SI	38	12							
					•	•	•	•						•				722621	NG24/6-2621 SI	38	12							
						•	•	•						•				722622	NG24/10-2622 SI	38	12							

Redundant Manager

Current	Input/Output	Monitoring			Output	Connection			Part-Nr.	Type	Page	No.
		Under Voltage	Over Voltage	Potential free Status Output		Screw terminal pluggable	Screw terminal	Spring terminal				
• 20 A	DC 24 V (21...28 V)	•	•	•	20A	•	•	•	722962	DRP 20-24	36	2

Power supply - regulated, 10 W

Primary switchmode power supply, Single-phase, Class 2

Input: Wide range input AC 90 V - 265 V; DC 120 V - 370 V

Output: 5 V / 12 V - adjustable



Dimensions

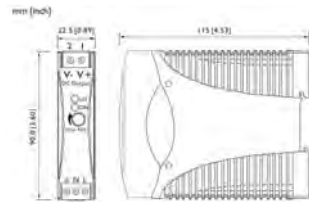

PIN assignment

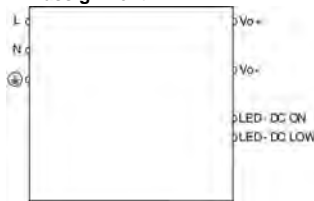

Derating

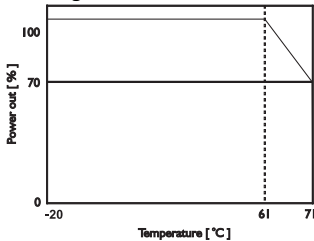

Parallel mode

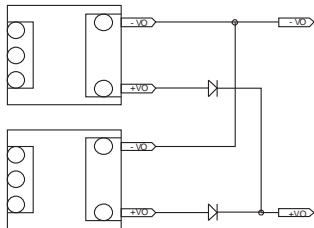

Description	Part-No.	Type	PU
Screw terminal			
Output voltage/current	DC 5 V; 2 A	728761	DRA 10-05A
	DC 12 V; 0.84 A	728766	DRA 10-12A

Input	DRA 10-05A	DRA 10-12A
Nominal voltage		AC 100–240 V
Operation voltage range	AC 90–265 V / DC 120–370 V	
Line frequency	47 – 63 Hz	
Rated current	U _i = AC 115 V: 120 mA / U _i = AC 230 V: 70 mA	
Inrush current	U _i = AC 115 V: 10 A / U _i = AC 230 V: 18 A	
Internal fuse	T2 A / AC 250 V	
External fuse	Mini-circuit breaker: B 3 A	
Power Factor Correction P.F.C.	–	

Output	DRA 10-05A	DRA 10-12A
Rated voltage output	DC 5 V	DC 12 V
Rated current output	2 A	0.84 A
Max. output current	–	
Peak output current	–	
Voltage trim range	4.5–5.75 V	10.8–13.8 V
Accuracy	±1 %	
Line regulation	±1 %	
Load regulation	±2 %	
Rise time	1 s	
Temperature coefficient	±0.03 % / °C	
Ripple & Noise	<50 mV	
Hold up time	V _{in} = 115 V: 25 ms / V _{in} = 230 V: 100 ms	
Status indication DC ON LED green	≥4.5 V	≥10.8 V
Status indication DC LOW LED red	<3.75–4.50 V	<9–10.8 V
Parallel mode	with external diodes	
Efficiency	73 %	75 %
Low power loss	4 A (AC 230 V)	3.4 A (AC 230 V)
Rated over load protection	110–135 %	
Over voltage protection	125–145 %	
Short circuit characteristics	Hiccup-mode	

General	DRA 10-05A	DRA 10-12A
Switching frequency	approx. 100 kHz	
Insulation voltage input/output	AC 3.0 kV _{eff}	
Insulation voltage input / ground	AC 1.5 kV _{eff}	
Insulation voltage output / ground	–	
Insulation resistance at DC 500 V	100 MΩ	
Operation temperature range	-20 °C – 70 °C (derating)	
Derating	-3% / °C starting at 61° C	
Storage temperature range	-25 °C – 85 °C	
M.T.B.F.	801000 h	803000 h
Relative humidity	20–95 % RH	
Dimensions (w x h x d) in mm	22.5 x 90.0 x 115.0	
Cooling	Air convection	
Housing material	Plastic	
Field installation	rail TS 35 (EN 50022)	
Application height	2000 m	
Installation position	vertical	
Protection class	IP 20	
Overvoltage category	II	
Pollution degree	2	
Protection class	2	
Weight (kg/piece)	0.120	
Termination	Screw terminal: 0.2–2.0 mm ²	
Approvals	UL: UL 508 listed; cUL: UL 60950-1, UL 1310 Class 2; TÜV: EN 60950-1, CE: EN 50081-1 / EN 55022 Class B, EN 61000-3-2, EN 601000-3-3, EN 50082-1 / EN 55024	

Monitoring	DRA 10-05A	DRA 10-12A
DC ON Control (Rdy)	LED green/red	
Switching voltage	–	
Switching current	–	
Switching capacity	–	
Insulation voltage	–	

Power supply - regulated, 10 W

Primary switchmode power supply, Single-phase, Class 2
Input: Wide range input AC 90 V - 265 V; DC 120 V - 370 V
Output: 5 V / 12 V / 15 V / 24 V - adjustable



Dimensions

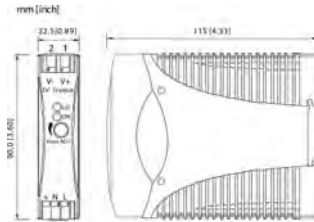

PIN assignment



Derating

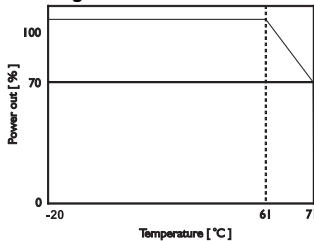

Parallel mode

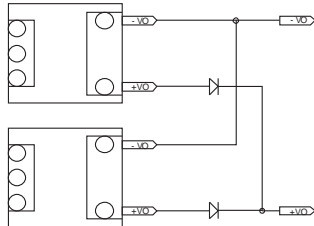

Description	Part-No.	Type	PU	
Spring terminal				
Output voltage/current	DC 5 V; 2 A	722761	DRA 10-05	1
	DC 12 V; 0.84 A	722766	DRA 10-12	1
	DC 15 V; 0.67 A	722773	DRA 10-15	1
	DC 24 V; 0.42 A	722751	DRA 10-24	1

Input	DRA 10-05	DRA 10-12	DRA 10-15	DRA 10-24
Nominal voltage	AC 100–240 V			
Operation voltage range	AC 90–265 V / DC 120–370 V			
Line frequency	47 – 63 Hz			
Rated current	U _i = AC 115 V: 120 mA / U _i = AC 230 V: 70 mA			
Inrush current	U _i = AC 115 V: 10 A / U _i = AC 230 V: 18 A			
Internal fuse	T2 A / AC 250 V			
External fuse	Mini-circuit breaker: B 3 A			
Power Factor Correction P.F.C.	–			

Output	DRA 10-05	DRA 10-12	DRA 10-15	DRA 10-24
Rated voltage output	DC 5 V	DC 12 V	DC 15 V	DC 24 V
Rated current output	2 A	0.84 A	0.67 A	0.42 A
Max. output current	–			
Peak output current	–			
Voltage trim range	4.5–5.75 V	10.8–13.8 V	13.5–17.25 V	21.6–28.8 V
Accuracy	±1 %			
Line regulation	±1 %			
Load regulation	±2 %			
Rise time	1 s			
Temperature coefficient	±0.03 % / °C			
Ripple & Noise	<50 mV			
Hold up time	V _{in} = 115 V: 25 ms / V _{in} = 230 V: 100 ms			
Status indication DC ON LED green	≥4.5 V	≥10.8 V	≥13.5 V	≥21.6 V
Status indication DC LOW LED red	<3.75–4.50 V	<9–10.8 V	<11.25–13.5 V	<18–21.6 V
Parallel mode	with external diodes			
Efficiency	73 %	75 %	76 %	77 %
Low power loss	4 A (AC 230 V)	3.4 A (AC 230 V)	3.3 A (AC 230 V)	2.8 A (AC 230 V)
Rated over load protection	110–135 %			
Over voltage protection	125–145 %			
Short circuit characteristics	Hiccup-mode			

General				
Switching frequency	approx. 100 kHz			
Insulation voltage input/output	AC 3.0 kV _{eff}			
Insulation voltage input / ground	AC 1.5 kV _{eff}			
Insulation voltage output / ground	–			
Insulation resistance at DC 500 V	100 MΩ			
Operation temperature range	-20 °C – 70 °C (derating)			
Derating	-3% / °C starting at 61 °C			
Storage temperature range	-25 °C – 85 °C			
M.T.B.F.	801000 h	803000 h	805000 h	808000 h
Relative humidity	20–95 % RH			
Dimensions (w x h x d) in mm	22.5 x 90.0 x 115.0			
Cooling	Air convection			
Housing material	Plastic			
Field installation	rail TS 35 (EN 50022)			
Application height	2000 m			
Installation position	vertical			
Protection class	IP 20			
Overvoltage category	II			
Pollution degree	2			
Protection class	2			
Weight (kg/piece)	0.120			
Termination	Spring terminal: 0.2–2.0 mm ²			
Approvals	UL: UL 508 listed; cUL: UL 60950-1, UL 1310 Class 2; TÜV: EN 60950-1, CE: EN 50081-1 / EN 55022 Class B, EN 61000-3-2, EN 61000-3-3, EN 50082-1 / EN 55024			

Monitoring	
DC ON Control (Rdy)	LED green/red
Switching voltage	–
Switching current	–
Switching capacity	–
Insulation voltage	–

Power supply - regulated, 15 W

Primary switchmode power supply, Single-phase, Class 2
Input: Wide range input AC 90 V - 265 V; DC 120 V - 370 V
Output: 5 V - adjustable



Dimensions

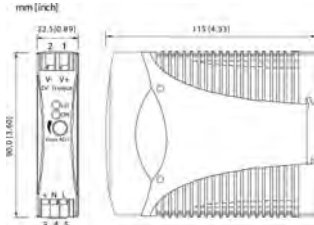

PIN assignment

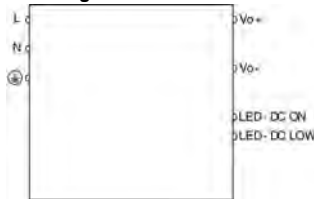

Derating

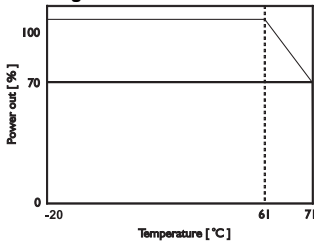

Parallel mode

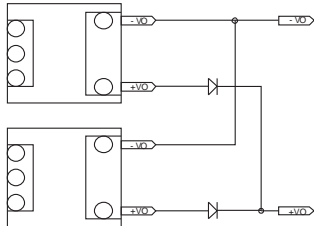

Description	Part-No.	Type	PU	
Screw terminal				
Output voltage/current	DC 5 V; 3 A	728762	DRA 18-05A	1
Spring terminal				
Output voltage/current	DC 5 V; 3 A	722762	DRA 18-05	1
Input				
	DRA 18-05A	DRA 18-05		
Nominal voltage		AC 100–240 V		
Operation voltage range		AC 90–265 V / DC 120–370 V		
Line frequency		47 – 63 Hz		
Rated current		U _i = AC 115 V: 170 mA / U _i = AC 230 V: 90 mA		
Inrush current		U _i = AC 115 V: 10 A / U _i = AC 230 V :18 A		
Internal fuse		T2 A / AC 250 V		
External fuse		Mini-circuit breaker: B 3 A		
Power Factor Correction P.F.C.		–		
Output				
Rated voltage output		DC 5 V		
Rated current output		3 A		
Max. output current		–		
Peak output current		–		
Voltage trim range		4.5–5.75 V		
Accuracy		±1 %		
Line regulation		±1 %		
Load regulation		±2 %		
Rise time		1 s		
Temperature coefficient		±0.03 % / °C		
Ripple & Noise		<50 mV		
Hold up time		U _i = 115 V: 20 ms / U _i = 230 V: 75 ms		
Status indication DC ON LED green		≥4.5 V		
Status indication DC LOW LED red		<3.75–4.50 V		
Parallel mode		with external diodes		
Efficiency		75 %		
Low power loss		5 A (AC 230 V)		
Rated over load protection		110–135 %		
Over voltage protection		125–145 %		
Short circuit characteristics		Hiccup-mode		
General				
Switching frequency		approx. 100 kHz		
Insulation voltage input/output		AC 3.0 kV _{eff}		
Insulation voltage input / ground		AC 1.5 kV _{eff}		
Insulation voltage output / ground		–		
Insulation resistance at DC 500 V		100 MΩ		
Operation temperature range		-20 °C – 70 °C (derating)		
Derating		-3% / °C starting at 60 °C		
Storage temperature range		-25 °C – 85 °C		
M.T.B.F.		795000 h		
Relative humidity		20–95 % RH		
Dimensions (w x h x d) in mm		22.5 x 90.0 x 115.0		
Cooling		Air convection		
Housing material		Plastic		
Field installation		rail TS 35 (EN 50022)		
Application height		2000 m		
Installation position		vertical		
Protection class		IP 20		
Overvoltage category		II		
Pollution degree		2		
Protection class		2		
Weight (kg/piece)		0.150		
Termination		Screw terminal: 0.2–2.0 mm ² Spring terminal: 0.2–2.0 mm ²		
Approvals		UL: UL 508 listed; cUL: UL 60950-1, UL 1310 Class 2; TÜV: EN 60950-1, CE: EN 50081-1 / EN 55022 Class B, EN 61000-3-2, EN 61000-3-3, EN 50082-1 / EN 55024		
Monitoring				
DC ON Control (Rdy)		LED green/red		
Switching voltage		–		
Switching current		–		
Switching capacity		–		
Insulation voltage		–		

Power supply - regulated, 18 W

Primary switchmode power supply, Single-phase, Class 2
Input: Wide range input AC 90 V - 265 V; DC 120 V - 370 V
Output: 12 V / 15 V / 24 V - adjustable



Dimensions

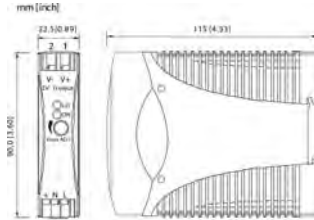

PIN assignment



Derating

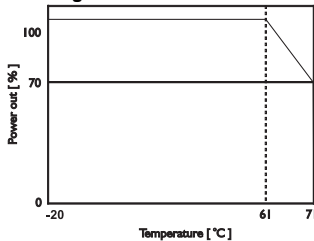

Parallel mode

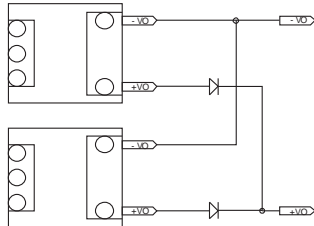

Description	Part-No.	Type	PU	
Spring terminal				
Output voltage/current	DC 12 V; 1.5 A	722767	DRA 18-12	1
	DC 15 V; 1.2 A	722774	DRA 18-15	1
	DC 24 V; 0.75 A	722752	DRA 18-24	1

Input	DRA 18-12	DRA 18-15	DRA 18-24
Nominal voltage		AC 100–240 V	
Operation voltage range	AC 90–265 V / DC 120–370 V		
Line frequency	47 – 63 Hz		
Rated current	U _I = AC 115 V: 200 mA / U _I = AC 230 V: 110 mA		
Inrush current	U _I = AC 115 V: 10 A / U _I = AC 230 V: 18 A		
Internal fuse	T2 A / AC 250 V		
External fuse	Mini-circuit breaker: B 3 A		
Power Factor Correction P.F.C.	–		

Output	DRA 18-12	DRA 18-15	DRA 18-24
Rated voltage output	DC 12 V	DC 15 V	DC 24 V
Rated current output	1.5 A	1.2 A	0.75 A
Max. output current	–		
Peak output current	–		
Voltage trim range	10.8–13.8 V	13.5–17.25 V	21.6–28.8 V
Accuracy	±1 %		
Line regulation	±1 %		
Load regulation	±2 %		
Rise time	1 s		
Temperature coefficient	±0.03 % / °C		
Ripple & Noise	<50 mV		
Hold up time	U _I = 115 V: 20 ms / U _I = 230 V: 75 ms		
Status indication DC ON LED green	≥10.8 V	≥13.5 V	≥21.6 V
Status indication DC LOW LED red	<9–10.8 V	<11.25–13.5 V	<18–21.6 V
Parallel mode	with external diodes		
Efficiency	77 %		
Low power loss	4.65 A (AC 230 V)	4.25 A (AC 230 V)	4.45 A (AC 230 V)
Rated over load protection	110–135 %		
Over voltage protection	125–145 %		
Short circuit characteristics	Hiccup-mode		

General	DRA 18-12	DRA 18-15	DRA 18-24
Switching frequency	approx. 100 kHz		
Insulation voltage input/output	AC 3.0 kV _{eff}		
Insulation voltage input / ground	AC 1.5 kV _{eff}		
Insulation voltage output / ground	–		
Insulation resistance at DC 500 V	100 MΩ		
Operation temperature range	-20 °C – 70 °C (derating)		
Derating	-3% / °C starting at 60 °C		
Storage temperature range	-25 °C – 85 °C		
M.T.B.F.	797000 h	796000 h	800000 h
Relative humidity	20–95 % RH		
Dimensions (w x h x d) in mm	22.5 x 90.0 x 115.0		
Cooling	Air convection		
Housing material	Plastic		
Field installation	rail TS 35 (EN 50022)		
Application height	2000 m		
Installation position	vertical		
Protection class	IP 20		
Overvoltage category	II		
Pollution degree	2		
Protection class	2		
Weight (kg/piece)	0.150		
Termination	Spring terminal: 0.2–2.0 mm ²		
Approvals	UL: UL 508 listed; cUL: UL 60950-1, UL 1310 Class 2; TÜV: EN 60950-1, CE: EN 50081-1 / EN 55022 Class B, EN 61000-3-2, EN 61000-3-3, EN 50082-1 / EN 55024		

Monitoring	DRA 18-12	DRA 18-15	DRA 18-24
DC ON Control (Rdy)	LED green/red		
Switching voltage	–		
Switching current	–		
Switching capacity	–		
Insulation voltage	–		

Power supply - regulated, 30 W

Primary switchmode power supply, Single-phase, Class 2

Input: Wide range input AC 85 V - 264 V; DC 90 V - 375 V

Output: 5 V / 12 V / 24 V / 48 V - adjustable



Dimensions

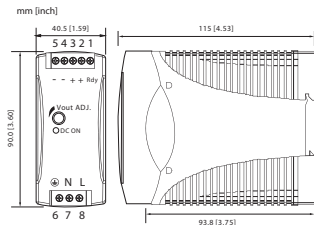

PIN assignment

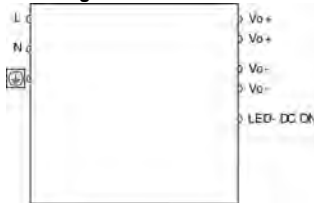

Derating

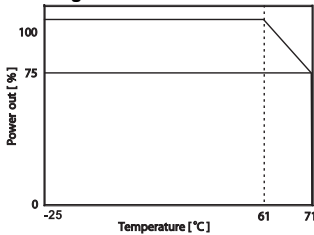

Parallel mode

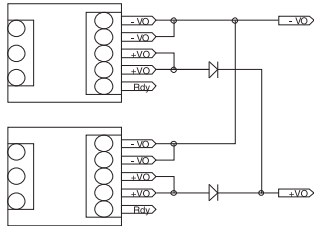

Description	Part-No.	Type	PU	
Screw terminal				
Output voltage/current	DC 5 V; 6 A	722763	DRA 30-05A	1
	DC 12 V; 2.5 A	722768	DRA 30-12A	1
	DC 24 V; 1.25 A	722753	DRA 30-24A	1
	DC 48 V; 0.625 A	722775	DRA 30-48A	1

Input	DRA 30-05A	DRA 30-12A	DRA 30-24A	DRA 30-48A
Nominal voltage	AC 100–240 V			
Operation voltage range	AC 85–264 V / DC 90–375 V			
Line frequency	47 – 63 Hz			
Rated current	U _i = AC 115 V: 360 mA / U _i = AC 230 V: 190 mA			
Inrush current	U _i = AC 115 V: 20 A / U _i = AC 230 V: 40 A			
Internal fuse	T2 A / AC 250 V			
External fuse	Mini-circuit breaker: B 3 A			
Power Factor Correction P.F.C.	-			

Output	DRA 30-05A	DRA 30-12A	DRA 30-24A	DRA 30-48A
Rated voltage output	DC 5 V	DC 12 V	DC 24 V	DC 48 V
Rated current output	6 A	2.5 A	1.25 A	0.625
Max. output current	-			
Peak output current	-			
Voltage trim range	5–5.5 V	12/14 V	24/28 V	48/55 V
Accuracy	±1 %			
Line regulation	±0.5 %			
Load regulation	±0.5 %			
Rise time	1 s			
Temperature coefficient	±0.03 % / °C			
Ripple & Noise	<50 mV			
Hold up time	V _{in} = 115 V: 20 ms / V _{in} = 230 V: 30 ms			
Status indication DC ON LED green	≥4 V	≥9.6 V	≥19.2 V	≥37 V
Status indication DC LOW LED red	-			
Parallel mode	with external diodes			
Efficiency	79 %	84 %	86 %	
Low power loss	8.5 A (AC 230 V)	5.6 A (AC 230 V)	5.5 A (AC 230 V)	4.9 A (AC 230 V)
Rated over load protection	120 – 136 %		110 – 140 %	
Over voltage protection	125–137 %			
Short circuit characteristics	Hiccup-mode			

General				
Switching frequency	approx. 80 kHz			
Insulation voltage input/output	AC 3.0 kV _{eff}			
Insulation voltage input / ground	AC 1.5 kV _{eff}			
Insulation voltage output / ground	-			
Insulation resistance at DC 500 V	100 MΩ			
Operation temperature range	-25 °C – 70 °C (derating)			
Derating	-2.5 % / °C starting at 60 °C			
Storage temperature range	-25 °C – 85 °C			
M.T.B.F.	551000 h	582000 h	588000 h	609000 h
Relative humidity	20–90% RH			
Dimensions (w x h x d) in mm	40.5 x 90.0 x 115.0			
Cooling	Air convection			
Housing material	Plastic			
Field installation	rail TS 35 (EN 50022)			
Application height	2000 m			
Installation position	vertical			
Protection class	IP 20			
Overvoltage category	II			
Pollution degree	2			
Protection class	-		2	
Weight (kg/piece)	0.290			
Termination	Screw terminal: 0.2–2.5 mm ²			

Approvals: UL: UL 508 listed; cUL: UL 60950-1, UL 1310 Class 2; TÜV: EN 60950-1, CE: EN 61000-6-3 / EN 55022 Class B, EN 61000-3-2, EN 601000-3-3, EN 55024, EN 61000-6-2, EN 61000-4-2, EN 61000-4-3, EN 61000-4-4, EN 61000-4-5, EN 61000-4-6, EN 61000-4-8, EN 61000-4-11

Monitoring				
DC ON Control (Rdy)	-	Open Collector		-
Switching voltage	-	DC 24 V		-
Switching current	-	≤ 35 mA		-
Switching capacity	-			
Insulation voltage	-	none		-

Power supply - regulated, 30 W

Primary switchmode power supply, Single-phase, Class 2

Input: Wide range input AC 85 V - 264 V; DC 90 V - 375 V

Output: 5 V / 12 V / 24 V / 48 V - adjustable



Dimensions

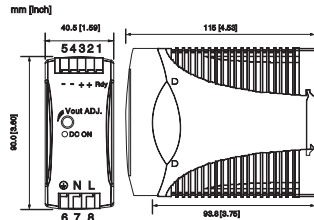

PIN assignment

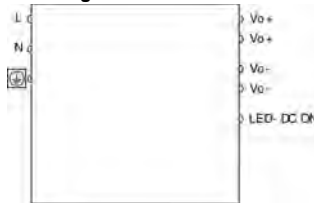

Derating

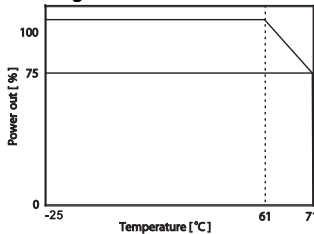

Parallel mode

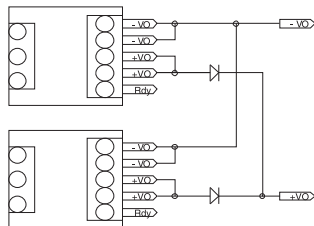

Description	Part-No.	Type	PU	
Spring terminal				
Output voltage/current	DC 5 V; 6 A	728763	DRA 30-05	1
	DC 12 V; 2.5 A	728768	DRA 30-12	1
	DC 24 V; 1.25 A	728753	DRA 30-24	1
	DC 48 V; 0.625 A	728775	DRA 30-48	1

Input	DRA 30-05	DRA 30-12	DRA 30-24	DRA 30-48
Nominal voltage	AC 100–240 V			
Operation voltage range	AC 85–264 V / DC 90–375 V			
Line frequency	47 – 63 Hz			
Rated current	U _i = AC 115 V: 360 mA / U _i = AC 230 V: 190 mA			
Inrush current	U _i = AC 115 V: 20 A / U _i = AC 230 V: 40 A			
Internal fuse	T2 A / AC 250 V			
External fuse	Mini-circuit breaker: B 3 A			
Power Factor Correction P.F.C.	–			
Output				
Rated voltage output	DC 5 V	DC 12 V	DC 24 V	DC 48 V
Rated current output	6 A	2.5 A	1.25 A	0.625
Max. output current	–			
Peak output current	–			
Voltage trim range	5–5.5 V	12/14 V	24/28 V	48/55 V
Accuracy	±1 %			
Line regulation	±0.5 %			
Load regulation	±0.5 %			
Rise time	1 s			
Temperature coefficient	±0.03 % / °C			
Ripple & Noise	<50 mV			
Hold up time	V _{in} = 115 V: 20 ms / V _{in} = 230 V: 30 ms			
Status indication DC ON LED green	≥4 V	≥9.6 V	≥19.2 V	≥37 V
Status indication DC LOW LED red	–			
Parallel mode	with external diodes			
Efficiency	79 %	84 %	86 %	–
Low power loss	8.5 A (AC 230 V)	5.6 A (AC 230 V)	5.5 A (AC 230 V)	4.9 A (AC 230 V)
Rated over load protection	110–140 %			
Over voltage protection	120–136 %			
Short circuit characteristics	Hiccup-mode			
General				
Switching frequency	approx. 80 kHz			
Insulation voltage input/output	AC 3.0 kV _{eff}			
Insulation voltage input / ground	AC 1.5 kV _{eff}			
Insulation voltage output / ground	–			
Insulation resistance at DC 500 V	100 MΩ			
Operation temperature range	-25 °C – 70 °C (derating)			
Derating	-2.5% / °C starting at 60 °C			
Storage temperature range	-25 °C – 85 °C			
M.T.B.F.	551000 h	582000 h	588000 h	609000 h
Relative humidity	20–90% RH			
Dimensions (w x h x d) in mm	40.5 x 90.0 x 115.0			
Cooling	Air convection			
Housing material	Plastic			
Field installation	rail TS 35 (EN 50022)			
Application height	2000 m			
Installation position	vertical			
Protection class	IP 20			
Overvoltage category	II			
Pollution degree	2			
Protection class	–			
Weight (kg/piece)	0.290			
Termination	Spring terminal: 0.2–2.0 mm ²			
Approvals	UL: UL 508 listed; cUL: UL 60950-1; TÜV: EN 60950-1, CE: EN 61000-6-3 / EN 55022 Class B; EN 61000-3-2, EN 601000-3-3; EN 55024; EN 61000-6-2; EN 61000-4-2; EN 61000-4-3, EN 61000-4-4; EN 61000-4-5; EN 61000-4-6; EN 61000-4-8; EN 61000-4-11			
Monitoring				
DC ON Control (Rdy)	–	–	Open Collector	–
Switching voltage	–	–	DC 24 V	–
Switching current	–	–	≤ 35 mA	–
Switching capacity	–	–	–	–
Insulation voltage	–	–	none	–

Power supply - regulated, 30 W

Primary switchmode power supply, PFC, Single-phase, Class 2

Input: Wide range input AC 90 V - 264 V; DC 100 V - 320 V

Output: DC 24 V



Dimensions

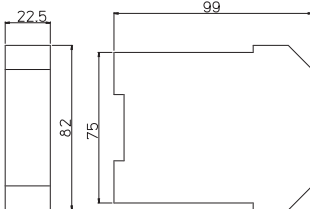

PIN assignment

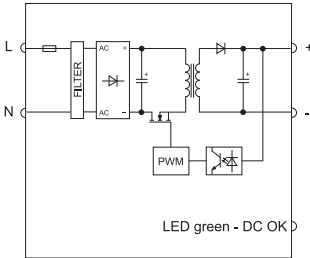

Derating

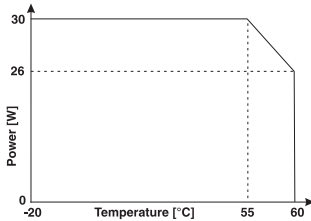

Parallel mode

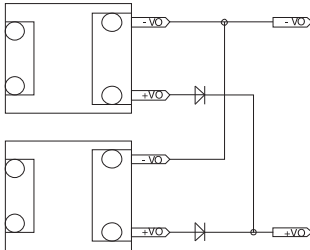

Description	Part-No.	Type	PU
Screw terminal			
Output voltage/current	DC 24 V; 1.2 A	722790	CPSFB1-30-24
			1
Input			
CPSFB1-30-24			
Nominal voltage	AC 120 V / 230 V		
Operation voltage range	AC 90–264 V / DC 100–320 V		
Line frequency	47 – 63 Hz		
Rated current	U _I = AC 120 V: 0.55 A / U _I = AC 240 V: 0.30 A		
Inrush current	<AC 25 A		
Internal fuse	T 1.25 A / AC 250 V		
External fuse	Mini-circuit breaker: C 2 A		
Power Factor Correction P.F.C.	>0.6		
Output			
Rated voltage output	DC 24 V		
Rated current output	1.2 A		
Max. output current	1.4 A (AC 240 V)		
Peak output current	10 A (50 ms)		
Voltage trim range	–		
Accuracy	±1%		
Line regulation	–		
Load regulation	<1 %		
Rise time	–		
Temperature coefficient	–		
Ripple & Noise	<80 mV pp		
Hold up time	>10 ms (AC 120 V); >30 ms (AC 240 V)		
Status indication DC ON LED green	yes		
Status indication DC LOW LED red	No		
Parallel mode	Yes, with external decoupling diode		
Efficiency	>86 % (AC 120 V); > 87 % (AC 240 V)		
Low power loss	<4.7 W (AC 120 V); <4.3 W (AC 240 V)		
Rated over load protection	yes		
Over voltage protection	yes		
Short circuit characteristics	Hiccup-mode		
General			
Switching frequency	–		
Insulation voltage input/output	AC 3.0 kV _{eff}		
Insulation voltage input / ground	class 2, without PE		
Insulation voltage output / ground	class 2, without PE		
Insulation resistance at DC 500 V	– MΩ		
Operation temperature range	-20 °C – 60 °C (derating) (50°C UL508)		
Derating	>55°C: -0.8 W / °C		
Storage temperature range	-25 °C – 85 °C		
M.T.B.F.	–		
Relative humidity	–		
Dimensions (w x h x d) in mm	22.5 x 82.0 x 99.0		
Cooling	Air convection		
Housing material	Noryl UL 94-0		
Field installation	rail TS 35 (EN 50022)		
Application height	– m		
Installation position	vertical		
Protection class	IP 20 (IEC529, EN60529)		
Overvoltage category	II		
Pollution degree	2		
Protection class	–		
Weight (kg/piece)	0.140		
Termination	Screw terminal: 0.2–2.0 mm ²		
Approvals	UL, cUL: UL 508, IEC 950, EN 60950, UL 60950 CE: EN 61000-4-2/3/4/5/6/11, EN 61000-6-2, EN 601000-6-4, EN 50178, EN 61558, EN 61000-3-2, EN 50081-1, EN 50082-2, EN 55022 Class B, EN 55011B		
Monitoring			
DC ON Control (Rdy)	–		
Switching voltage	–		
Switching current	–		
Switching capacity	–		
Insulation voltage	–		

Power supply - regulated, 30;50 W

Primary switchmode power supply, PFC, Single-phase, Class 2
Input: Wide range input AC 90 V - 264 V; DC 110 V - 370 V
Output: DC 24 V



Dimensions

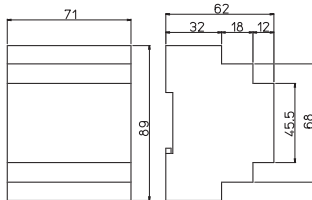

PIN assignment

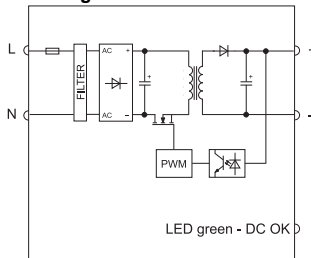

Derating

DC 24 V; 1.2 A

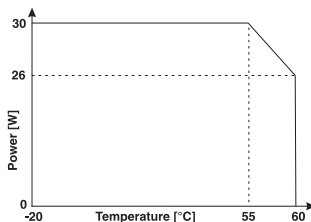

DC 24 V; 2.2 A

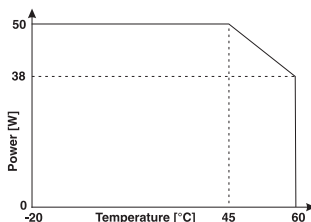

Parallel mode

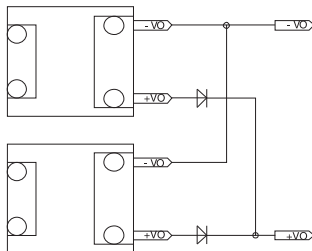

Description	Part-No.	Type	PU	
Screw terminal				
Output voltage/current	DC 24 V; 1.2 A	722787	CPSF1-30-24	1
	DC 24 V; 2.2 A	722788	CPSF1-50-24	1

Input	CPSF1-30-24	CPSF1-50-24
Nominal voltage	AC 115 / 230 V	
Operation voltage range	AC 90–264 V / DC 110–370 V (DC 300 V; UL508)	
Line frequency	47 – 63 Hz	
Rated current	$U_i = AC 100 V: 0.65 A / U_i = AC 240 V: 0.30 A$	$U_i = AC 100 V: 0.90 A / U_i = AC 240 V: 0.50 A$
Inrush current	<AC 13 A	<AC 15 A
Internal fuse	T2 A / AC 250 V	
External fuse	Mini-circuit breaker: B 3 A, C 2 A	
Power Factor Correction P.F.C.	>0.6	

Output		
Rated voltage output	DC 24 V	
Rated current output	1.2 A	2.2 A
Max. output current	2.2 A (AC 240 V)	4 A (AC 240 V)
Peak output current	–	
Voltage trim range	–	
Accuracy	±1%	
Line regulation	–	
Load regulation	<1 %	
Rise time	–	
Temperature coefficient	–	
Ripple & Noise	<50 mV pp	
Hold up time	>20 ms (AC 120 V); >60 ms (AC 240 V)	>20 ms (AC 120 V); >40 ms (AC 240 V)
Status indication DC ON LED green	yes	
Status indication DC LOW LED red	No	
Parallel mode	Yes, with external decoupling diode	
Efficiency	>85 % (AC 120 V); > 87 % (AC 240 V)	>85 % (AC 120 V); > 88 % (AC 240 V)
Low power loss	–	
Rated over load protection	yes	
Over voltage protection	yes	
Short circuit characteristics	Hiccup-mode	

General	
Switching frequency	–
Insulation voltage input/output	AC 3.0 kV _{eff}
Insulation voltage input / ground	class 2, without PE
Insulation voltage output / ground	class 2, without PE
Insulation resistance at DC 500 V	– MΩ
Operation temperature range	-20 °C – 60 °C (derating)
Derating	>55°C: -0.8 W / °C >45°C: -0.8 W / °C
Storage temperature range	-25 °C – 85 °C
M.T.B.F.	–
Relative humidity	–
Dimensions (w x h x d) in mm	71.0 x 89.0 x 62.0
Cooling	Air convection
Housing material	Noryl UL 94-0
Field installation	rail TS 35 (EN 50022)
Application height	– m
Installation position	vertical
Protection class	IP 20 (IEC529, EN60529)
Overvoltage category	II
Pollution degree	2
Protection class	–
Weight (kg/piece)	0.200
Termination	Screw terminal: 0.2–2.5 mm ²
Approvals	UL, cUL: UL 508, IEC 950, EN 60950, UL 60950 CE: EN 61000-4-2/3/4/5/6/11, EN 61000-6-2, EN 601000-6-4, EN 50178, EN 61558, EN 61000-3-2, EN 50081-1, EN 50082-2, EN 55022 Class B, EN 55011B

Monitoring	
DC ON Control (Rdy)	–
Switching voltage	–
Switching current	–
Switching capacity	–
Insulation voltage	–

Power supply - regulated, 50 W

Primary switchmode power supply, Single-phase, Class 2

Input: Wide range input AC 85 V - 264 V; DC 90 V - 375 V

Output: 5 V - adjustable



Dimensions

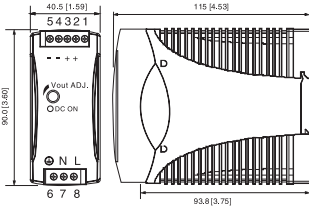

PIN assignment

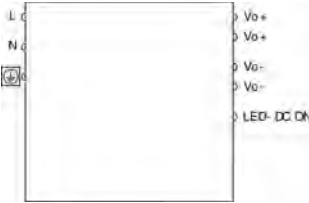

Derating

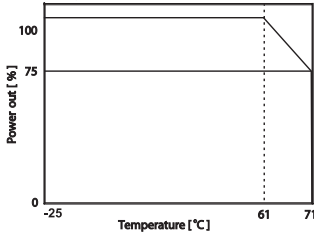

Parallel mode

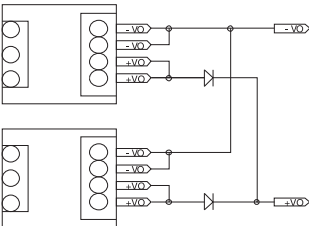

Description	Part-No.	Type	PU	
Screw terminal				
Output voltage/current	DC 5 V; 10 A	722764	DRA 60-05A	1
Spring terminal				
Output voltage/current	DC 5 V; 10 A	728764	DRA 60-05	1
Input				
	DRA 60-05A	DRA 60-05		
Nominal voltage	AC 100–240 V			
Operation voltage range	AC 85–264 V / DC 90–375 V			
Line frequency	47 – 63 Hz			
Rated current	U _i = AC 115 V; AC: 550 mA / U _i = 230 V; AC: 280 mA			
Inrush current	U _i = AC 115 V: 20 A / U _i = AC 230 V: 40 A			
Internal fuse	T2 A / AC 250 V			
External fuse	Mini-circuit breaker: B 3 A, C 2 A			
Power Factor Correction P.F.C.	–			
Output				
Rated voltage output	DC 5 V			
Rated current output	10 A			
Max. output current	–			
Peak output current	–			
Voltage trim range	5.0/5.5 V			
Accuracy	±1 %			
Line regulation	±0.5 %			
Load regulation	±0.5 %			
Rise time	1 s			
Temperature coefficient	±0.03 % / °C			
Ripple & Noise	50 mV			
Hold up time	V _{in} = 115 V: 20 ms / V _{in} = 230 V: 30 ms			
Status indication DC ON LED green	≥4 V			
Status indication DC LOW LED red	–			
Parallel mode	with external diodes			
Efficiency	79 %			
Low power loss	12.5 W			
Rated over load protection	110–150 %			
Over voltage protection	120–136 %			
Short circuit characteristics	Hiccup-mode			
General				
Switching frequency	approx. 80 kHz			
Insulation voltage input/output	AC 3.0 kV _{eff}			
Insulation voltage input / ground	AC 1.5 kV _{eff}			
Insulation voltage output / ground	–			
Insulation resistance at DC 500 V	100 MΩ			
Operation temperature range	-25 °C – 70 °C (derating)			
Derating	-2.5% / °C starting at 60 °C			
Storage temperature range	-25 °C – 85 °C			
M.T.B.F.	498000 h			
Relative humidity	20–90% RH			
Dimensions (w x h x d) in mm	40.5 x 90.0 x 115.0			
Cooling	Air convection			
Housing material	Plastic			
Field installation	rail TS 35 (EN 50022)			
Application height	2000 m			
Installation position	vertical			
Protection class	IP 20			
Overvoltage category	II			
Pollution degree	2			
Protection class	–			
Weight (kg/piece)	0.340			
Termination	Screw terminal 0.2–2.0 mm ²		Spring terminal 0.2–2.0 mm ²	
Approvals	UL: UL 508 listed; cUL: UL 60950-1; TÜV: EN 60950-1, CE: EN 61000-6-3 / EN 55022 Class B; EN 61000-3-2, EN 601000-3-4; EN 55024; EN 61000-6-2; EN 61000-4-2; EN 61000-4-3, EN 61000-4-4; EN 61000-4-5; EN 61000-4-6; EN 61000-4-8; EN 61000-4-11			
Monitoring				
DC ON Control (Rdy)	–			
Switching voltage	–			
Switching current	–			
Switching capacity	–			
Insulation voltage	–			

Power supply - regulated, 60 W

Primary switchmode power supply, Single-phase, Class 2
Input: Wide range input AC 85 V - 264 V; DC 90 V - 375 V
Output: 12 V / 24 V / 48 V - adjustable



Dimensions

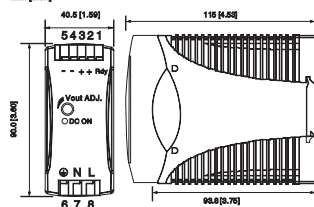

PIN assignment



Derating

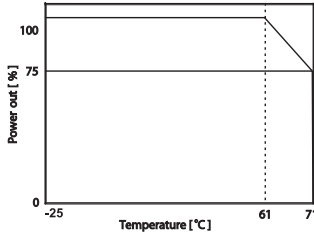

Parallel mode

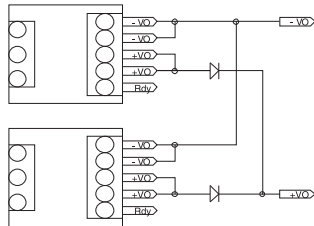

Description	Part-No.	Type	PU	
Spring terminal				
Output voltage/current	DC 12 V; 5 A	728769	DRA 60-12	1
	DC 24 V; 2.5 A	728754	DRA 60-24	1
	DC 48 V; 1.25 A	728776	DRA 60-48	1
Input				
	DRA 60-12	DRA 60-24	DRA 60-48	
Nominal voltage	AC 100–240 V			
Operation voltage range	AC 85–264 V / DC 90–375 V			
Line frequency	47 – 63 Hz			
Rated current	U _I = AC 115 V: 690 mA / U _I = AC 230 V: 360 mA			
Inrush current	U _I = AC 115 V: 20 A / U _I = AC 230 V: 40 A			
Internal fuse	T2 A / AC 250 V			
External fuse	Mini-circuit breaker: B 5 A			
Power Factor Correction P.F.C.	–			
Output				
Rated voltage output	DC 12 V	DC 24 V	DC 48 V	
Rated current output	5 A	2.5 A	1.25 A	
Max. output current	–			
Peak output current	–			
Voltage trim range	12/14 V	24/28 V	48/55 V	
Accuracy	±1 %			
Line regulation	±0.5 %			
Load regulation	±0.5 %			
Rise time	1 s			
Temperature coefficient	±0.03 % / °C			
Ripple & Noise	50 mV			
Hold up time	V _{in} = 115 V: 20 ms / V _{in} = 230 V: 30 ms			
Status indication DC ON LED green	≥9.6 V	≥19.2 V	≥37 V	
Status indication DC LOW LED red	–			
Parallel mode	with external diodes			
Efficiency	86 %	89 %	89 %	
Low power loss	9.0 W	8.8 W	7.8 W	
Rated over load protection	110–150 %			
Over voltage protection	125–138 %			
Short circuit characteristics	Hiccup-mode			
General				
Switching frequency	approx. 80 kHz			
Insulation voltage input/output	AC 3.0 kV _{eff}			
Insulation voltage input / ground	AC 1.5 kV _{eff}			
Insulation voltage output / ground	–			
Insulation resistance at DC 500 V	100 MΩ			
Operation temperature range	-25 °C – 70 °C (derating)			
Derating	-2.5% / °C starting at 60 °C			
Storage temperature range	-25 °C – 85 °C			
M.T.B.F.	504000 h	520000 h	531000 h	
Relative humidity	20–90% RH			
Dimensions (w x h x d) in mm	40.5 x 90.0 x 115.0			
Cooling	Air convection			
Housing material	Plastic			
Field installation	rail TS 35 (EN 50022)			
Application height	2000 m			
Installation position	vertical			
Protection class	IP 20			
Overvoltage category	II			
Pollution degree	2			
Protection class	–	2	2	
Weight (kg/piece)	0.340			
Termination	Spring terminal 0.2–2.0 mm ²			
Approvals	UL: UL 508 listed; cUL: UL 60950-1, UL 1310 Class 2 (nicht 12 V) Recognized; TÜV: EN 60950-1, EN 61558-1, EN 61558-2-17 CE: EN 61000-6-3 / EN 55022 Class B; EN 61000-3-2 EN 61000-3-3; EN 55024; EN 61000-6-2; EN 61000-4-2; EN 61000-4-3 EN 61000-4-4; EN 61000-4-5; EN 61000-4-6; EN 61000-4-8; EN 61000-4-11			
Monitoring				
DC ON Control (Rdy)	–	Open Collector	–	
Switching voltage	–	DC 24 V	–	
Switching current	–	≤ 35 mA	–	
Switching capacity	–	–	–	
Insulation voltage	–	none	–	

Power supply - regulated, 70 W

Primary switchmode power supply, PFC, Single-phase, Class 2

Input: Wide range input AC 90 V - 264 V; DC 100 V - 350 V

Output: DC 24 V - adjustable



Dimensions

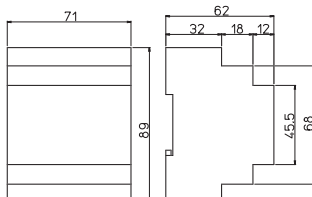

PIN assignment

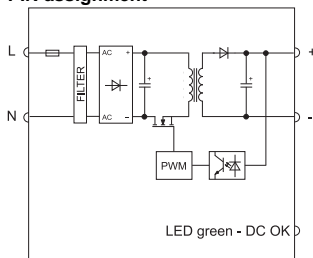

Derating

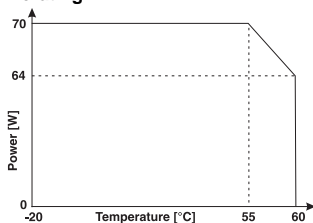

Parallel mode

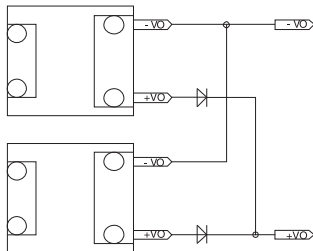

Description	Part-No.	Type	PU
Screw terminal			
Output voltage/current	DC 24 V; 3 A	722789	CPSF1-70-24
			1
Input			
CPSF1-70-24			
Nominal voltage	AC 115 / 230 V		
Operation voltage range	AC 90–264 V / DC 100–350 V (DC 300 V; UL508)		
Line frequency	47 – 63 Hz		
Rated current	U _I = AC 100 V: 1.25 A / U _I = AC 240 V: 0.80 A		
Inrush current	<AC 30 A		
Internal fuse	T2 A / AC 250 V		
External fuse	Mini-circuit breaker: B 5 A, C 4 A		
Power Factor Correction P.F.C.	>0.6		
Output			
Rated voltage output	DC 24 V		
Rated current output	3 A		
Max. output current	4 A (AC 240 V)		
Peak output current	–		
Voltage trim range	23,5–27,5 V		
Accuracy	–		
Line regulation	–		
Load regulation	<1 %		
Rise time	–		
Temperature coefficient	–		
Ripple & Noise	<60 mV pp		
Hold up time	>10 ms (AC 120 V); >30 ms (AC 240 V)		
Status indication DC ON LED green	yes		
Status indication DC LOW LED red	No		
Parallel mode	Yes, with external decoupling diode		
Efficiency	>87 % (AC 120 V); > 89 % (AC 240 V)		
Low power loss	–		
Rated over load protection	yes		
Over voltage protection	yes		
Short circuit characteristics	Hiccup-mode		
General			
Switching frequency	–		
Insulation voltage input/output	AC 3.0 kV _{eff}		
Insulation voltage input / ground	class 2, without PE		
Insulation voltage output / ground	class 2, without PE		
Insulation resistance at DC 500 V	– MΩ		
Operation temperature range	-20 °C – 60 °C (derating) (55°C UL508)		
Derating	>55°C: -1.2 W / °C		
Storage temperature range	-25 °C – 85 °C		
M.T.B.F.	–		
Relative humidity	–		
Dimensions (w x h x d) in mm	71.0 x 89.0 x 62.0		
Cooling	Air convection		
Housing material	Noryl UL 94-0		
Field installation	rail TS 35 (EN 50022)		
Application height	– m		
Installation position	vertical		
Protection class	IP 20 (IEC529, EN60529)		
Overvoltage category	II		
Pollution degree	2		
Protection class	–		
Weight (kg/piece)	0.250		
Termination	Screw terminal: 0.2–2.5 mm ²		
Approvals	UL, cUL: UL 508, IEC 950, EN 60950, UL 60950 CE: EN 61000-4-2/3/4/5/6/11, EN 61000-6-2, EN 601000-6-4, EN 50178, EN 61558, EN 61000-3-2, EN 50081-1, EN 50082-2, EN 55022 Class B, EN 55011B		
Monitoring			
DC ON Control (Rdy)	–		
Switching voltage	–		
Switching current	–		
Switching capacity	–		
Insulation voltage	–		

Power supply - regulated, 93 W, Class 2 compliant

Primary switchmode power supply, PFC, Single-phase, screw terminal - pluggable
 Input: Wide range input AC 90 V - 132 V; AC 186 - 264 V, DC 210 V - 370 V
 Output: 24 V - adjustable

GB / USA



Dimensions

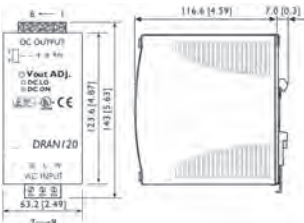

PIN assignment

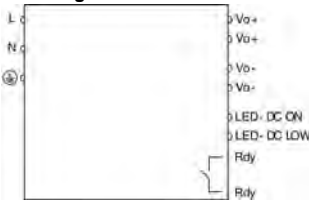

Derating

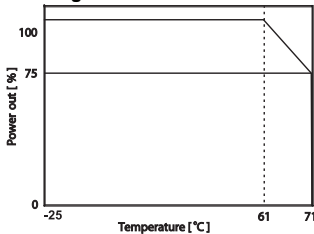

Parallel mode

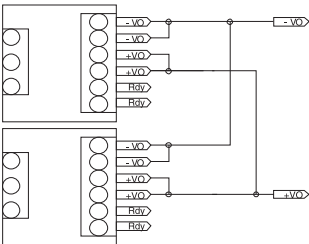

Description	Part-No.	Type	PU
Screw terminal, pluggable			
Output voltage/current	DC 24 V; 3.8 A	722757	DRAN 120-24AL
			1
Input			
DRAN 120-24AL			
Nominal voltage	AC 115 / 230 V (auto select)		
Operation voltage range	AC 90–132 V; AC 186–264 V / DC 210–370 V		
Line frequency	47 – 63 Hz		
Rated current	U _I = AC 115 V: 1.1 A / U _I = AC 230 V: 0.55 A		
Inrush current	U _I = AC 115 V: 24 A / U _I = AC 230 V 48 A		
Internal fuse	T3, 15 A / AC 250 V		
External fuse	Mini-circuit breaker: B 5 A		
Power Factor Correction P.F.C.	0.7		
Output			
Rated voltage output	DC 24 V		
Rated current output	3.8 A		
Max. output current	–		
Peak output current	–		
Voltage trim range	22.5–28.5 V		
Accuracy	±1 %		
Line regulation	±0.5 %		
Load regulation	Single ±1 %, Parallel ±5 %		
Rise time	1 s		
Temperature coefficient	±0.03 % / °C		
Ripple & Noise	50 mV		
Hold up time	V _{in} = 115 V: 25 ms / V _{in} = 230 V: 30 ms		
Status indication DC ON LED green	≥17.6–19.4 V		
Status indication DC LOW LED red	≤17.6–19.4 V		
Parallel mode	max. 3 units at 90% load current		
Efficiency	86 %		
Low power loss	16 W		
Rated over load protection	105–125 %		
Over voltage protection	125–145 %		
Short circuit characteristics	Current limit		
General			
Switching frequency	approx. 80 kHz		
Insulation voltage input/output	AC 3.0 kV _{eff}		
Insulation voltage input / ground	AC 1.5 kV _{eff}		
Insulation voltage output / ground	–		
Insulation resistance at DC 500 V	100 MΩ		
Operation temperature range	-25 °C – 70 °C (derating)		
Derating	-2.5% / °C starting at 60 °C		
Storage temperature range	-25 °C – 85 °C		
M.T.B.F.	486000 h		
Relative humidity	20–90% RH		
Dimensions (w x h x d) in mm	63.5 x 142.0 x 116.0		
Cooling	Air convection		
Housing material	metal		
Field installation	rail TS 35 (EN 50022)		
Application height	– m		
Installation position	vertical		
Protection class	IP 20		
Overvoltage category	II		
Pollution degree	2		
Protection class	2		
Weight (kg/piece)	0.920		
Termination	Screw terminal: 0.2–2.0 mm ²		
Approvals	UL: UL 508 listed, cUL: UL 60950-1, TÜV: EN 60950, EN 55022 Class B, EN 55024 Class 2, EN 61000-3-2, EN 61000-3-3, EN 61000-6-2, EN 61000-6-3		
Monitoring			
DC ON Control (Rdy)	Normally open		
Switching voltage	DC 60 V		
Switching current	max. 300 mA		
Switching capacity	–		
Insulation voltage	DC 500 V		

Power supply - regulated, 120 W

Primary switchmode power supply, PFC, Single-phase, screw terminal - pluggable
 Input: Wide range input AC 90–132 V; AC 186–264 V, DC 210–370 V
 Output: 12 V / 24 V / 48 V - adjustable



Dimensions

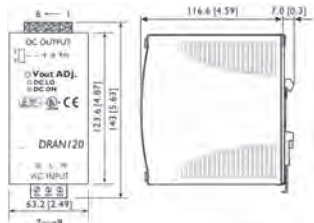

PIN assignment

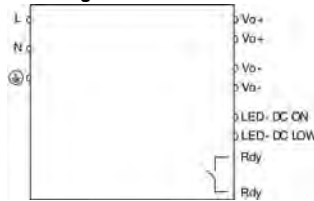

Derating

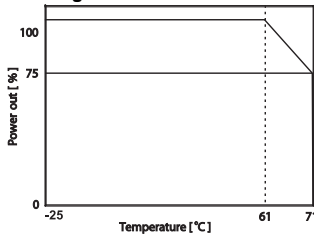

Parallel mode

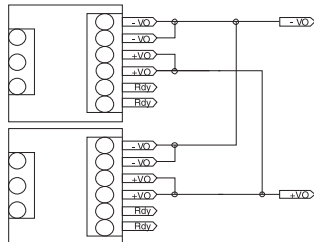

Description	Part-No.	Type	PU	
Screw terminal, pluggable				
Output voltage/current	DC 12 V; 10 A	722770	DRAN 120-12B	1
	DC 24 V; 5 A	722758	DRAN 120-24B	1
	DC 48 V; 2.5 A	722777	DRAN 120-48B	1
Input				
	DRAN 120-12B	DRAN 120-24B	DRAN 120-48B	
Nominal voltage	AC 115 / 230 V (auto select)			
Operation voltage range	AC 90–132 V; AC 186–264 V / DC 210–370 V			
Line frequency	47 – 63 Hz			
Rated current	U _I = AC 115 V: 1.25 A / U _I = AC 230 V: 0.63 A			
Inrush current	U _I = AC 115 V: 24 A / U _I = AC 230 V: 48 A			
Internal fuse	T3, 15 A / AC 250 V			
External fuse	Mini-circuit breaker: B 5 A			
Power Factor Correction P.F.C.	0.7			
Output				
Rated voltage output	DC 12 V	DC 24 V	DC 48 V	
Rated current output	10 A	5 A	2.5 A	
Max. output current	–			
Peak output current	–			
Voltage trim range	11.4–14.5 V	22.5–28.5 V	45/55 V	
Accuracy	±1 %			
Line regulation	±0.5 %			
Load regulation	Single ±1 %, Parallel ±5 %			
Rise time	1 s			
Temperature coefficient	±0.03 % / °C			
Ripple & Noise	50 mV			
Hold up time	V _{in} = 115 V: 25 ms / V _{in} = 230 V: 30 ms			
Status indication DC ON LED green	≥10–11.2 V	≥17.6–19.4 V	≥37–43 V	
Status indication DC LOW LED red	≤10–11.2 V	≤17.6–19.4 V	≤37–43 V	
Parallel mode	max. 3 units at 90% load current, manual switch			
Efficiency	84 %	86 %	87 %	
Low power loss	24 W	20 W	19 W	
Rated over load protection	105–125 %			
Over voltage protection	125–145 %			
Short circuit characteristics	Current limit			
General				
Switching frequency	approx. 80 kHz			
Insulation voltage input/output	AC 3.0 kV _{eff}			
Insulation voltage input / ground	AC 1.5 kV _{eff}			
Insulation voltage output / ground	–			
Insulation resistance at DC 500 V	100 MΩ			
Operation temperature range	-25 °C – 70 °C (derating)			
Derating	-2.5% / °C starting at 60 °C			
Storage temperature range	-25 °C – 85 °C			
M.T.B.F.	440000 h	450000 h	482000 h	
Relative humidity	20–90% RH			
Dimensions (w x h x d) in mm	63.5 x 142.0 x 116.0			
Cooling	Air convection			
Housing material	metal			
Field installation	rail TS 35 (EN 50022)			
Application height	– m			
Installation position	vertical			
Protection class	IP 20			
Overvoltage category	II			
Pollution degree	2			
Protection class	–			
Weight (kg/piece)	0.920			
Termination	Screw terminal: 0.2–2.0 mm ²			
Approvals	UL: UL 508 listed; cUL: UL 60950-1; TÜV: EN 60950, CE: EN 61000-6-3, EN 55022 Class B, EN 61000-3-2, EN 61000-3-3, EN 61000-6-2, EN 55024			
Monitoring				
DC ON Control (Rdy)	–	Normally open	–	
Switching voltage	–	DC 60 V	–	
Switching current	–	max. 300 mA	–	
Switching capacity	–	–	–	
Insulation voltage	–	DC 500 V	–	

Power supply - regulated, 120 W

Primary switchmode power supply, PFC, Single-phase
Input: Wide range input AC 90 V - 264 V; DC 120 V - 370 V
Output: 24 V - adjustable



Dimensions

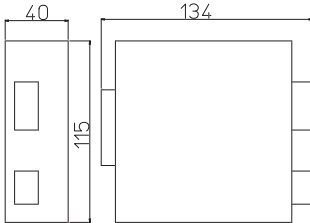

PIN assignment

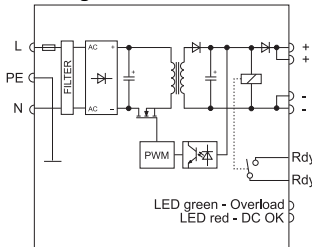

Derating

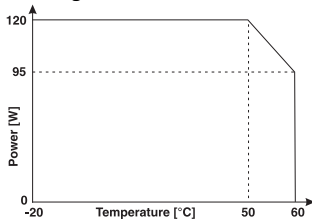

Parallel mode

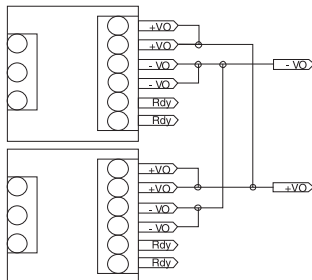

Description	Part-No.	Type	PU	
Screw terminal				
Output voltage/current	DC 24 V; 5 A	722783	CPSB1-120-24R	1
	DC 48 V; 2.5 A	722784	CPSB1-120-48R	1

Input	CPSB1-120-24R	CPSB1-120-48R
Nominal voltage	AC 120 V / 230 V	
Operation voltage range	AC 90–264 V / DC 110–370 V	
Line frequency	47 – 63 Hz	
Rated current	U _i = AC 115 V: 1.9 A / U _i = AC 230 V: 1.1 A	
Inrush current	<AC 20 A	
Internal fuse	T3, 15 A / AC 250 V	
External fuse	Mini-circuit breaker: B 5 A, C 4 A	
Power Factor Correction P.F.C.	>0.6	

Output	CPSB1-120-24R	CPSB1-120-48R
Rated voltage output	DC 24 V	DC 48 V
Rated current output	5 A	2.5 A
Max. output current	8 A (30 s)	4 A (30 s)
Peak output current	–	
Voltage trim range	DC 23–27.5 V	DC 45–55 V
Accuracy	–	
Line regulation	–	
Load regulation	<1 %	
Rise time	–	
Temperature coefficient	–	

Ripple & Noise	30 mV	
Hold up time	>17 ms (AC 120 V); >72 ms (AC 230 V)	
Status indication DC ON LED green	≥21.6 V	≥43.2 V
Status indication DC LOW LED red	≤21.6 V	≤43.2 V
Parallel mode	Yes, decoupling diode contained internally	
Efficiency	>90 % (AC 230 V); > 86 % (AC 120 V)	
Low power loss	19 W (AC 120 V); 13 W (AC 230 V)	20 W (AC 120 V); 13 W (AC 230 V)
Rated over load protection	yes	
Over voltage protection	yes	
Short circuit characteristics	Hiccup-mode	

General		
Switching frequency	–	
Insulation voltage input/output	AC 3.0 kV _{eff}	
Insulation voltage input / ground	AC 1.5 kV _{eff}	
Insulation voltage output / ground	AC 0.5 kV _{eff}	
Insulation resistance at DC 500 V	– MΩ	
Operation temperature range	-20 °C – 60 °C (derating)	
Derating	>50°C: -2.5 W / °C	
Storage temperature range	-25 °C – 85 °C	
M.T.B.F.	>500000 h to SN29500 / >150000 h to MIL standard HDBK 217F	
Relative humidity	–	

Dimensions (w x h x d) in mm	40.0 x 115.0 x 128.0	
Cooling	Air convection	
Housing material	Aluminium	
Field installation	rail TS 35 (EN 50022)	
Application height	– m	
Installation position	vertical	
Protection class	IP 20 (IEC529, EN60529)	
Overvoltage category	II	
Pollution degree	2	
Protection class	–	
Weight (kg/piece)	0.400	

Termination	Screw terminal: 0.2–2.5 mm ² - pluggable	
Approvals	UL, cUL: UL 508, IEC 950, EN 60950, UL 60950 CE: EN 61000-4-2/3/4/5/6/11, EN 61000-6-2, EN 601000-6-4, EN 50178, EN 61558, EN 50081-1, EN 50082-2, EN 55022 Class B	

Monitoring		
DC ON Control (Rdy)	Normally open	
Switching voltage	AC 300 V / DC 150 V	
Switching current	AC/DC 1 A	
Switching capacity	300 VA / 30 W	
Insulation voltage	AC 500 V	

Power supply - regulated, 120 Watts, IP 65

Primary switchmode power supply, PFC, Single-phase
Input: Wide range input AC 90 V - 264 V; DC 110 V - 300 V
Output: DC 24 V - adjustable



Dimensions

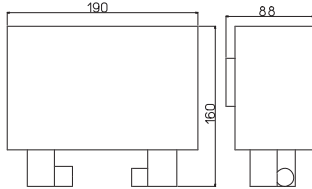

PIN assignment

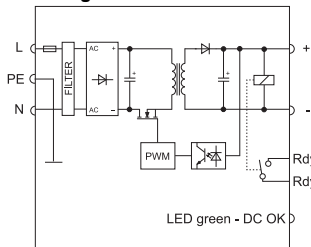

Parallel mode

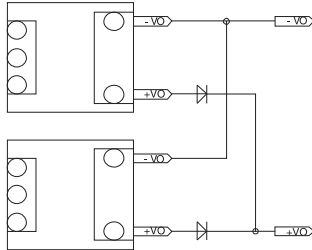

Description	Part-No.	Type	PU
Screw terminal, pluggable			
Output voltage/current	DC 24 V; 5 A	722794	CPS65-120-24
			1
Input			
CPS65-120-24			
Nominal voltage	AC 120 V / 230 V		
Operation voltage range	AC 90–264 V / DC 110–300 V		
Line frequency	47 – 63 Hz		
Rated current	U _I = AC 120 V: 1.8 A / U _I = AC 240 V: 1.0 A		
Inrush current	<AC 20 A		
Internal fuse	T3, 15 A / AC 250 V		
External fuse	Mini-circuit breaker: B 5 A, C 4 A		
Power Factor Correction P.F.C.	>0.7		
Output			
Rated voltage output	DC 24 V		
Rated current output	5 A		
Max. output current	8 A (AC 120 V); 10 A (AC 240 V)		
Peak output current	–		
Voltage trim range	DC 23–27.5 V		
Accuracy	–		
Line regulation	–		
Load regulation	<1 %		
Rise time	–		
Temperature coefficient	–		
Ripple & Noise	<80 mV (AC 120 V); < 50 mV (AC 240 V)		
Hold up time	>20 ms (AC 240 V)		
Status indication DC ON LED green	yes		
Status indication DC LOW LED red	No		
Parallel mode	Yes, with external decoupling diode		
Efficiency	>86 % (AC 120 V); > 90 % (AC 240 V)		
Low power loss	18.6 W (AC 120 V); 12.6 W (AC 240 V)		
Rated over load protection	yes		
Over voltage protection	yes		
Short circuit characteristics	Hiccup-mode		
General			
Switching frequency	–		
Insulation voltage input/output	AC 3.0 kV _{eff}		
Insulation voltage input / ground	AC 1.5 kV _{eff}		
Insulation voltage output / ground	AC 0.5 kV _{eff}		
Insulation resistance at DC 500 V	– MΩ		
Operation temperature range	-20 °C – 60 °C		
Derating	–		
Storage temperature range	-25 °C – 85 °C		
M.T.B.F.	–		
Relative humidity	–		
Dimensions (w x h x d) in mm	190.0 x 80.0 x 120.0		
Cooling	Air convection		
Housing material	Noryl UL 94-0		
Field installation	rail TS 35 (EN 50022)		
Application height	– m		
Installation position	vertical		
Protection class	IP 65 (IEC529, EN60529)		
Overvoltage category	II		
Pollution degree	2		
Protection class	–		
Weight (kg/piece)	1.300		
Termination	Screw terminal: 0.2–2.5 mm ² - pluggable		
Approvals	UL, cUL: UL 508, IEC 950, EN 60950 CE: EN 61000-4-2/3/4/5/6/11, EN 61000-6-2, EN 601000-6-4, EN 50178, EN 61558, EN 50081-1, EN 50082-2, EN 61000-3-2		
Monitoring			
DC ON Control (Rdy)	Normally open		
Switching voltage	AC 300 V / DC 150 V		
Switching current	AC/DC 1 A		
Switching capacity	300 VA / 30 W		
Insulation voltage	AC 500 V		

Power supply - regulated, 120 W

Primary switchmode power supply, PFC, 1- / 2-phase

Input: Wide range input AC 187 V - 550 V; DC 270 V - 725 V

Output: 24 V - adjustable



Dimensions

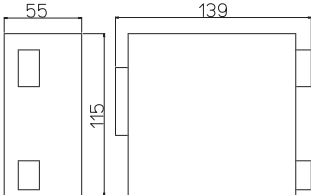

PIN assignment

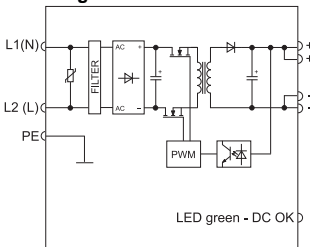

Derating

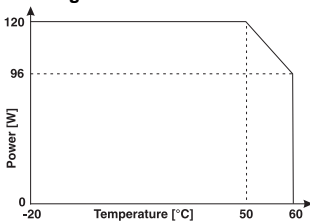

Parallel mode

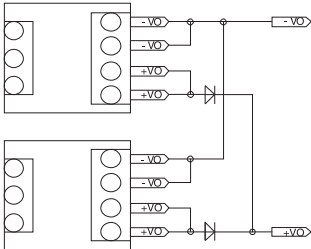

Description	Part-No.	Type	PU
Screw terminal, pluggable			
Output voltage/current	DC 24 V; 5 A	722983	CPSB2-120-24
			1
Input		CPSB2-120-24	
Nominal voltage	AC 200–500 V		
Operation voltage range	AC 187–550 V / DC 270–725 V		
Line frequency	47 – 63 Hz		
Rated current	U _i = AC 200 V: 1.2 A / U _i = AC 500 V: 0.5 A		
Inrush current	<AC 20 A (AC 200 V); <AC 45 A (AC 500 V)		
Internal fuse	–		
External fuse	Mini-circuit breaker: B 10 A, C 6 A		
Power Factor Correction P.F.C.	>0.7		
Output			
Rated voltage output	DC 24 V		
Rated current output	5 A		
Max. output current	5.5 A (AC 240 V)		
Peak output current	22 A (AC 200 V); 32 A (AC 500 V) 0.50 sec.		
Voltage trim range	23/27.5 V		
Accuracy	–		
Line regulation	–		
Load regulation	<1 %		
Rise time	–		
Temperature coefficient	–		
Ripple & Noise	50 mV pp		
Hold up time	>20 ms (AC 200 V); >200 ms (AC 500 V)		
Status indication DC ON LED green	≥21.6 V		
Status indication DC LOW LED red	≤21.6 V		
Parallel mode	Yes, with external decoupling diode		
Efficiency	>86 %		
Low power loss	<22 W max.		
Rated over load protection	yes		
Over voltage protection	yes		
Short circuit characteristics	Hiccup-mode		
General			
Switching frequency	–		
Insulation voltage input/output	AC 3.0 kV _{eff}		
Insulation voltage input / ground	AC 2.0 kV _{eff}		
Insulation voltage output / ground	AC 0.5 kV _{eff}		
Insulation resistance at DC 500 V	– MΩ		
Operation temperature range	-20 °C – 60 °C (derating)		
Derating	>50°C: -2.4 W / °C		
Storage temperature range	-25 °C – 85 °C		
M.T.B.F.	–		
Relative humidity	–		
Dimensions (w x h x d) in mm	55.0 x 115.0 x 130.0		
Cooling	Air convection		
Housing material	Aluminium		
Field installation	rail TS 35 (EN 50022)		
Application height	– m		
Installation position	vertical		
Protection class	IP 20 (IEC529, EN60529)		
Overvoltage category	II		
Pollution degree	2		
Protection class	–		
Weight (kg/piece)	0.600		
Termination	Screw terminal: 0.2–2.5 mm ² - pluggable		
Approvals	UL, cUL: UL 508, IEC 950, EN 60950 CE: EN 61000-4-2/3/4/5/6/11, EN 61000-6-2, EN 601000-6-4, EN 50178, EN 61558, EN 50081-1, EN 50082-2, EN 55022 Class B		
Monitoring			
DC ON Control (Rdy)	Normally open		
Switching voltage	AC 300 V / DC 150 V		
Switching current	AC/DC 1 A		
Switching capacity	300 VA / 30 W		
Insulation voltage	AC 500 V		

Power supply - regulated, 120 W, 3-phase

Primary switchmode power supply, PFC, 3-phase

Input: Wide range input AC 340 V - 576 V; DC 480 V - 820 V

Output: 24 V - adjustable



Dimensions

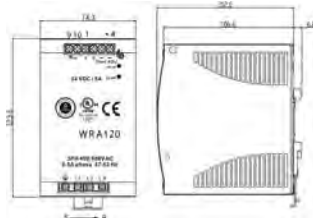

PIN assignment

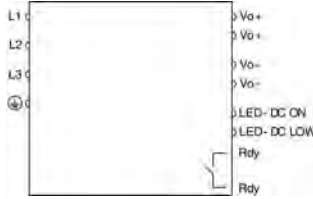

Derating

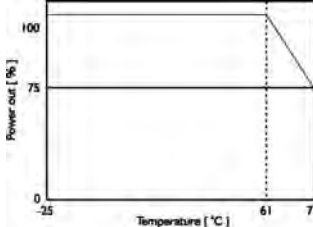

Parallel mode

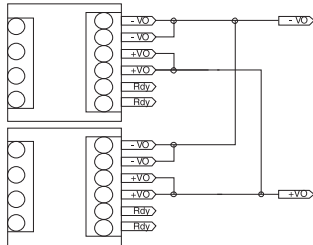

Description	Part-No.	Type	PU
Screw terminal			
Output voltage/current	DC 24 V; 5 A	722803	WRA 120-24
			1
Input			
WRA 120-24			
Nominal voltage	3x AC 380–480 V		
Operation voltage range	3x AC 340–575 V; 3x DC 480–820 V		
Line frequency	47 – 63 Hz		
Rated current	U _I = AC 380 V: 0.5 A / U _I = AC 500 V: 0.35 A		
Inrush current	10 A		
Internal fuse	3xT2, 0 A / AC 600 V		
External fuse	Mini-circuit breaker: 3x B 3 A		
Power Factor Correction P.F.C.	0.6		
Output			
Rated voltage output	DC 24 V		
Rated current output	5 A		
Max. output current	–		
Peak output current	–		
Voltage trim range	22.5/28.5 V		
Accuracy	1 %		
Line regulation	±1 %		
Load regulation	±1 %		
Rise time	1 s		
Temperature coefficient	±0.03 % / °C		
Ripple & Noise	100 mV		
Hold up time	min. 20 ms		
Status indication DC ON LED green	≥17.6–19.4 V		
Status indication DC LOW LED red	≤17.6–19.4 V		
Parallel mode	No		
Efficiency	89 %		
Low power loss	16 W		
Rated over load protection	115 - 135 %, temperature: disconnection at 100–110°C and automatic activation when cool off		
Over voltage protection	125–137 %		
Short circuit characteristics	Hiccup-mode		
General			
Switching frequency	approx. 70 kHz		
Insulation voltage input/output	AC 3.0 kV _{eff}		
Insulation voltage input / ground	AC 1.5 kV _{eff}		
Insulation voltage output / ground	–		
Insulation resistance at DC 500 V	100 MΩ		
Operation temperature range	-25 °C – 71 °C (derating)		
Derating	Capacity: -2.5% / °C starting at +61 °C		
Storage temperature range	-25 °C – 85 °C		
M.T.B.F.	559000 h		
Relative humidity	20–95% RH		
Dimensions (w x h x d) in mm	74.3 x 123.6 x 118.8		
Cooling	Air convection		
Housing material	Metal		
Field installation	rail TS 35 (EN 50022)		
Application height	3000 m		
Installation position	vertical		
Protection class	IP 20		
Overvoltage category	II		
Pollution degree	2		
Protection class	–		
Weight (kg/piece)	0.800		
Termination	Screw terminal: 0.2–5.0 mm ²		
Approvals	UL: UL 508 listed, cUL: UL 60950-1 accepted, TÜV: EN 60950-1; CE: EN 61000-6-3 / EN 55022 Class B, EN 61000-3-2, EN 61000-3-3, EN 61000-6-2, EN 55024		
Monitoring			
DC ON Control (Rdy)	Normally open		
Switching voltage	DC 60 V		
Switching current	max. 300 mA		
Switching capacity	–		
Insulation voltage	DC 500 V		

Power supply - regulated, 240 W

Primary switchmode power supply, PFC, Single-phase

Input: Wide range input AC 93 - 132 V; AC 186 - 264 V, DC 210 - 370 V

Output: 24 V / 48 V - adjustable



Dimensions

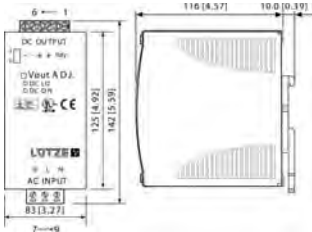

PIN assignment

DC 24 V; 10 A

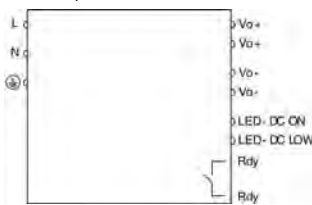

DC 48 V; 5 A, DC 24 V; 10 A

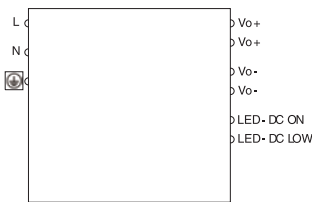

Derating

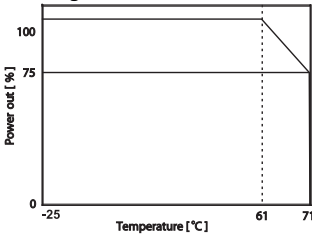

Parallel mode

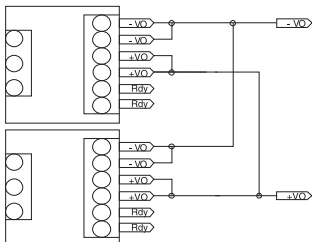

Description	Part-No.	Type	PU	
Screw terminal, pluggable				
Output voltage/current	DC 24 V; 10 A	722759	DRA 240-24B	1
	DC 48 V; 5 A	722778	DRA 240-48B	1
Screw terminal				
Output voltage/current	DC 24 V; 10 A	722781	DRA 240-24A	1
Input				
	DRA 240-24B	DRA 240-48B	DRA 240-24A	
Nominal voltage	AC 115 / 230 V (auto select)			
Operation voltage range	AC 93–132 V; AC 186–264 V / DC 210–370 V			
Line frequency	47 – 63 Hz			
Rated current	U _i = AC 115 V: 2.4 A / U _i = AC 230 V: 1.2 A			
Inrush current	U _i = AC 115 V: 30 A / U _i = AC 230 V: 60 A			
Internal fuse	T6, 3 A / AC 250 V			
External fuse	Mini-circuit breaker: B 10 A, C 6 A			
Power Factor Correction P.F.C.	0.7			
Output				
Rated voltage output	DC 24 V	DC 48 V	DC 24 V	
Rated current output	10 A	5 A	10 A	
Max. output current	–			
Peak output current	–			
Voltage trim range	22.5–28.5	47/56 V	22.5–28.5 V	
Accuracy	±1 %			
Line regulation	±0.5 %			
Load regulation	Single ±1 %, Parallel ±5 %			
Rise time	1 s			
Temperature coefficient	±0.03 % / °C			
Ripple & Noise	100 mV			
Hold up time	V _{in} = 115 V: 25 ms / V _{in} = 230 V: 30 ms			
Status indication DC ON LED green	≥17.6–19.4 V	≥37–43 V	≥17.6–19.4 V	
Status indication DC LOW LED red	≤17.6–19.4 V	≤37–43 V	≤17.6–19.4 V	
Parallel mode	max. 3 units at 90% load current, manual switch			
Efficiency	89 %	90 %	89 %	
Low power loss	–			
Rdy	–			
Rated over load protection	105–145 %			
Over voltage protection	120–145 %			
Short circuit characteristics	Current limit			
General				
Switching frequency	approx. 40 kHz			
Insulation voltage input/output	AC 3.0 kV _{eff}			
Insulation voltage input / ground	AC 1.5 kV _{eff}			
Insulation voltage output / ground	–			
Insulation resistance at DC 500 V	100 MΩ			
Operation temperature range	-25 °C – 70 °C (derating)			
Derating	-2.5% / °C starting at 60 °C			
Storage temperature range	-25 °C – 85 °C			
M.T.B.F.	423000 h	437000 h	423000 h	
Relative humidity	20–95% RH			
Dimensions (w x h x d) in mm	83.0 x 142.0 x 116.0			
Cooling	Air convection			
Housing material	metal			
Field installation	rail TS 35 (EN 50022)			
Application height	2000 m			
Installation position	vertical			
Protection class	IP 20			
Overvoltage category	II			
Pollution degree	2			
Protection class	–			
Weight (kg/piece)	1.000			
Termination	Screw terminal: 0.5–4.0 mm ² , pluggable		Screw terminal: 0.2–2.0 mm ²	
Approvals	UL: UL 508 listed; cUL: UL 60950-1; TÜV: EN 60950, CE: EN 61000-6-3, EN 55022 Class B, EN 61000-3-2, EN 61000-3-3, EN 61000-6-2, EN 55024			
Monitoring				
DC ON Control (Rdy)	Normally open	–	Normally open	
Switching voltage	DC 60 V	–	DC 60 V	
Switching current	max. 300 mA	–	max. 300 mA	
Switching capacity	–	–	–	
Insulation voltage	DC 500 V	–	DC 500 V	

Power supply - regulated, 240 W

Primary switchmode power supply, PFC, Single-phase

Input: AC 90–132 V; AC 185–264 V; DC 300–350 V

Output: 24 V - adjustable



Dimensions

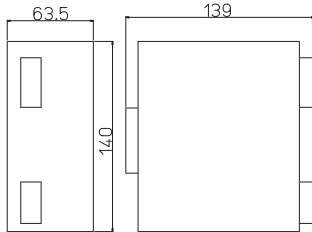

PIN assignment

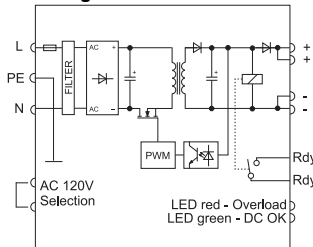

Derating

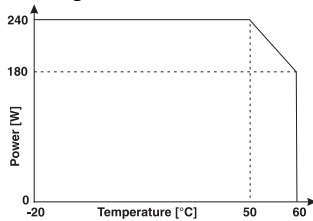

Parallel mode

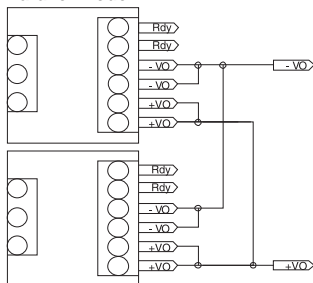

Description	Part-No.	Type	PU	
Screw terminal, pluggable				
Output voltage/current	DC 24 V; 10 A	722785	CPSB1-240-24R	1
	DC 48 V; 5 A	722786	CPSB1-240-48R	1

Input	CPSB1-240-24R	CPSB1-240-48R
Nominal voltage	AC 120 / 230 V (manual)	
Operation voltage range	AC 90–132 V / AC 185–264 V; DC 300–350 V	
Line frequency	47 – 63 Hz	
Rated current	U _I = AC 115 V: 3.5 A / U _I = AC 230 V: 1.8 A	
Inrush current	U _I = AC 115 V: 30 A / U _I = AC 230 V: 35 A	
Internal fuse	T6, 3 A / AC 250 V	
External fuse	Mini-circuit breaker: C 10 A	
Power Factor Correction P.F.C.	>0.6	

Output	CPSB1-240-24R	CPSB1-240-48R
Rated voltage output	DC 24 V	DC 48 V
Rated current output	10 A	5 A
Max. output current	15 A (30 s)	7.5 A (30 s)
Peak output current	25 A (400 ms)	
Voltage trim range	23/27.5 V	45/55 V
Accuracy	–	
Line regulation	–	
Load regulation	1 %	
Rise time	–	
Temperature coefficient	–	
Ripple & Noise	50 mV	
Hold up time	>30 ms (120 V); >60 ms (230 V)	
Status indication DC ON LED green	≥21.6 V	≥43.2 V
Status indication DC LOW LED red	≤21.6 V	≤43.2 V
Parallel mode	Yes, decoupling diode contained internally	
Efficiency	89 %	90 %
Low power loss	<26 W	
Rated over load protection	yes	
Over voltage protection	yes	
Short circuit characteristics	Hiccup-mode	

General		
Switching frequency	–	
Insulation voltage input/output	AC 3.0 kV _{eff}	
Insulation voltage input / ground	AC 1.5 kV _{eff}	
Insulation voltage output / ground	AC 0.5 kV _{eff}	
Insulation resistance at DC 500 V	– MΩ	
Operation temperature range	-20 °C – 60 °C (derating)	
Derating	>50°C: -6 W / °C	
Storage temperature range	-25 °C – 85 °C	
M.T.B.F.	>500000 h to SN29500 / >150000 h to MIL standard HDBK 217F	
Relative humidity	–	
Dimensions (w x h x d) in mm	63.5 x 140.0 x 139.0	
Cooling	Air convection	
Housing material	Aluminium	
Field installation	rail TS 35 (EN 50022)	
Application height	– m	
Installation position	vertical	
Protection class	IP 20 (IEC529, EN60529)	
Overvoltage category	III	
Pollution degree	2	
Protection class	–	
Weight (kg/piece)	0.720	
Termination	Screw terminal: 0.2–2.5 mm ² - pluggable	
Approvals	UL, cUL: UL 508, IEC 950, EN 60950, UL 60950 CE: EN 61000-4-2/3/4/5/6/11, EN 61000-6-2, EN 601000-6-4, EN 50178, EN 61558, EN 50081-1, EN 50082-2, EN 50022 Class B	

Monitoring	
DC ON Control (Rdy)	Normally open
Switching voltage	AC 300 V / DC 150 V
Switching current	AC/DC 1 A
Switching capacity	300 VA / 30 W
Insulation voltage	AC 500 V

Power supply - regulated, 240 W, 2-phase

Primary switchmode power supply, PFC, 1- / 2-phase

Input: Wide range input AC 187 V - 550 V; DC 270 V - 725 V

Output: 24 V - adjustable



Dimensions

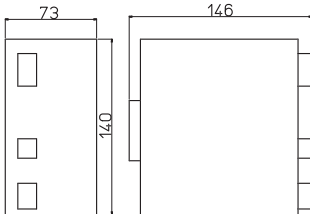

PIN assignment

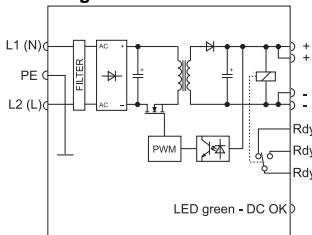

Derating

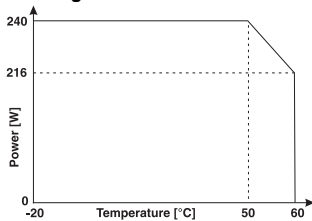

Parallel mode

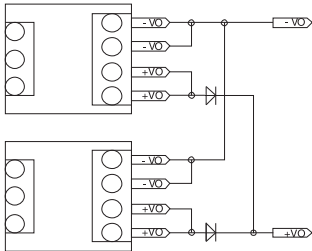

Description	Part-No.	Type	PU
Screw terminal, pluggable			
Output voltage/current	DC 24 V; 10 A	722984	CPSB2-240-24
			1
Input		CPSB2-240-24	
Nominal voltage	AC 200–500 V		
Operation voltage range	AC 187–550 V; DC 270–725 V		
Line frequency	47 – 63 Hz		
Rated current	U _i = AC 200 V: 2.0 A / U _i = AC 500 V: 1.0 A		
Inrush current	<AC 40 A		
Internal fuse	–		
External fuse	Mini-circuit breaker: B 10 A, C 6 A		
Power Factor Correction P.F.C.	>0.8		
Output			
Rated voltage output	DC 24 V		
Rated current output	10 A		
Max. output current	12 A		
Peak output current	30 A; 500 ms		
Voltage trim range	23/27.5 V		
Accuracy	–		
Line regulation	–		
Load regulation	<1 %		
Rise time	–		
Temperature coefficient	–		
Ripple & Noise	<80 mV pp		
Hold up time	>20 ms (AC 200 V); >120 ms (AC 500 V)		
Status indication DC ON LED green	≥21.6 V		
Status indication DC LOW LED red	≤21.6 V		
Parallel mode	Yes, with external decoupling diode		
Efficiency	>89 %		
Low power loss	<29 W max.		
Rated over load protection	yes		
Over voltage protection	yes		
Short circuit characteristics	Hiccup-mode		
General			
Switching frequency	–		
Insulation voltage input/output	AC 3.0 kV _{eff}		
Insulation voltage input / ground	AC 2.0 kV _{eff}		
Insulation voltage output / ground	AC 0.5 kV _{eff}		
Insulation resistance at DC 500 V	– MΩ		
Operation temperature range	-20 °C – 60 °C (derating)		
Derating	>50°C: -2.4 W / °C		
Storage temperature range	-25 °C – 85 °C		
M.T.B.F.	–		
Relative humidity	–		
Dimensions (w x h x d) in mm	73.0 x 140.0 x 146.0		
Cooling	Air convection		
Housing material	Aluminium		
Field installation	rail TS 35 (EN 50022)		
Application height	– m		
Installation position	vertical		
Protection class	IP 20 (IEC529, EN60529)		
Overvoltage category	II		
Pollution degree	2		
Protection class	–		
Weight (kg/piece)	1.100		
Termination	Screw terminal: 0.2–2.5 mm ² - pluggable		
Approvals	UL, cUL: UL 508, IEC 950, EN 60950 CE: EN 61000-4-2/3/4/5/6/11, EN 61000-6-2, EN 601000-6-4, EN 50178, EN 61558, EN 50081-1, EN 50082-2, EN 55022 Class B		
Monitoring			
DC ON Control (Rdy)	1 changeover contact		
Switching voltage	AC 300 V / DC 150 V		
Switching current	AC/DC 1 A		
Switching capacity	300 VA / 30 W		
Insulation voltage	AC 500 V		

Power supply - regulated, 240 W, 3-phase

Primary switchmode power supply, PFC, 3-phase

Input: Wide range input AC 400 - 500 V

Output: 24 V - adjustable



Dimensions

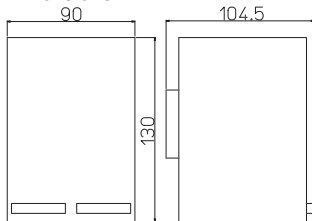

PIN assignment

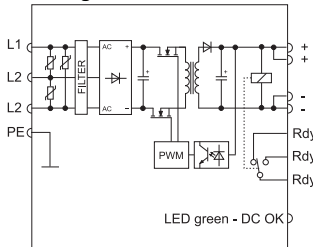

Derating

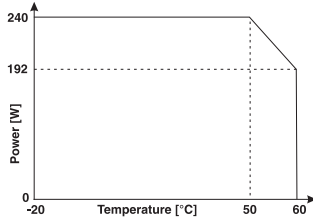

Parallel mode

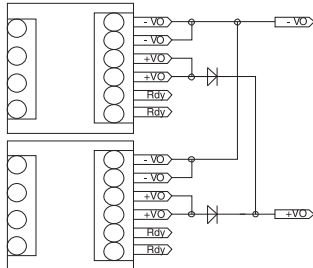

Description	Part-No.	Type	PU
Screw terminal			
Output voltage/current	DC 24 V; 10 A	722799	CPSB3-240-24
Input			
CPSB3-240-24			
Nominal voltage	3x AC 400–500 V		
Operation voltage range	3x AC 340–550 V; 3x DC 507–770 V		
Line frequency	47 – 63 Hz		
Rated current	U _I = AC 400 V: 1.3 A / U _I = AC 500 V: 1.1 A		
Inrush current	<AC 30 A		
Internal fuse	–		
External fuse	Mini-circuit breaker: 3x B 10 A, C 6 A		
Power Factor Correction P.F.C.	>0.6		
Output			
Rated voltage output	DC 24 V		
Rated current output	10 A @ 45 °C (UL508)		
Max. output current	14 A		
Peak output current	20 A		
Voltage trim range	24/28 V		
Accuracy	–		
Line regulation	–		
Load regulation	<1 %		
Rise time	–		
Temperature coefficient	–		
Ripple & Noise	50 mV pp		
Hold up time	>11 ms (AC 500 V)		
Status indication DC ON LED green	≥21.6 V		
Status indication DC LOW LED red	≤21.6 V		
Parallel mode	Yes, with external decoupling diode		
Efficiency	>90 % (AC 400 V)		
Low power loss	27 W max.		
Rated over load protection	yes		
Over voltage protection	yes		
Short circuit characteristics	Hiccup-mode		
General			
Switching frequency	–		
Insulation voltage input/output	AC 3.0 kV _{eff}		
Insulation voltage input / ground	AC 2.0 kV _{eff}		
Insulation voltage output / ground	AC 0.5 kV _{eff}		
Insulation resistance at DC 500 V	– MΩ		
Operation temperature range	-20 °C – 60 °C (derating)		
Derating	>50°C: -4.8 W / °C		
Storage temperature range	-25 °C – 85 °C		
M.T.B.F.	>500000 h to SN29500 / >150000 h to MIL standard HDBK 217F		
Relative humidity	–		
Dimensions (w x h x d) in mm	90.0 x 130.0 x 104.5		
Cooling	Air convection		
Housing material	Aluminium		
Field installation	rail TS 35 (EN 50022)		
Application height	– m		
Installation position	vertical		
Protection class	IP 20 (IEC529, EN60529)		
Overvoltage category	II		
Pollution degree	2		
Protection class	–		
Weight (kg/piece)	0.700		
Termination	Screw terminal: 0.2–4.0 mm ²		
Approvals	UL, cUL: UL 508, IEC 950, EN 60950 CE: EN 61000-4-2/3/4/5/6/11, EN 61000-6-2, EN 601000-6-4, EN 50178, EN 61558, EN 50081-1, EN 50082-2, EN 55022 Class B		
Monitoring			
DC ON Control (Rdy)	Changeover contact		
Switching voltage	AC 300 V / DC 150 V		
Switching current	AC/DC 1 A		
Switching capacity	300 VA / 30 W		
Insulation voltage	AC 500 V		

Power supply - regulated, 240 W, 3-phase

Primary switchmode power supply, PFC, 3-phase

Input: Wide range input AC 340 V - 576 V; DC 480 V - 820 V

Output: 24–48 V - adjustable



Dimensions

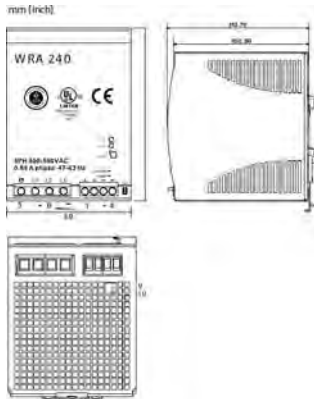

PIN assignment

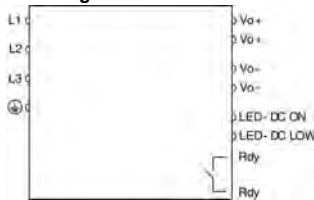

Derating

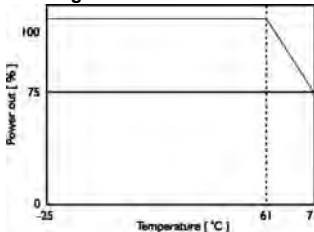

Parallel mode

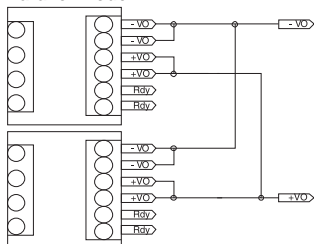

Description	Part-No.	Type	PU	
Screw terminal				
Output voltage/current	DC 24 V; 10 A	722804	WRA 240-24	1
	DC 48 V; 5 A	722808	WRA 240-48	1

Input	WRA 240-24	WRA 240-48
Nominal voltage		3x AC 340–500 V
Operation voltage range	3x AC 340–575 V; 3x DC 480–820 V	
Line frequency	47 – 63 Hz	
Rated current	U _I = AC 380 V: 0.85 A / U _I = AC 500 V: 0.7 A	
Inrush current	20 A	
Internal fuse	3xT2, 0 A / AC 600 V	
External fuse	Mini-circuit breaker: 3x B 5 A	
Power Factor Correction P.F.C.	0.6	

Output	WRA 240-24	WRA 240-48
Rated voltage output		DC 24 V
Rated current output	10 A	5 A
Max. output current	–	
Peak output current	–	
Voltage trim range	22.5/28.5 V	47–56 V
Accuracy	1 %	
Line regulation	±1 %	
Load regulation	Single ±1 %, Parallel ±5 %	
Rise time	1 s	
Temperature coefficient	±0.03 % / °C	
Ripple & Noise	100 mV	
Hold up time	min. 20 ms	
Status indication DC ON LED green	≥17.6–19.4 V	≥37–43 V
Status indication DC LOW LED red	≤17.6–19.4 V	≤37–43 V
Parallel mode	yes, max. 2 units at 90% load current, manual switch S/P	
Efficiency	90 %	91 %
Low power loss	30 W	24 W
Rated over load protection	115 - 135 %, temperature: disconnection at 100–110°C and automatic activation when cool off	

Over voltage protection	125–137 %	125–142 %
Short circuit characteristics	Hiccup-mode	

General		
Switching frequency	approx. 25 kHz	
Insulation voltage input/output	AC 3.0 kV _{eff}	
Insulation voltage input / ground	AC 1.5 kV _{eff}	
Insulation voltage output / ground	–	
Insulation resistance at DC 500 V	100 MΩ	
Operation temperature range	-25 °C – 71 °C (derating)	
Derating	Capacity: -2.5% / °C starting at +61 °C	
Storage temperature range	-25 °C – 85 °C	
M.T.B.F.	488000 h	519000 h
Relative humidity	20–95% RH	
Dimensions (w x h x d) in mm	89.0 x 123.6 x 117.5	
Cooling	Air convection	
Housing material	Metal	
Field installation	rail TS 35 (EN 50022)	
Application height	3000 m	
Installation position	vertical	
Protection class	IP 20	
Overvoltage category	II	
Pollution degree	2	
Protection class	–	
Weight (kg/piece)	1.100	
Termination	Screw terminal: 0.2–5.0 mm ²	
Approvals	UL: UL 508 listed; cUL: UL 60950-1 accepted; TÜV: EN 60950-1, CE: EN 61000-6-3 / EN 55022 Class B, EN 61000-3-2, EN 61000-3-3, EN 61000-6-2, EN 55024	

Monitoring		
DC ON Control (Rdy)	Normally open	–
Switching voltage	DC 60 V	–
Switching current	max. 300 mA	–
Switching capacity	–	–
Insulation voltage	DC 500 V	–

Power supply - regulated, 480 W

Primary switchmode power supply, PFC, Single-phase

Input: Wide range input AC 90 - 264 V; DC 120 - 370 V

Output: 24 V / 48 V - adjustable



Dimensions

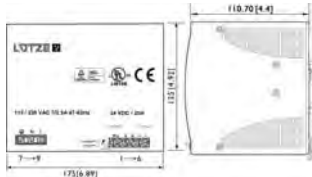

PIN assignment

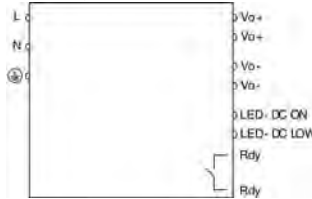

Derating

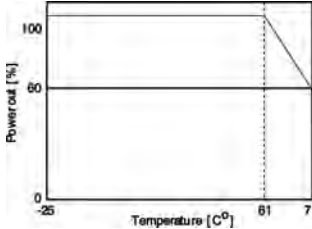

Parallel mode

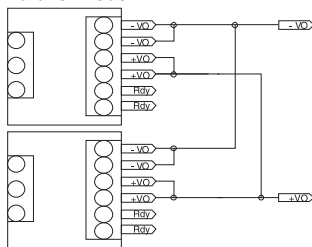

Description	Part-No.	Type	PU	
Screw terminal				
Output voltage/current	DC 24 V; 20 A	722782	DRA 480-24A	1
	DC 48 V; 10 A	722779	DRA 480-48A	1

Input	DRA 480-24A	DRA 480-48A
Nominal voltage	AC 115 / 230 V (auto select)	
Operation voltage range	AC 90–264 V; DC 120–370 V	
Line frequency	47 – 63 Hz	
Rated current	U _i = AC 115 V: 4.8 A / U _i = AC 230 V: 2.45 A	
Inrush current	U _i = AC 115 V: 25 A / U _i = AC 230 V: 50 A	
Internal fuse	T10 A / AC 250 V	
External fuse	Mini-circuit breaker: B 16 A	
Power Factor Correction P.F.C.	0.99	

Output	DRA 480-24A	DRA 480-48A
Rated voltage output	DC 24 V	DC 48 V
Rated current output	20 A	10 A
Max. output current	–	
Peak output current	–	
Voltage trim range	22.5–28.5 V	47/56 V
Accuracy	±1 %	
Line regulation	±0.5 %	
Load regulation	Single ±0.5 %, Parallel ±5 %	
Rise time	1 s	
Temperature coefficient	±0.03 % / °C	
Ripple & Noise	100 mV	
Hold up time	min. 30 ms	
Status indication DC ON LED green	≥17.6–19.4 V	≥37–40 V
Status indication DC LOW LED red	≤17.6–19.4 V	≤37–43 V
Parallel mode	max. 3 units at 90% load current, manual switch	
Efficiency	89 %	90 %
Low power loss	63 W	60 W
Rated over load protection	120–140 %	
Over voltage protection	125–137 %	119–131 %
Short circuit characteristics	Current limit	

General			
Switching frequency	approx. 60 kHz		
Insulation voltage input/output	AC 3.0 kV _{eff}		
Insulation voltage input / ground	AC 1.5 kV _{eff}		
Insulation voltage output / ground	–		
Insulation resistance at DC 500 V	100 MΩ		
Operation temperature range	-25 °C – 71 °C (derating)		
Derating	-4% / °C starting at 61 °C		
Storage temperature range	-25 °C – 85 °C		
M.T.B.F.	403000 h		416000 h
Relative humidity	20–95% RH		
Dimensions (w x h x d) in mm	175.0 x 125.0 x 116.0		
Cooling	Air convection		
Housing material	metal		
Field installation	rail TS 35 (EN 50022)		
Application height	2000 m		
Installation position	vertical		
Protection class	IP 20		
Overvoltage category	II		
Pollution degree	2		
Protection class	–		
Weight (kg/piece)	1.920		
Termination	Screw terminal: 0.2–6.0 mm ²		
Approvals	UL: UL 508 listed; cUL: UL 60950-1 accepted; TÜV: EN 60950-1, CE: EN 61000-6-3 / EN 55022 Class B, EN 61000-3-2, EN 61000-3-3, EN 61000-6-2, EN 55024		

Monitoring			
DC ON Control (Rdy)	Normally open		–
Switching voltage	DC 60 V		–
Switching current	max. 300 mA		–
Switching capacity			–
Insulation voltage	DC 500 V		–

Power supply - regulated, 480 W, 1-phase

Primary switchmode power supply, PFC, Single-phase

Input: AC 90-132 V; AC 187-264 V

Output: 24 V - adjustable



Dimensions

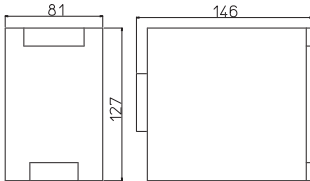

PIN assignment

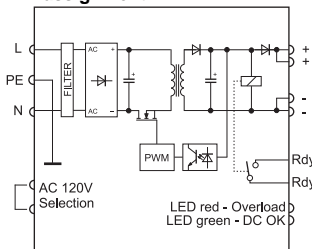

Derating

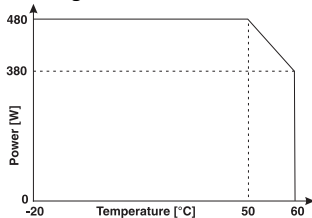

Parallel mode

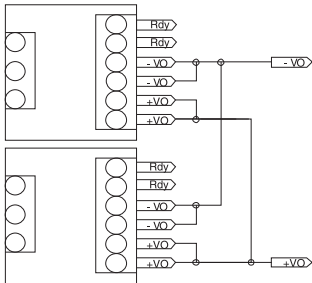

Description	Part-No.	Type	PU
Screw terminal			
Output voltage/current	DC 24 V; 20 A	722986	CPSB1-480-24R
			1
Input			
CPSB1-480-24R			
Nominal voltage	AC 120 V / AC 240 V		
Operation voltage range	AC 90–132 V / AC 187–264 V		
Line frequency	47 – 63 Hz		
Rated current	U _I = AC 120 V: 6 A / U _I = AC 230 V: 3.5 A		
Inrush current	<AC 35 A		
Internal fuse	–		
External fuse	Mini-circuit breaker: C 16 A		
Power Factor Correction P.F.C.	>0.6		
Output			
Rated voltage output	DC 24 V		
Rated current output	20 A		
Max. output current	30 A, 5 s		
Peak output current	>55 A; 5 s		
Voltage trim range	24/48 V		
Accuracy	–		
Line regulation	–		
Load regulation	<1 %		
Rise time	–		
Temperature coefficient	–		
Ripple & Noise	100 mV pp		
Hold up time	>35 ms (AC 240 V)		
Status indication DC ON LED green	≥21.6 V		
Status indication DC LOW LED red	≤21.6 V		
Parallel mode	Yes		
Efficiency	>92 % (AC 240 V)		
Low power loss	<45 W		
Rated over load protection	yes		
Over voltage protection	yes		
Short circuit characteristics	Hiccup-mode		
General			
Switching frequency	–		
Insulation voltage input/output	AC 3.0 kV _{eff}		
Insulation voltage input / ground	AC 2.0 kV _{eff}		
Insulation voltage output / ground	AC 0.7 kV _{eff}		
Insulation resistance at DC 500 V	– MΩ		
Operation temperature range	-20 °C – 60 °C (derating)		
Derating	>50°C: -10 W / °C		
Storage temperature range	-25 °C – 85 °C		
M.T.B.F.	–		
Relative humidity	–		
Dimensions (w x h x d) in mm	81.0 x 127.0 x 146.0		
Cooling	Air convection		
Housing material	Aluminium		
Field installation	rail TS 35 (EN 50022)		
Application height	– m		
Installation position	vertical		
Protection class	IP 20 (IEC529, EN60529)		
Overvoltage category	II		
Pollution degree	2		
Protection class	–		
Weight (kg/piece)	1.100		
Termination	Screw terminal: 0.2–6.0 mm ²		
Approvals	UL, cUL: UL 508, IEC 950, EN 60950 CE: EN 61000-4-2/3/4/5/6/11, EN 61000-6-2, EN 601000-6-4, EN 50178, EN 61558, EN 50081-1, EN 50082-2, EN 55022 Class B		
Monitoring			
DC ON Control (Rdy)	Normally open		
Switching voltage	AC 300 V / DC 150 V		
Switching current	AC/DC 1 A		
Switching capacity	300 VA / 30 W		
Insulation voltage	AC 500 V		

Power supply - regulated, 480 W, 3-phase

Primary switchmode power supply, PFC, 3-phase

Input: Wide range input AC 340 - 576 V; DC 480 - 820 V

Output: 24 V / 48 V - adjustable



Dimensions

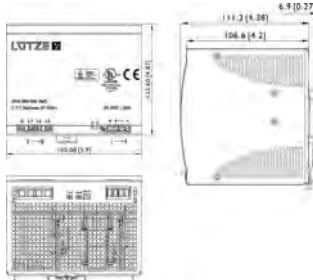

PIN assignment

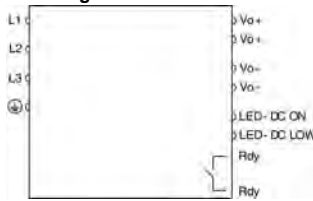

Derating

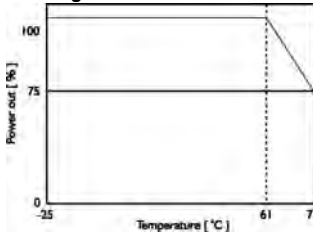

Parallel mode

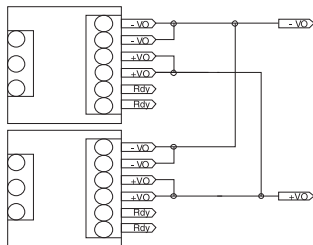

Description	Part-No.	Type	PU	
Screw terminal				
Output voltage/current	DC 24 V; 20 A	722805	WRA 480-24	1
	DC 48 V; 10 A	722809	WRA 480-48	1

Input	WRA 480-24	WRA 480-48
Nominal voltage	3x AC 380–500 V	
Operation voltage range	3x AC 340–576 V; 3x DC 480–820 V	
Line frequency	47 – 63 Hz	
Rated current	U _I = AC 400 V: 1.5 A / U _I = AC 480 V: 1.2 A	
Inrush current	20 A	
Internal fuse	T3, 15 A / per phase	
External fuse	Mini-circuit breaker: 3x B 10 A, C 6 A	
Power Factor Correction P.F.C.	0.7	

Output	DC 24 V	DC 48 V
Rated voltage output	DC 24 V	DC 48 V
Rated current output	20 A	10 A
Max. output current	–	
Peak output current	–	
Voltage trim range	22.5 –28.5 V	47/56 V
Accuracy	1 %	
Line regulation	±1 %	
Load regulation	Single ±1 %, Parallel ±5 %	
Rise time	–	
Temperature coefficient	±0.03 % / °C	
Ripple & Noise	100 mV	
Hold up time	min. 20 ms	
Status indication DC ON LED green	≥17.6–19.4 V	≥37–43 V
Status indication DC LOW LED red	≤17.6–19.4 V	≤37–43 V
Parallel mode	max. 3 units at 90% load current, manual switch	
Efficiency	90 %	
Low power loss	58 W	55 W
Rated over load protection	115–135 %	
Over voltage protection	125–137 %	125–142 %
Short circuit characteristics	Current limit (C) / Hiccup-mode (D), with switch C/D	

General		
Switching frequency	approx. 80 kHz	
Insulation voltage input/output	AC 3.0 kV _{eff}	
Insulation voltage input / ground	AC 1.5 kV _{eff}	
Insulation voltage output / ground	–	
Insulation resistance at DC 500 V	100 MΩ	
Operation temperature range	-25 °C – 71 °C (derating)	
Derating	-2.5% / °C starting at 61 °C	
Storage temperature range	-25 °C – 85 °C	
M.T.B.F.	411000 h	423000 h
Relative humidity	20–95% RH	
Dimensions (w x h x d) in mm	150.0 x 125.0 x 116.0	
Cooling	Air convection	
Housing material	metal	
Field installation	rail TS 35 (EN 50022)	
Application height	3000 m	
Installation position	vertical	
Protection class	IP 20	
Overvoltage category	II	
Pollution degree	2	
Protection class	–	
Weight (kg/piece)	1.750	
Termination	Screw terminal: 0.2–6.0 mm ²	
Approvals	UL: UL 508 listed; cUL: UL 60950-1 accepted; TÜV: EN 60950-1; CE: EN 61000-6-3 / EN 55022 Class B, EN 61000-3-2, EN 61000-3-3, EN 61000-6-2, EN 55024	

Monitoring		
DC ON Control (Rdy)	Normally open	–
Switching voltage	DC 60 V	–
Switching current	max. 300 mA	–
Switching capacity	–	–
Insulation voltage	DC 500 V	–

Power supply - regulated, 480 W, 3-phase

Primary switchmode power supply, PFC, 3-phase

Input: Wide range input AC 340 - 550 V

Output: 24 V - adjustable



Dimensions

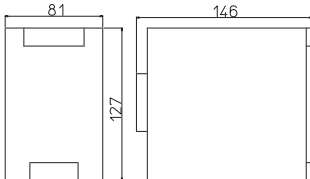

PIN assignment

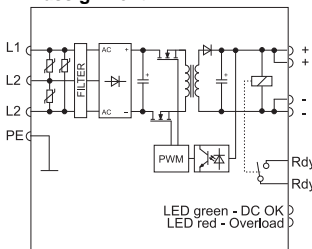

Derating

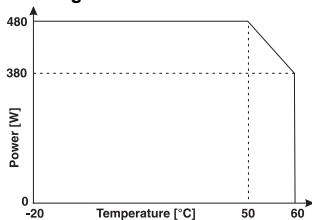

Parallel mode

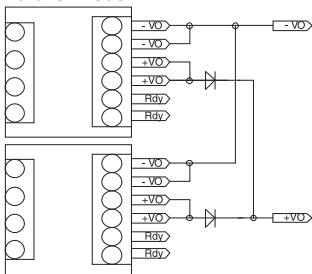

Description	Part-No.	Type	PU
Screw terminal			
Output voltage/current	DC 24 V; 20 A	722800	CPSB3-500-24
			1
Input			
CPSB3-500-24			
Nominal voltage	3x AC 400–500 V		
Operation voltage range	3x AC 340–550 V		
Line frequency	47 – 63 Hz		
Rated current	U _i = AC 400 V: 1.3 A / U _i = AC 500 V: 1.1 A		
Inrush current	<AC 40 A		
Internal fuse	–		
External fuse	Mini-circuit breaker: 3x B 16 A, C 10 A		
Power Factor Correction P.F.C.	>0.6		
Output			
Rated voltage output	DC 24 V		
Rated current output	20 A		
Max. output current	55 A, 5 s		
Peak output current	–		
Voltage trim range	24/28 V		
Accuracy	–		
Line regulation	–		
Load regulation	<1 %		
Rise time	–		
Temperature coefficient	–		
Ripple & Noise	100 mV pp		
Hold up time	>15 ms (AC 400 V)		
Status indication DC ON LED green	≥21.6 V		
Status indication DC LOW LED red	≤21.6 V		
Parallel mode	Yes, with external decoupling diode		
Efficiency	>94 % (AC 400 V)		
Low power loss	30 W		
Rated over load protection	yes		
Over voltage protection	yes		
Short circuit characteristics	Hiccup-mode		
General			
Switching frequency	–		
Insulation voltage input/output	AC 3.0 kV _{eff}		
Insulation voltage input / ground	AC 2.0 kV _{eff}		
Insulation voltage output / ground	AC 0.5 kV _{eff}		
Insulation resistance at DC 500 V	– MΩ		
Operation temperature range	-20 °C – 60 °C (derating)		
Derating	>50°C: -10 W / °C		
Storage temperature range	-25 °C – 85 °C		
M.T.B.F.	>500000 h to SN29500 / >150000 h to MIL standard HDBK 217F		
Relative humidity	–		
Dimensions (w x h x d) in mm	81.0 x 127.0 x 146.0		
Cooling	Air convection		
Housing material	Aluminium		
Field installation	rail TS 35 (EN 50022)		
Application height	– m		
Installation position	vertical		
Protection class	IP 20 (IEC529, EN60529)		
Overvoltage category	II		
Pollution degree	2		
Protection class	–		
Weight (kg/piece)	1,200		
Termination	Screw terminal: 0.2–6.0 mm ²		
Approvals	UL, cUL: UL 508, IEC 950, EN 60950 CE: EN 61000-4-2/3/4/5/6/11, EN 61000-6-2, EN 601000-6-4, EN 50178, EN 61558, EN 50081-1, EN 50082-2, EN 55022 Class B		
Monitoring			
DC ON Control (Rdy)	Normally open		
Switching voltage	AC 300 V / DC 150 V		
Switching current	AC/DC 1 A		
Switching capacity	300 VA / 30 W		
Insulation voltage	AC 500 V		

Power supply - regulated, 720 W, 3-phase

Primary switchmode power supply, PFC, 3-phase

Input: Wide range input AC 340 - 550 V

Output: 24 V - adjustable



Dimensions

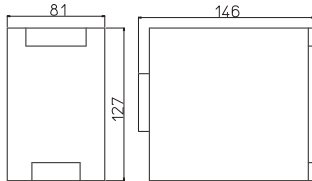

PIN assignment

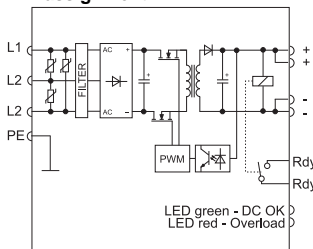

Derating

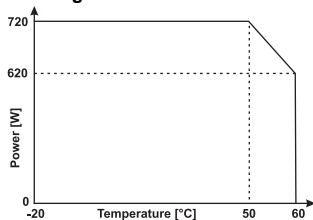

Parallel mode

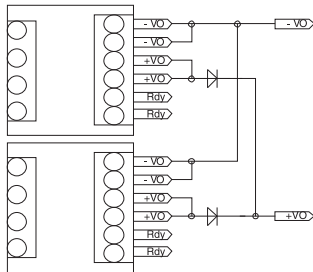

Description	Part-No.	Type	PU
Screw terminal			
Output voltage/current	DC 24 V; 30 A	722802	CPSB3-720-24
			1
Input			
CPSB3-720-24			
Nominal voltage		3x AC 400–500 V	
Operation voltage range		3x AC 340–550 V	
Line frequency		47 – 63 Hz	
Rated current		U _I = AC 400 V: 2.1 A / U _I = AC 500 V: 1.8 A	
Inrush current		<AC 10 A	
Internal fuse		–	
External fuse		Mini-circuit breaker: 3x B 16 A, C 10 A	
Power Factor Correction P.F.C.		>0.6	
Output			
Rated voltage output		DC 24 V	
Rated current output		30 A	
Max. output current		45 A, 5 s	
Peak output current		60 A, 5 s	
Voltage trim range		24/28 V	
Accuracy		–	
Line regulation		–	
Load regulation		<1 %	
Rise time		–	
Temperature coefficient		–	
Ripple & Noise		100 mV pp	
Hold up time		>15 ms (AC 400 V)	
Status indication DC ON LED green		≥21.6 V	
Status indication DC LOW LED red		≤21.6 V	
Parallel mode		Yes, with external decoupling diode	
Efficiency		>94 % (AC 400 V)	
Low power loss		<55 W max.	
Rated over load protection		> 90°C, auto-reset	
Over voltage protection		<33 V	
Short circuit characteristics		Hiccup mode, 5 s ON / 7 s OFF	
General			
Switching frequency		–	
Insulation voltage input/output		AC 3.0 kV _{eff}	
Insulation voltage input / ground		AC 2.0 kV _{eff}	
Insulation voltage output / ground		AC 1.0 kV _{eff}	
Insulation resistance at DC 500 V		– MΩ	
Operation temperature range		-20 °C – 60 °C	
Derating		>50°C: -10 W / °C	
Storage temperature range		-25 °C – 85 °C	
M.T.B.F.		>500000 h to SN29500 / >150000 h to MIL standard HDBK 217F	
Relative humidity		–	
Dimensions (w x h x d) in mm		81.0 x 127.0 x 146.0	
Cooling		Air convection, Forced cooling >50°C	
Housing material		Aluminium	
Field installation		rail TS 35 (EN 50022)	
Application height		– m	
Installation position		vertical	
Protection class		IP 20 (IEC529, EN60529)	
Overvoltage category		II	
Pollution degree		2	
Protection class		–	
Weight (kg/piece)		1.200	
Termination		Screw terminal: 0.2–6.0 mm ²	
Approvals		UL, cUL: UL 508, IEC 950, EN 60950 CE: EN 61000-4-2/3/4/5/6/11, EN 61000-6-2, EN 601000-6-4, EN 50178, EN 61558, EN 50081-1, EN 50082-2, EN 55022 Class B	
Monitoring			
DC ON Control (Rdy)		Normally open	
Switching voltage		AC 300 V / DC 150 V	
Switching current		AC/DC 1 A	
Switching capacity		300 VA / 30 W	
Insulation voltage		AC 500 V	

Power supply - regulated, 960 W, 3-phase

Primary switchmode power supply, PFC, 3-phase
 Input: Wide range input AC 340 - 576 V; DC 480 - 820 V
 Output: 24 V / 48 V - adjustable



Dimensions



PIN assignment

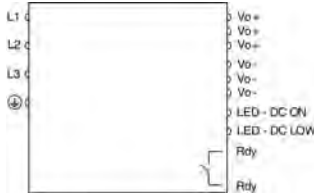

Derating

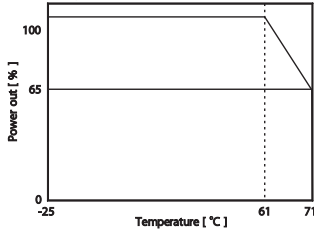

Parallel mode

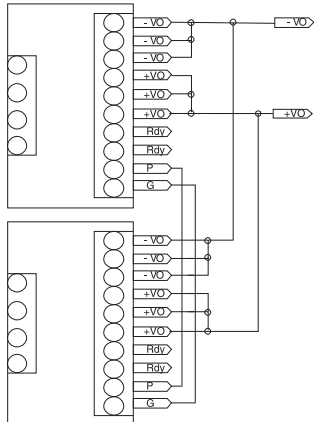

Description	Part-No.	Type	PU	
Screw terminal				
Output voltage/current	DC 24 V; 40 A	722806	WRA 960-24	1
	DC 48 V; 20 A	722810	WRA 960-48	1
Input				
	WRA 960-24	WRA 960-48		
Nominal voltage	3x AC 400–500 V			
Operation voltage range	3x AC 340–575 V; 3x DC 480–820 V			
Line frequency	47 – 63 Hz			
Rated current	U _i = AC 400 V: 2.4 A / U _i = AC 480 V: 1.6 A			
Inrush current	30 A			
Internal fuse	T6, 3 A / per phase			
External fuse	Mini-circuit breaker: 3x B 16 A, C 10 A			
Power Factor Correction P.F.C.	0.7			
Output				
Rated voltage output	DC 24 V		DC 48 V	
Rated current output	40 A		20 A	
Max. output current	–			
Peak output current	–			
Voltage trim range	22.5–28.5 V		47/56 V	
Accuracy	1 %			
Line regulation	±1 %			
Load regulation	Single ±1 %, Parallel ±5 %			
Rise time	1 s			
Temperature coefficient	±0.03 % / °C			
Ripple & Noise	80 mV			
Hold up time	15 ms			
Status indication DC ON LED green	≥17.6–19.4 V		≥37–43 V	
Status indication DC LOW LED red	≤17.6–19.4 V		≤37–43 V	
Parallel mode	max. 2 units at 90% load current, terminal P, G for current share			
Efficiency	92 %		93 %	
Low power loss	–			
Rated over load protection	Rated over load protection: 110 % –130 %			
Over voltage protection	125–137 %		125–142 %	
Short circuit characteristics	Hiccup-mode			
General				
Switching frequency	approx. 52 kHz			
Insulation voltage input/output	AC 3.0 kV _{eff}			
Insulation voltage input / ground	AC 1.5 kV _{eff}			
Insulation voltage output / ground	–			
Insulation resistance at DC 500 V	100 MΩ			
Operation temperature range	-25 °C – 71 °C (derating)			
Derating	-3.5 % / °C starting at 61°C			
Storage temperature range	-25 °C – 85 °C			
M.T.B.F.	352000 h		390000 h	
Relative humidity	20–95% RH			
Dimensions (w x h x d) in mm	276.0 x 125.0 x 118.0			
Cooling	Air convection			
Housing material	metal			
Field installation	rail TS 35 (EN 50022)			
Application height	3000 m			
Installation position	vertical			
Protection class	IP 20			
Overvoltage category	II			
Pollution degree	2			
Protection class	–			
Weight (kg/piece)	3.200			
Termination	Screw terminal: 0.2–6.0 mm ²			
Approvals	UL: UL 508 listed; cUL: UL 60950-1 accepted; TÜV: EN 60950-1, CE: EN 61000-6-3 / EN 55022 Class B, EN 61000-3-2, EN 61000-3-3, EN 61000-6-2, EN 55024			
Monitoring				
DC ON Control (Rdy)	Normally open		–	
Switching voltage	DC 60 V		–	
Switching current	max. 300 mA		–	
Switching capacity	–			
Insulation voltage	DC 500 V		–	

Power supply - regulated, 960 W, 3-phase

Primary switchmode power supply, PFC, 3-phase

Input: Wide range input AC 340 - 550 V

Output: 24 V / 48 V / 72 V



Dimensions

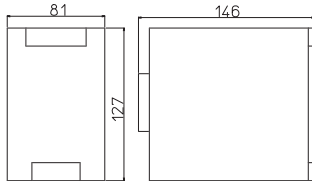

PIN assignment

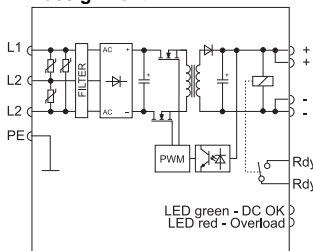

Derating

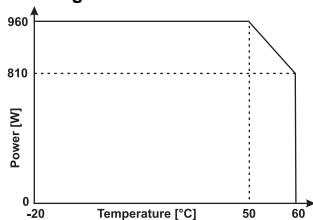

Parallel mode

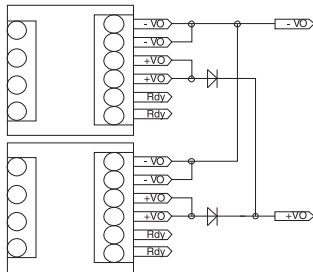

Description	Part-No.	Type	PU	
Screw terminal				
Output voltage/current	DC 24 V; 40 A	722811	CPSB3-960-24	1
	DC 48 V; 20 A	722812	CPSB3-960-48	1
	DC 72 V; 13.3 A	722813	CPSB3-960-72	1
Input				
	CPSB3-960-24	CPSB3-960-48	CPSB3-960-72	
Nominal voltage		3x AC 400–500 V		
Operation voltage range		3x AC 340–550 V		
Line frequency		47 – 63 Hz		
Rated current		U _I = AC 400 V: 2.8 A / U _I = AC 500 V: 2.2 A		
Inrush current		<AC 10 A		
Internal fuse		–		
External fuse		Mini-circuit breaker: 3x B 16 A, C 10 A		
Power Factor Correction P.F.C.		>0.6		
Output				
Rated voltage output	DC 24 V	DC 48 V	DC 72 V	
Rated current output	40 A	20 A	13.3 A	
Max. output current	>56 A (5 s)	>28 A (5 s)	>18.6 A (5 s)	
Peak output current	>90 A (5 s)	>70 A (5 s)	>40 A (5 s)	
Voltage trim range	24/28 V	45/55 V	72/84 V	
Accuracy		–		
Line regulation		–		
Load regulation	<2 %	<1.5 %	<1 %	
Rise time		–		
Temperature coefficient		–		
Ripple & Noise		<100 mV		
Hold up time		>10 ms (AC 400 V); >15 ms (AC 500 V)		
Status indication DC ON LED green	≥21.6 V	≥43.2 V	≥64.8 V	
Status indication DC LOW LED red	≤21.6 V	≤43.2 V	≤64.8 V	
Parallel mode		yes, with external diodes		
Efficiency		>94 %		
Low power loss		<61 W		
Rated over load protection		> 90°C, auto-reset		
Over voltage protection	<33 V	<60 V	<94 V	
Short circuit characteristics		Hiccup mode, 5 s ON / 10 s OFF		
General				
Switching frequency		–		
Insulation voltage input/output		AC 3.0 kV _{eff}		
Insulation voltage input / ground		AC 2.0 kV _{eff}		
Insulation voltage output / ground		AC 1.0 kV _{eff}		
Insulation resistance at DC 500 V		– MΩ		
Operation temperature range		-20 °C – 60 °C (derating)		
Derating		>50°C: -15 W / °C, UL 508: >45°C: -15 W / °C		
Storage temperature range		-25 °C – 85 °C		
M.T.B.F.		>500000 h to SN29500 / >150000 h to MIL standard HDBK 217F		
Relative humidity		–		
Dimensions (w x h x d) in mm		81.0 x 127.0 x 146.0		
Cooling		Air convection, Forced cooling >50°C		
Housing material		Aluminium		
Field installation		rail TS 35 (EN 50022)		
Application height		– m		
Installation position		vertical		
Protection class		IP 20 (IEC529, EN60529)		
Overvoltage category		II		
Pollution degree		2		
Protection class		–		
Weight (kg/piece)		1.200		
Termination		Input: screw terminal: 0.2-4.0 mm ² Output: screw terminal: 0.2-6.0 mm ²		
Approvals		UL, cUL: UL 508, IEC 950, EN 60950 CE: EN 61000-4-2/3/4/5/6/11, EN 61000-6-2, EN 601000-6-4, EN 50178, EN 61558, EN 50081-1, EN 50082-2, EN 55022 Class B		
Monitoring				
DC ON Control (Rdy)		Normally open		
Switching voltage		AC 300 V / DC 150 V		
Switching current		AC/DC 1 A		
Switching capacity		300 VA / 30 W		
Insulation voltage		AC 500 V		

Power supply - Redundant module

Redundant module 20 A with 2 inputs Potential-free signalling contact and Status LED per input Over- and undervoltage control



Dimensions

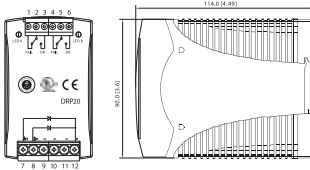

PIN assignment

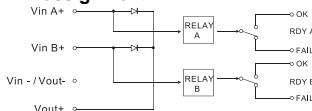

Use

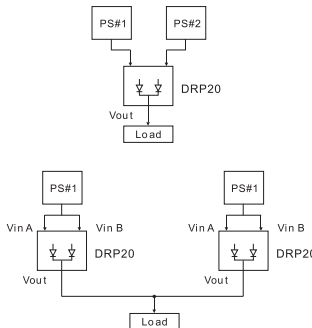

Description	Part-No.	Type	PU
Screw terminal			
Output voltage/current	DC 24 V; 20 A	722987	DRP 20-24
Input			
		DRP 20-24	
Nominal voltage	DC 24 V		
Operation voltage range	DC 21–28 V		
Inputs	2		
Rated current	max. 20 A in total		
Internal fuse	–		
External fuse	–		
Output			
Rated voltage output	DC 24 V		
Rated current output	20 A		
Max. output current	30 A, 5 s		
Voltage drop	0.5 V		
Inverse voltage	30 V		
Low power loss	Max. 10 W		
Status indication DC ON LED green	ON: DC input A or B OK / OFF: Error		
Rated over load protection	No		
Over voltage protection	No		
General			
Operation temperature range	-5°C – 70 °C		
Derating	–		
Storage temperature range	-25 °C – 85 °C		
M.T.B.F.	659000 h		
Dimensions (w x h x d) in mm	54.0 x 90.0 x 114.0		
Cooling	Air convection		
Housing material	Plastic		
Field installation	rail TS 35 (EN 50022)		
Application height	– m		
Installation postition	vertical		
Protection class	IP 20 (IEC529, EN60529)		
Overvoltage category	II		
Pollution degree	2		
Weight (kg/piece)	0.210		
Termination	Input: screw terminal: 0.2-4.0 mm ² Output: screw terminal: 0.2-6.0 mm ² Relay: screw terminal: 0.2-2.5 mm ²		
Approvals	UL, cUL: UL 508 listed, UL 60950-1 recognized CE: EN 550 22 Class B, EN 55024 CE: EN 61000-4-2/3/4/6/8, EN 61204-3		
Monitoring			
DC ON Control (Rdy)	Changeover contact per input No error: input voltage >20 V or <30 V, connection 2(5) - 3(6) closed Error: input voltage <20 V or >30 V, connection 2(5) - 1(4) closed		
Switching voltage	AC 300 V / DC 150 V		
Switching current	AC/DC 1 A		
Switching capacity	300 VA / 30 W		
Insulation voltage	AC 100 V		

Power supply - unregulated, 60–360 Watt

Power supply unit, Single-phase, unregulated, screw terminal

Input: AC 115 V / 230 V / 400 V

Output: DC 24 V



Dimensions

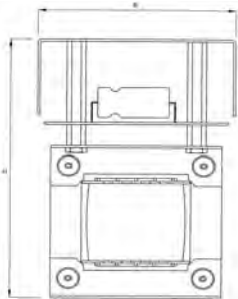

PIN assignment

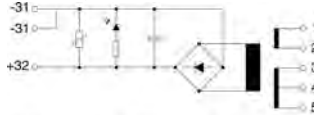

Voltage	Terminal	Contact bridge
115 V	1 u. 4	1 – 3 u. 2 – 4
230 V	1 u. 4	2 – 3
400 V	1 u. 5	2 – 3

Description	Part-No.	Type	PU	
Screw terminal				
Nominal voltage	DC 24V; 2.5A	722962	NG 24/2,5-2962	1
	DC 24 V; 5 A	722963	NG 24/5-2963	1
	DC 24 V; 10 A	722972	NG 24/10-2972	1
	DC 24 V; 15 A	722973	NG 24/15-2973	1

Input	NG 24/2,5-2962	NG 24/5-2963	NG 24/10-2972	NG 24/15-2973
Input voltage	AC 115 / 230 / 400 V			
Operation voltage range	AC 104–196 V / AC 207–224 V / AC 360–424 V			
Line frequency	47 – 63 Hz			
Rated current	1.6 A / 0.6 A / 0.4 A	2.4 A / 1.1 A / 0.6 A	5.0 A / 2.4 A / 1.8 A	6.0 A / 3.2 A / 2.0 A
Rated power	60 W	120 W	240 W	360 W
Recommended back-up fuse	115 V: 4 A / 230 V: 2 A / 400 V: 1 A	115 V: 4 A / 230 V: 2 A / 400 V: 2 A	115 V: 6 A / 230 V: 4 A / 400 V: 2 A	115 V: 10 A / 230 V: 6 A / 400 V: 4 A

Termination Screw terminal with additional flat connector: 0.5–6.0mm²

Output

Rated voltage output	DC 24 V			
Rated current output	2.5 A	5 A	10 A	15 A
Nominal voltage	at open-circuit 30.2 V, at full load: 20.4 V			
Line regulation	–			
Load regulation	–			
Transient recovery time	–			
Temperature coefficient	–			
Ripple	2.2–2.7 %		–	
Hold up time	–			
Status indication DC ON LED green	Yes			
Status indication DC LOW LED red	–			
Parallel mode	with 90% load current			
Efficiency	73 %	77 %	80 %	
Rated over load protection	No			
Short circuit characteristics	–			
Output circuit	Varistor and capacitor			
Termination	Screw terminal 0.5–10 mm ²			

General

Switching frequency	–			
Insulation voltage input/output	4.0 kV _{eff}			
Insulation class	T 40 / B			
Insulation class	according to VDE B, UL/CSA: class 130			
Operation temperature range	-25 °C – 80 °C			
Derating	–			
Storage temperature range	-40 °C – 80 °C			
Relative humidity	80% occasional condensation possible			
Dimensions (w x h x d) in mm	85 x 137 x 98	106 x 160 x 113	121 x 170 x 128	151 x 200 x 145
Cooling	Air convection			
Housing material	metal			
Field installation	Screw termination: 0.5–4.0 mm ²			
Assembly borehole	64 x 64.5 mm/M 5	83 x 80.5 mm/M 5	104 x 90 mm/M 5	90 x 122 mm/M 6
Cu application weight	0,62 kg/piece	0,6 kg/piece	0,9 kg/piece	1,5 kg/piece
Installation position	Optional			
Protection class	IP 00			
IP rating	I			
Weight (kg/piece)	2.300	4.900	7.500	9.000

Standards Transformer compliant with IEC 61-558, Output limit values compliant with EN 61 131-2 EMC compliant with EN 50 081-1 and EN 50 082-2, Main connection compliant with EN 61 000-3-2

Approvals cULus

Fixing

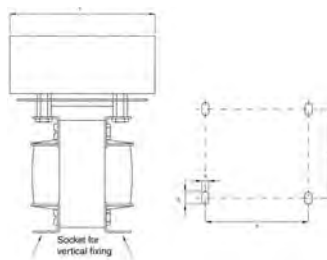

Power supply - unregulated, 72–240 Watt

Power supply unit, Single-phase, unregulated, screw terminal

Input: AC 230 V / 400 V

Output: DC 24 V



Dimensions

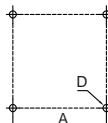
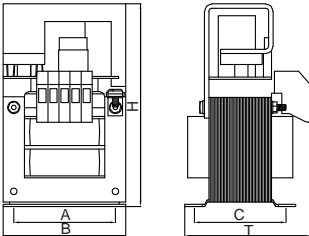

PIN assignment

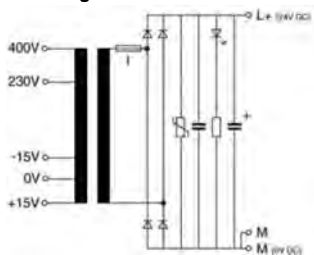

Description	Part-No.	Type	PU
Screw terminal			
Nominal voltage	722620	NG 24/3-2620 with fusing	1
	722621	NG 24/36-2621 with fusing	1
	722622	NG 24/10-2622 with fusing	1
Input			
	NG 24/3-2620 with fusing	NG 24/36-2621 with fusing	NG 24/10-2622 with fusing
Input voltage	AC 230 / 400 V		
Operation voltage range	AC 207–244 V / AC 360–424 V		
Line frequency	47 – 63 Hz		
Rated current	0.7 A / 0.5 A	1.2 A / 0.8 A	2.4 A / 1.6 A
Rated power	72 W	144 W	240 W
Recommended back-up fuse	2 A / 1 A	2 A / 2 A	4 A / 2 A
Termination	Screw terminal with additional flat connector: 0.5–6.0 mm ²		
Output			
Rated voltage output	–		
Rated current output	3 A	6 A	10 A
Nominal voltage	at open-circuit 30.2 V, at full load: 20.4 V		
Line regulation	–		
Load regulation	–		
Transient recovery time	–		
Temperature coefficient	–		
Ripple	< 5%		
Hold up time	–		
Status indication DC ON LED green	Yes		
Status indication DC LOW LED red	–		
Parallel mode	with 90% load current		
Efficiency	77 %		
Rated over load protection	yes		
Short circuit characteristics	–		
Output circuit	Varistor and capacitor		
Termination	Screw terminal: 0.5–4.0 mm ²		
General			
Switching frequency	–		
Insulation voltage input/output	4.0 kV _{eff}		
Insulation class	T 40 / B		
Insulation class	according to VDE B, UL/CSA: class 130		
Operation temperature range	–25 °C – 80 °C		
Derating	–		
Storage temperature range	–40 °C – 80 °C		
Relative humidity	80% occasional condensation possible		
Dimensions (w x h x d) in mm	84 x 146 x 77	96 x 156 x 103	120 x 174 x 102
Cooling	Air convection		
Housing material	metal		
Field installation	Screw terminal: 0.5–4.0 mm ²		
Assembly borehole	65 mm x 64 mm/M 4	86,5 mm x 84 mm/M 5	85 mm x 90 mm/M 5
Cu application weight	0,3 kg/piece	0,5 kg/piece	1 kg/piece
Installation position	Optional		
Protection class	IP 00		
IP rating	I		
Weight (kg/piece)	2.300	3.900	5.600
Standards	Transformer compliant with IEC 61-558, Output limit values compliant with EN 61 131-2 EMC compliant with EN 50 081-1 and EN 50 082-2, Main connection compliant with EN 61 000-3-2		
Approvals	cULus		

LOCC-Box / LOCC-Box-Net • Overview



Current range	Characteristic	Status output	Remote input	Bus connection	Software	Gateway	Part-Nr.
10, adjustable in 1 A-steps 1 A - 10 A	5, fast / medium/ slow-1/slow-2/ slow-3 5, fast / medium/ slow-1/slow-2/ slow-3 + 1, pro- grammable	active Low after Overload or short circuit active Low after Overload or short circuit + man. Off parametrizable	On- / Off via puls	Yes	LOCC-Pads	CANopen, USB, RS232	
•	•	•	•				716400
•	•		•				716401
•	•		•	•	•	•	716410

Accessories			
Module	Part-Nr.	Type	PU
Gateway (USB, CANopen, RS232)	716459	LOCC-Box-GW 7-6459	1
Supply terminal with break out for copper bus bar, increase the input current	716421	LOCC-Box-EKL 7-6421	2
Supply terminal without terminal	716422	LOCC-Box-DKL 7-6422	2
LOCC-Box empty housing without terminals	716424	LOCC-Box-DY 7-6424	2
Supply set (supply & end terminal block)	716425	LOCC-Box-ES 7-6425	1
0V-Collecting Terminal	716420	LOCC-Box-SK 7-6420	2
Jumber Comb			
Module	Part-Nr.	Type	PU
Jumber comb 8pole, 6A, white	716428	LOCC-Box-BKW 7-6428	5
Jumber comb 8pole, 6A, red	716429	LOCC-Box-BKR 7-6429	5
Jumber comb 8pole, 6A, blue	716430	LOCC-Box-BKB 7-6430	5
Jumber comb 16pole, 6A, white	716438	LOCC-Box-BKW 7-6438	5
Jumber comb 16pole, 6A, red	716439	LOCC-Box-BKW 7-6439	5
Jumber comb 16pole, 6A, blue	716440	LOCC-Box-BKW 7-6440	5
Marker Holder			
Module	Part-Nr.	Type	PU
Marker holder 5x5mm , 200 pcs., white	716431	LOCC-Box-BZW 7-6431	1
Marker holder 5x5mm, 200 pcs, red	716432	LOCC-Box-BZR 7-6432	1
Marker holder 5x5mm, 200 pcs, blue	716433	LOCC-Box-BZB 7-6433	1
Marker holder 5x5mm, 200 pcs, yellow	716434	LOCC-Box-BZG 7-6434	1
Marker holder 12x6mm ,120 pcs, white	716441	LOCC-Box-BZW 7-6441	1
Other			
Module	Part-Nr.	Type	PU
Copper bus bar 1m	716426	LOCC-Box-CU 7-6426	1
Covering Copper bus bar 1m	716427	LOCC-Box-AD 7-6427	1

Modular, flexible and safe: The LÜTZE Current Control System LO

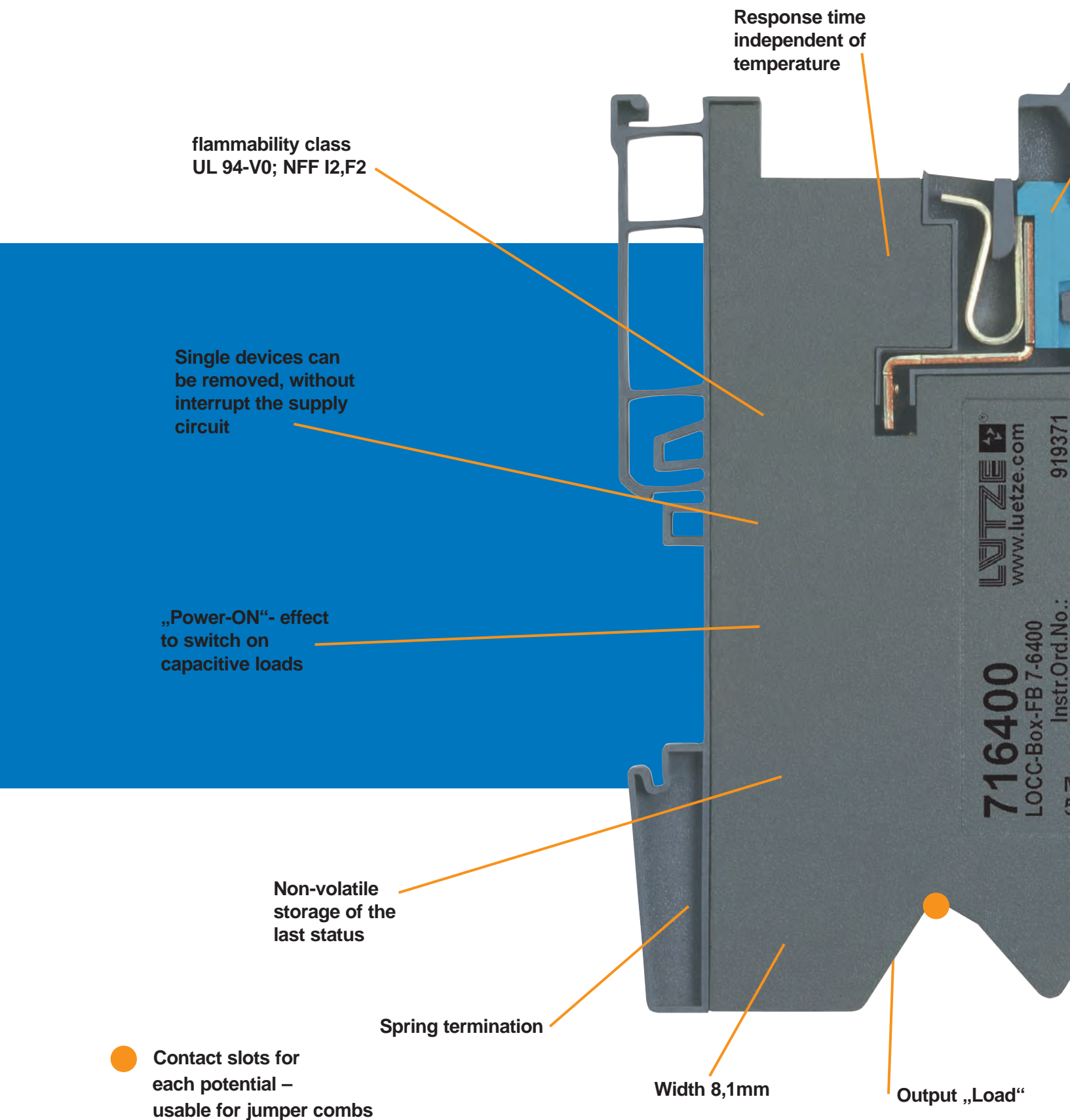

The intelligent LOCC-Box

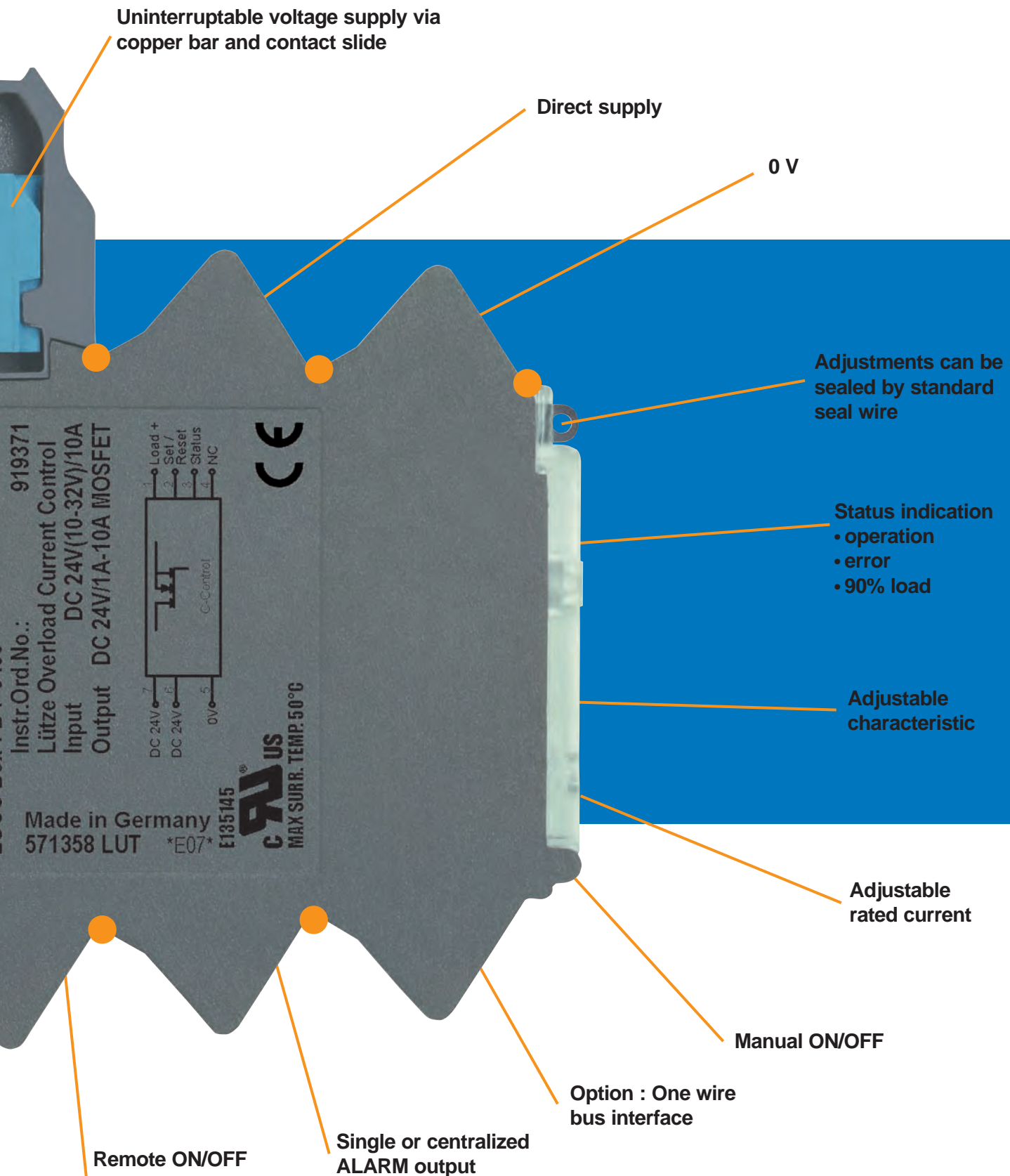

LOCC-Box / LOCC-Box-Net • Example Application

Standard Application

without supply set, art. no. 716425

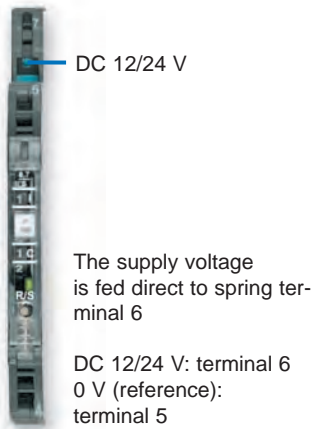

with supply set, art. no. 716425

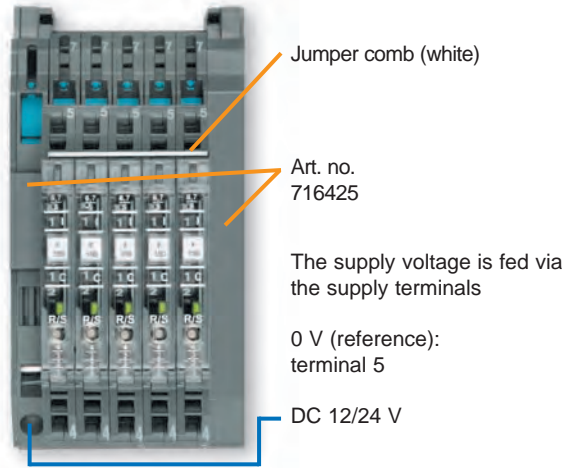

Use with additional supply terminals

Supply set, art. no. 716425 and supply terminal, art. no. 716421

The supply terminal is accessed via an aperture in the left hand side wall. This enables a variable positioning in the system construction. The maximum total current can thus be increased to 70 A.

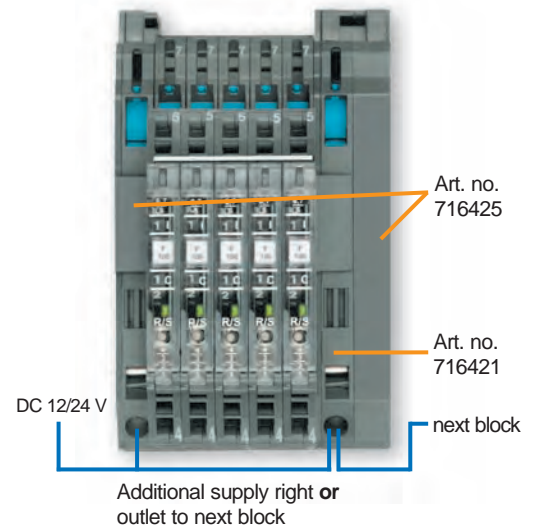

Individual construction with distance terminal

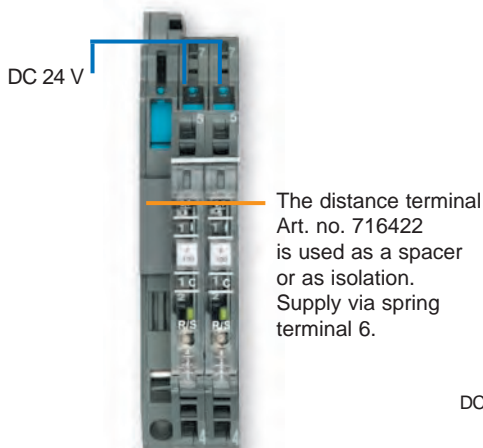

Empty housing as placeholder

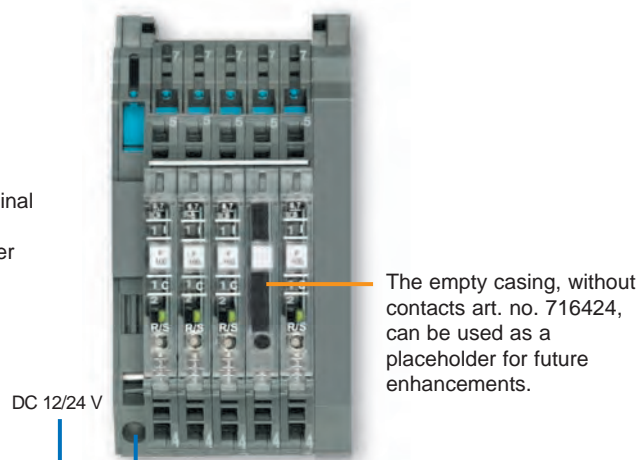

LOCC-Box / LOCC-Box-Net • Example Application

0V Collective Terminal

The 0V collective terminal 716420 enables the 0V return from the load to the 0V supply in the tightest space. The integrated sliding contact enables an insulation measurement when the contact is open.



Power Supply

e.g. art. no. 722805
24 V/20 A

Standard Application

with supply set, art. no. 716425

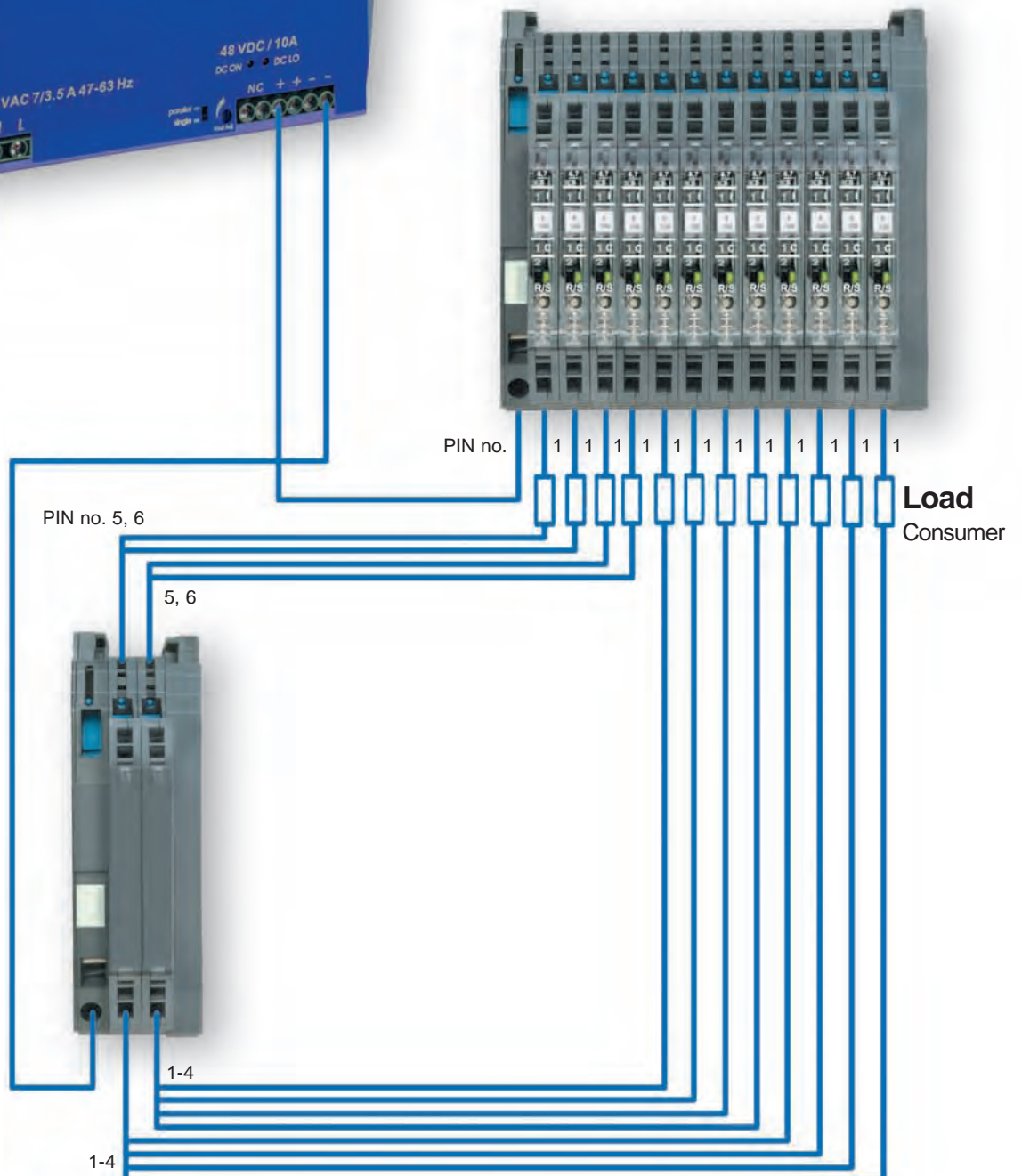

Construction of the 0V Collective terminal

with supply set
Art. no. 716425

Load monitoring - Microcompact LOCC Box

Electronic load monitoring up to DC 10 A
 Single-channel design, Adjustable current range: DC 1 A – 10 A
 Adjustable characteristics, fast, medium-speed, slow 1, -2, -3



Dimensions

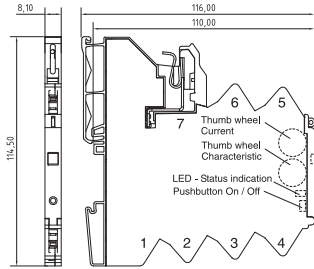

PIN assignment

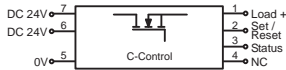

- 1: + Output
- 2: Control input (Set/Reset)
- 3: Status output
- 4: NC
- 5: 0V
- 6: + Supply (alternative)
- 7: + Supply

Description	Part-No.	Type	PU	
Spring terminal				
Nominal voltage	DC 12 / 24 V	716400	LOCC-Box-FB 7-6400	1
	DC 12 / 24 V	716401	LOCC-Box-FB 7-6401	1

Input	LOCC-Box-FB 7-6400	LOCC-Box-FB 7-6401
Nominal voltage	DC 12 / 24 V	DC 12 / 24 V
Operation voltage range	DC 10 V – 32 V	
Rated current	DC 10 A	
Supply current	DC 40 A over Cu-rails 10 x 3 mm	
Reverse voltage protection	internal electronics	
Termination	screwless disconnect slide	
Control input (Set / Reset)		
Signal level	DC 12 / 24 V (EN 61131)	
Fall time	Pulse with falling edge >100 ms, <800 ms	
Rise time	Pulse with falling edge > 1 s	
Connection	Spring terminal 0.25–2.5 mm ²	
Output		
Switching element	MosFet	
Output current	max. DC 10 A	
Voltage drop	<170 mV (10 A)	
Status Indication	LED green: Operating voltage present, no error LED red: Error in load circuit	
Switch-on capacity	10000 µF	
Current range	1 A – 10 A (adjustable via switch in 1 A steps)	
Characteristic	fast-acting, medium-slow, slow 1 (3), slow 2 (4), slow 3 (5)	

Signal output	LOCC-Box-FB 7-6400	LOCC-Box-FB 7-6401
Signal level	DC 12/24 V: Operating voltage present, no error; DC 0 V: error, output switched off	DC 12/24 V: Operating voltage present, no error; DC 0 V: error, output switched off and manual "OFF"
Switching element	Transistor, collector with pull-up resistance	

General	
Housing material	PA 6.6 (UL 94-V0; NFF I2, F2)
Field installation	rail TS 35 (EN 50022)
Protection class	IP 20
Installation position	Optional
Termination	Spring terminal 0.25–2.5 mm ²
Operation temperature range	-25 °C – 50 °C
Storage temperature range	-40 – 85 °C
Dimensions (w x h x d) in mm	8.1 x 114.5 x 116.0
Weight (kg/piece)	0.120
Approvals	cURus
Standards	EN 60950-1; EN 61131-1,2; EN 61000; EN 60947-4-1; EN 55022

Accessories	Colour	Article number	Description	PU
Feed in set (feed in terminal and end terminal), 10 mm ²		716425	LOCC Box ES 7-6425	1
Copper bus bar 1m		716426	LOCC Box CU 7-6426	1
Cu rail covering 1 m		716427	LOCC Box AD 7-6427	1
Jumper comb 8 pole, 6A	white	716428	LOCC Box BKW 7-6428	5
Jumper comb 8 pole, 6A	red	716429	LOCC Box BKR 7-6429	5
Jumper comb 8 pole, 6A	blue	716430	LOCC Box BKB 7-6430	5
Jumper comb 16-pole, 6 A	white	716438	LOCC Box BKW 7-6438	5
Jumper comb 16-pole, 6 A	red	716439	LOCC Box BKR 7-6439	5
Jumper comb 16-pole, 6 A	blue	716440	LOCC Box BKB 7-6440	5
Marker holder (200 pcs.)	white	716431	LOCC Box BZW 7-6431	1
Marker holder (200 pcs.)	red	716432	LOCC Box BZR 7-6432	1
Marker holder (200 pcs.)	blue	716433	LOCC Box BZB 7-6433	1
Marker holder (200 pcs.)	yellow	716434	LOCC Box BZG 7-6434	1

Signal output

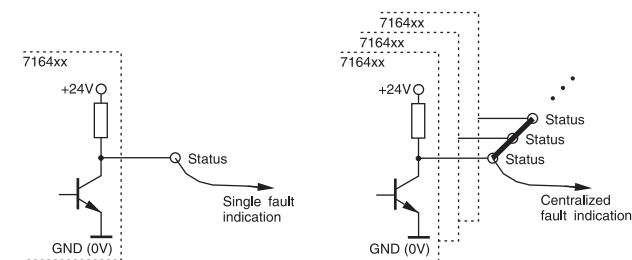

Load monitoring - Microcompact LOCC-Box-Net

Electronic load monitoring up to DC 10 A, with communication
 Single-channel design, programmable, Adjustable current range: DC 1 A – 10 A
 Adjustable characteristics, fast, medium-speed, slow 1, -2, -3



Dimensions

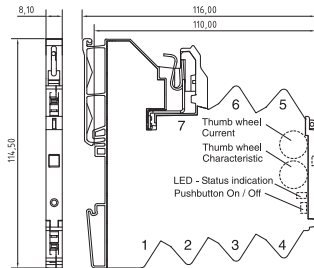

PIN assignment

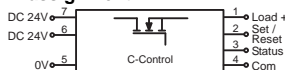

- 1: + Output
- 2: Control input (Set/Reset)
- 3: Status output
- 4: 1 Wire bus (Communication)
- 5: 0V
- 6: + Supply (alternative)
- 7: + Supply

Description	Part-No.	Type	PU
Spring terminal			
Nominal voltage	DC 12 / 24 V	716410	LOCC-Box-Net 7-6410
Input			
LOCC-Box-Net 7-6410			
Nominal voltage	DC 12 / 24 V		
Operation voltage range	DC 10 V – 32 V		
Rated current	DC 10 A		
Supply current	DC 40 A over Cu rail 10 x 3 mm		
Reverse voltage protection	internal electronics		
Termination	screwless disconnect slide		
Control input (Set / Reset)			
Signal level	DC 12 / 24 V (EN 61131)		
Fall time	Pulse with falling edge >100 ms, <800 ms		
Rise time	Pulse with falling edge > 1 s		
Connection	Spring terminal 0.25–2.5 mm ²		
Output			
Switching element	MosFet		
Output current	max. DC 10 A		
Voltage drop	<170 mV (10 A)		
Status Indication	LED green: Operating voltage present, no error LED red: Error in load circuit		
Switch-on capacity	10000 µF		
Current range	1 A – 10 A (adjustable via switch in 1 A steps)		
Characteristic	fast-acting, medium-slow, slow 1 (3), slow 2 (4), slow 3 (5)		
Signal output			
Signal level	DC 12/24 V: Operating voltage present, no error; DC 0 V: error, output switched off, programmable		
Switching element	Transistor, collector with pull-up resistance		
General			
Housing material	PA 6.6 (UL 94-V0; NFF I2, F2)		
Field installation	rail TS 35 (EN 50022)		
Protection class	IP 20		
Installation position	Optional		
Termination	Spring terminal 0.25–2.5 mm ²		
Operation temperature range	-25 °C – 50 °C		
Storage temperature range	-40 – 85 °C		
Dimensions (w x h x d) in mm	8.1 x 114.5 x 116.0		
Weight (kg/piece)	0.120		
Approvals	cURus		
Standards	EN 60950-1; EN 61131-1,2; EN 61000; EN 60947-4-1; EN 55022		

Accessories	Colour	Article number	Description	PU
Gateway on USB, CANopen, RS232		716459	LOCC Box GW 7-6459	1
Feed in set (feed in terminal and end terminal), 10 mm ²		716425	LOCC Box ES 7-6425	1
Copper bus bar 1m		716426	LOCC Box CU 7-6426	1
Cu rail covering 1 m		716427	LOCC Box AD 7-6427	1
Jumper comb 8 pole, 6A	white	716428	LOCC Box BKW 7-6428	5
Jumper comb 8 pole, 6A	red	716429	LOCC Box BKR 7-6429	5
Jumper comb 8 pole, 6A	blue	716430	LOCC Box BKB 7-6430	5
Jumper comb 16-pole, 6 A	white	716438	LOCC Box BKW 7-6438	5
Jumper comb 16-pole, 6 A	red	716439	LOCC Box BKR 7-6439	5
Jumper comb 16-pole, 6 A	blue	716440	LOCC Box BKB 7-6440	5
Marker holder (200 pcs.)	white	716431	LOCC Box BZW 7-6431	1
Marker holder (200 pcs.)	red	716432	LOCC Box BZR 7-6432	1
Marker holder (200 pcs.)	blue	716433	LOCC Box BZB 7-6433	1
Marker holder (200 pcs.)	yellow	716434	LOCC Box BZG 7-6434	1

Signal output

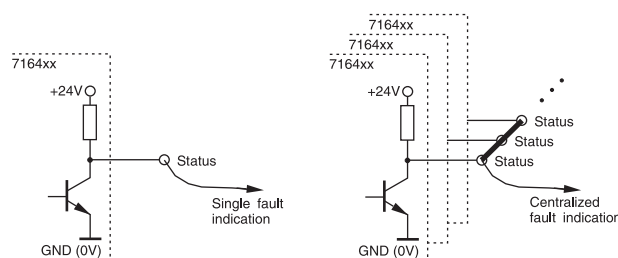

Load monitoring - Microcompact Gateway

Gateway für LOCC-Box-Net (716410)

Input: LOCCbus (LIN)

Output: USB, RS 232, CANopen



Dimensions

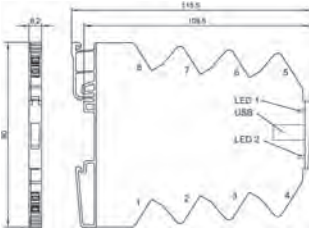

PIN assignment

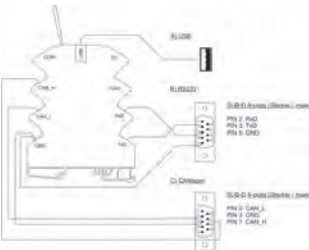

Description	Part-No.	Type	PU	
Spring terminal				
Nominal voltage	DC 12 / 24 V	716459	LOCC-Box-GW 7-6459	1
Input				
LOCC-Box-GW 7-6459				
Bus system	LOCCbus, basic LIN			
Access method	Single-Master - Multiple Slave			
Bus technology	Line			
Physical level	1-wire			
Participants	40, max. 254			
Bus length	max. 40 m			
Transfer rate	9600 Baud			
Data rate	8 Bit + fixed parity			
Transfer protocol	Modified multi-drop			
Output				
Bus system	USB 2.0 Full-Speed	RS232	CANopen	
Transfer rate	12 Mbit/s	600 – 11500 bit/s	10 – 1000 kbit/s	
General				
Nominal voltage	DC 12 / 24 V			
Operation voltage range	DC 10 V – 26.4 V			
Rated current	max. 50 mA			
Reverse voltage protection	Yes			
Status Indication	LED 1 green/red: USB, RS232, Firmware; LED 2 green/red: CANopen			
Insulation voltage	1.0 kV			
Housing material	PA 6.6 (UL 94-V0; NFF I2, F2)			
Field installation	rail TS 35 (EN 50022)			
Protection class	IP 20			
Installation postition	Optional			
Termination	Spring terminal : 0.14 - 2.5 mm ² (with AE 1.5 mm ²)			
Operation temperature range	-20 °C – 60 °C			
Storage temperature range	-40 – 85 °C			
Dimensions (w x h x d) in mm	6.2 x 90.0 x 115.0			
Weight (kg/piece)	0.060			
Approvals	CE			
Standards	EN 60950-1; EN 61131-1,2; EN 60898; EN 60947-4-1; EN 50081			
Accessories				
Tag holder 4x11 mm	Colour	Article number	Type	PU
Isolation plate	white	681313	BZT 0411	100
Labels for laser printer A4 unpunched		760809	TP 7-0809	5
Labels for laser printer 4.23 x 11 mm (Sheet with 1056 labels)		681031	LEB - A4	1
		681034	LEB 0411	1

LOCC-Box / LOCC-Box-Net • Characteristic Curves

All device variants incorporate the same characteristics

Extensible

Customer specific characteristics - parameterisable with LOCC-Box-Net

Switch position 1: Characteristic fast

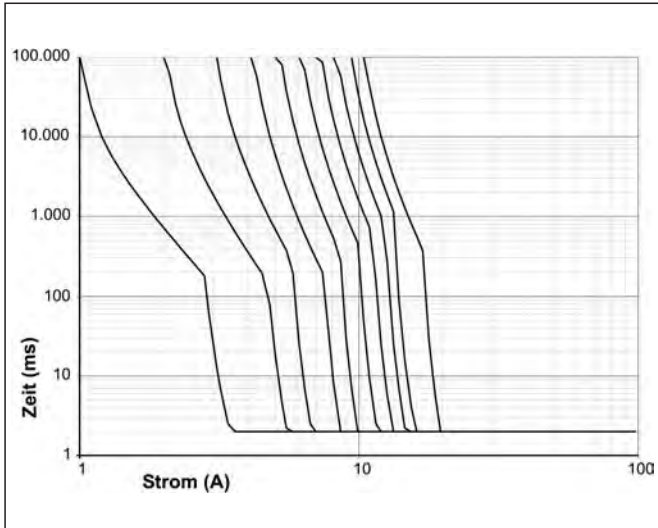

Switch position 2: Characteristic medium

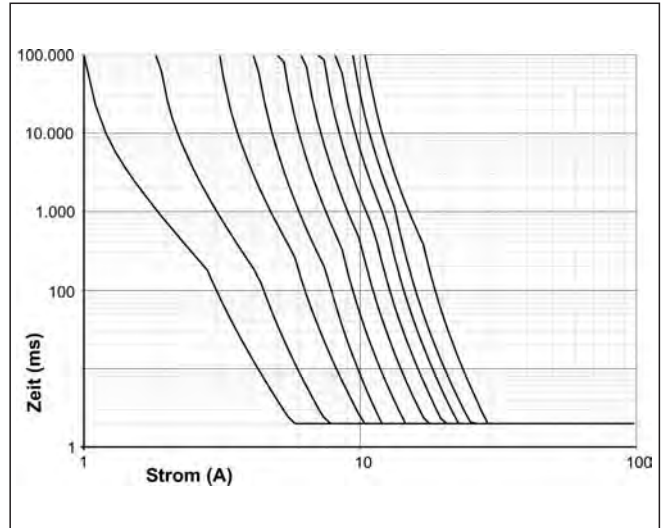

Switch position 3: Characteristic slow-1

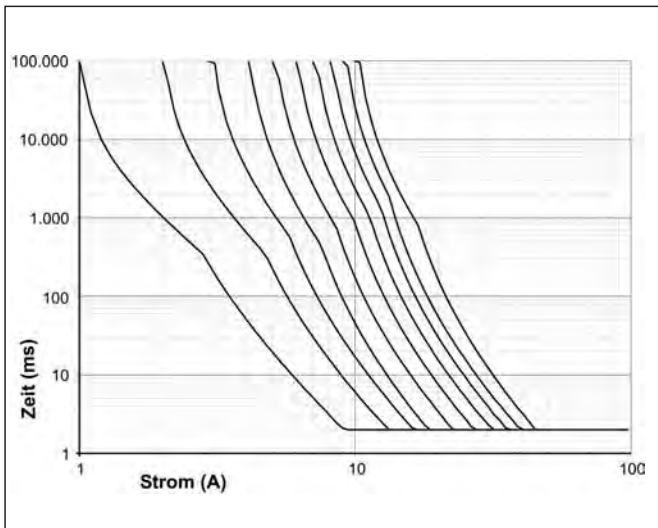

Switch position 4: Characteristic slow-2

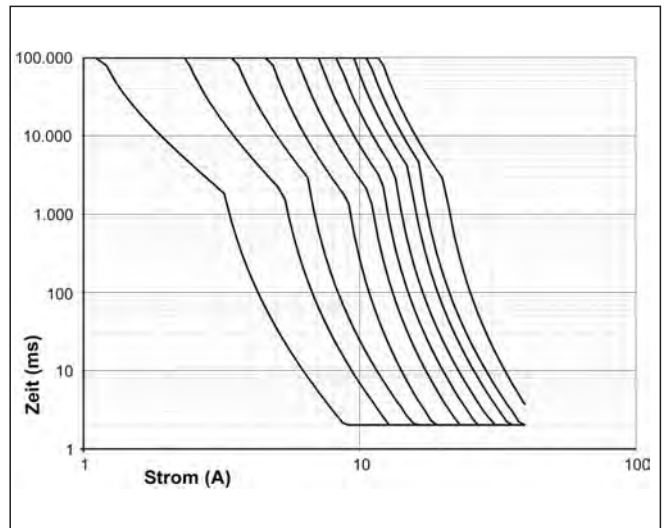

Switch position 5: Characteristic slow-3

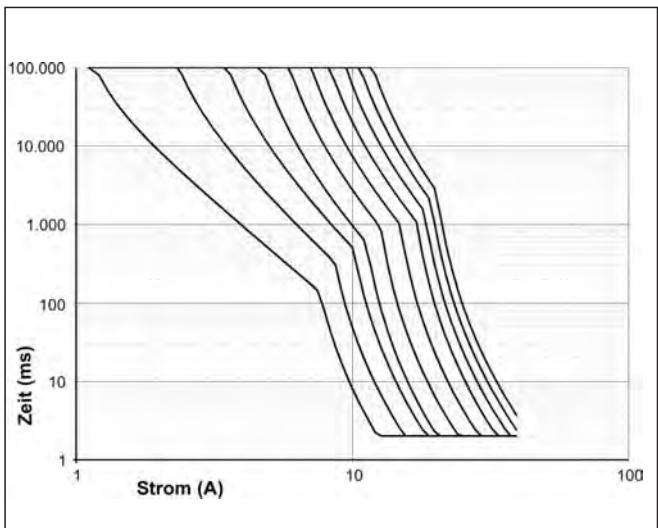

Load monitoring - Accessories

LOCC Box supply set consisting of supply terminal and end block maximum total current 40 A



Dimensions

Supply terminal

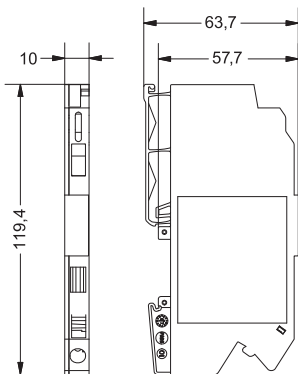

End block

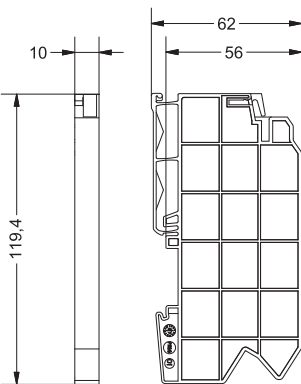

Description	Part-No.	Type	PU	
Nominal voltage	DC 12 / 24 V	716425	LOCC-Box-ES 7-6425	1
Input				
LOCC-Box-ES 7-6425				
Nominal voltage	DC 12 / 24 V			
Rated current	max. DC 40 A			
Reverse voltage protection	No			
Termination	Spring terminal : 0.33 – 10 mm ² (AWG 22–8) conductor connection cross section, single wire (solid): max. 10 mm ² conductor connection cross section, fine wire: max. 6 mm ² conductor connection cross section, fine wire with AEH: max. 6 mm ²			
Length of stripped insulation	12 mm			
Output				
Nominal voltage	DC 12 / 24 V			
Output current	max. DC 40 A			
Termination	screwless disconnect slit			
Copper bus bar	3 × 10mm			
General				
Housing material	PA 6.6 (UL 94-V0; NFF I2, F2)			
Field installation	rail TS 35 (EN 50022)			
Protection class	IP 20			
Installation position	Optional			
Operation temperature range	-25 °C – 60 °C			
Storage temperature range	-40 – 85 °C			
Dimensions (w × h × d) in mm	10.0 × 119.4 × 63.7			
Weight (kg/piece)	0.035			
Approvals	cURus			
Standards	–			

Load monitoring - Accessories

LOCC Box supply terminal Break out for copper bus bar for increased current maximum total current 40 A



Dimensions

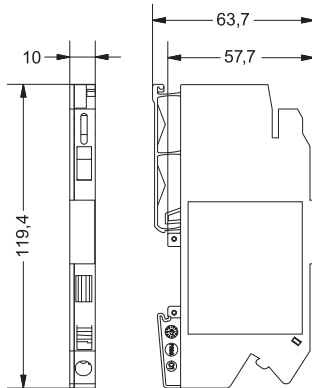

Use



Description	Part-No.	Type	PU	
Nominal voltage	DC 12 / 24 V	716421	LOCC-Box-EKL 7-6421	2
Input				
LOCC-Box-EKL 7-6421				
Nominal voltage	DC 12 / 24 V			
Rated current	max. DC 40 A			
Reverse voltage protection	No			
Termination	Spring terminal : 0.33 – 10 mm ² (AWG 22–8) conductor connection cross section, single wire (solid): max. 10 mm ² conductor connection cross section, fine wire: max. 6 mm ² conductor connection cross section, fine wire with AEH: max. 6 mm ²			
Length of stripped insulation	12 mm			
Output				
Nominal voltage	DC 12 / 24 V			
Output current	max. DC 40 A			
Termination	screwless disconnect slit			
Copper bus bar	3 x 10mm			
General				
Housing material	PA 6.6 (UL 94-V0; NFF I2, F2)			
Field installation	rail TS 35 (EN 50022)			
Protection class	IP 20			
Installation position	Optional			
Operation temperature range	-25 °C – 60 °C			
Storage temperature range	-40 – 85 °C			
Dimensions (w x h x d) in mm	10.0 x 199.4 x 63.7			
Weight (kg/piece)	0.035			
Approvals	cURus			
Standards	–			

Load monitoring - Accessories

0V Collective Terminal Single-channel design maximum total current 40 A



Dimensions

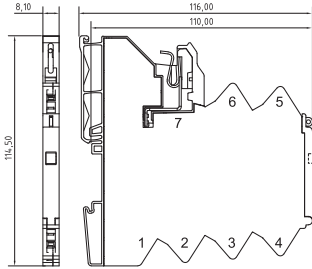

PIN assignment

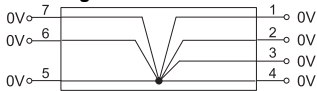

Description	Part-No.	Type	PU	
Nominal voltage	DC 12 / 24 V	716420	LOCC-Box-SK 7-6420	2
Input				
LOCC-Box-SK 7-6420				
Nominal voltage	DC 12 / 24 V			
Rated current	6x max. DC 10 A			
Reverse voltage protection	No			
Termination	Spring terminal: 0.25–2.5 mm ²			
Connection	1 – 6			
Output				
Output current	max. DC 40 A			
Voltage drop	–			
Termination	screwless disconnect slit			
Connection	7			
General				
Housing material	PA 6.6 (UL 94-V0; NFF I2, F2)			
Field installation	rail TS 35 (EN 50022)			
Protection class	IP 20			
Installation position	Optional			
Operation temperature range	-25 °C – 60 °C			
Storage temperature range	-40 – 85 °C			
Dimensions (w x h x d) in mm	8.1 x 114.5 x 116.0			
Weight (kg/piece)	0.700			
Approvals	–			
Standards	–			

Notes

Germany

Friedrich Lütze GmbH & Co. KG
Postfach 12 24 (PLZ 71366)
Bruckwiesenstrasse 17-19
D-71384 Weinstadt
Tel.: +49 (0)71 51 60 53-0
Fax: +49 (0)71 51 60 53-277(-288)
info@luetze.de

Lütze systems for highest industrial standards:

- ▶ Prepopulated
C-track systems
- ▶ Lütze-LSC-wiring
systems for all
standard control
panels
- ▶ Powerful module and
interface technology
- ▶ Reliable suppression
technology
- ▶ Efficient power
supplies
- ▶ Automation systems
for harsh environments

United Kingdom

LÜTZE Ltd.
Unit 3 Sandy Hill Park
Sandy Way, Amington
Tamworth, Staffs, B77 4DU
Tel.: +44 (0)18 27 31333-0
Fax: +44 (0)18 27 31333-2
sales.gb@lutze.co.uk

USA

LUTZE INC.
13330 South Ridge Drive
Charlotte, NC 28273
Tel.: +1 (704) 504-0222
Fax: +1 (704) 504 -0223
info@lutze.com

Österreich

LÜTZE Elektrotechnische
Erzeugnisse Ges.m.b.H.
Tel.: +43 (0)1 257 52 52-0
Fax: +43 (0)1 257 52 52-20
office@luetze.at

Schweiz

LÜTZE AG
Tel.: +41 (0)55 450 23 23
Fax: +41 (0)55 450 23 13
info@luetze.ch

France

LÜTZE S.A.
Tél.: +33 (0)1 34 18 77 00
Fax: +33 (0)1 34 18 18 44
lutze@lutze.fr

España

LUTZE, S.L.
Tel.: +34 93 285 7480
Fax: +34 93 285 7481
info@lutze.es

China

Lutze Control System (Shanghai) Ltd.
Tel. : +86 21 51007566 0
Fax : +86 21 51007565
sales@lutze.com.cn

www.luetze.com